

BS Range

CAT.00000



TEXTRON POWER TRANSMISSION

*Benzlers develops, manufactures
and supplies equipment for power
transmission and linear motion to
the world market.*

Benzlers

Benzlers is a leading manufacturer and supplier of power transmission equipment around the world. For over 50 years, our customers have gained the benefit of our experience and our products to satisfy their power transmission demands.

Quality products with high reliability and long durability are something that we feel should go without saying. We pride ourselves on short delivery times, high delivery reliability and the best possible service to our customers.

We have a well established market and service organisation with subsidiaries and agents in Europe and all over the world. This is important for internationally active companies who are searching for the right power transmission supplier.

This catalogue will help you select suitable products for your applications. Naturally, you are always welcome to contact our specialists for advice and solutions. We can also offer you CAD diskettes as support in your own work in CAD systems.

Welcome to Benzlers !

Contents

Technical information	5
Selection of worm gears and worm geared motors.....	6
Order procedure	10
Mounting positions.....	11

WORM GEARED MOTORS

Power ratings - Output speeds.....	12
Applications.....	25
Dimensions	26

WORM GEARS

Power ratings - Output speeds.....	40
Dimensions.....	48
Maximum input speed	57
Gear with Environmental classification	58
Combinationexamples	60
CAD	61
Mounting and maintenance instructions	62
Questionnaire.....	63

The programme

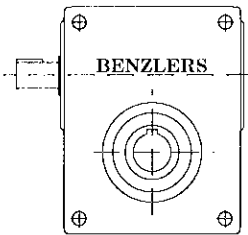
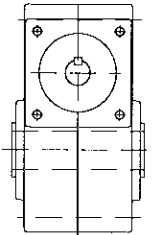
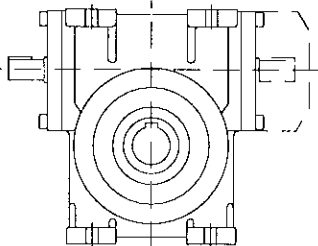
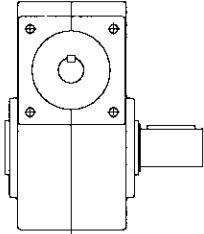
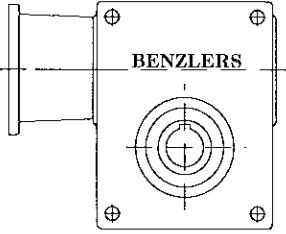
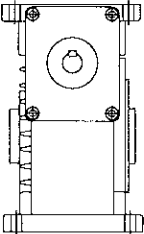
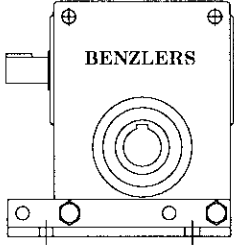
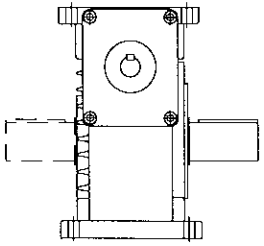
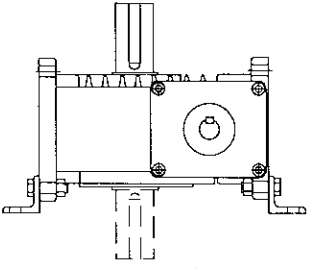
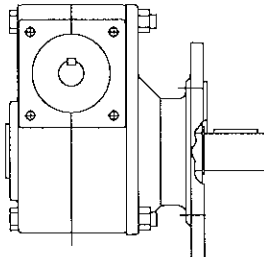
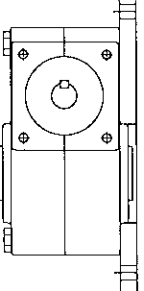
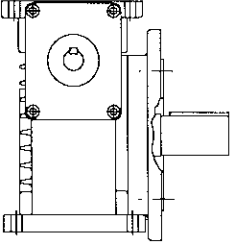
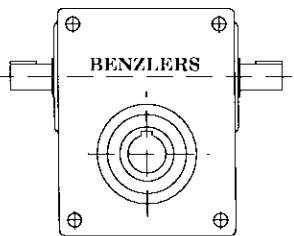
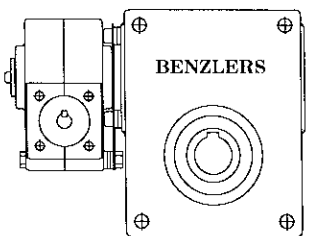
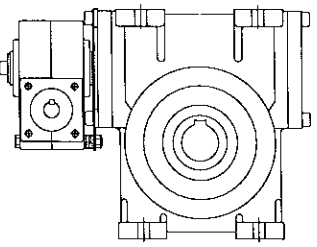
<p>BS 40-71</p>  <p>Single input shaft</p>	<p>BS 40-71</p>  <p>Hollow shaft</p>	<p>BS 88-112</p>  <p>Single input shaft</p>
<p>BS 40-71</p>  <p>Output shaft</p>	<p>BS 40-71</p>  <p>Motorflange</p>	<p>BS 88-112</p>  <p>Hollow shaft</p>
<p>BS 40-71</p>  <p>Feet</p>	<p>BS 88-112</p>  <p>Feet</p>	<p>BS 88-112</p>  <p>Horizontal</p>
<p>BS 40-71</p>  <p>Output flange</p>	<p>BS 40-71</p>  <p>Bolt the gear to a wall or foundation without feet or flange</p>	<p>BS 88-112</p>  <p>Output flange</p>
<p>BS 40-71</p>  <p>Double input shaft</p>	<p>BS 40-71</p>  <p>Double worm gears</p>	<p>BS 88-112</p>  <p>Double worm gears</p>

Technical information

Benzler worm gears BS 35-71 have a symmetrical gear-housing manufactured in aluminium. BS 88 and 112 have a gearhousing of cast-iron.

The worm wheel is made of centrifugal cast tinbronze and the worm screw is case-hardened and ground.

All motor connections are according to IEC-standard and for BS 40-112 with elastic coupling. This means the following advantages:

- The worm screw is mounted with two separate bearings and are not connected with the motor bearings. This means longer lifetime and a smoother drive..
- Soft start and stop with elastic coupling for size 40-112.
- No oil leakage in to the motor.
- Possibility to change motor without dismounting the gear.
- Any type of motor with IEC-flange can be used..

The worm geared motor is available for mounting on a base, flange or torque arm and can be installed in any position.

The gear can be combined with Benzlers' remaining range of helical and worm gears to provide very low output speeds. All data given in this catalogue applies to ABB standard motors and Benzlers brake motors.

Motorflanges

The motorflanges up to IEC-size 112 are made of aluminium and are available in B5 and B14, larger motorflanges are made of cast-iron and available in B5.

A finished bore shaft coupling is always delivered together with the motorflange.

Feet

The feet can be mounted without modification.

Output shaft

Single or double output shaft can be mounted into the hollow shaft. The output shafts are locked into position with keys and retaining rings. BS 88-112 has as standard execution, a single output shaft or a hollow shaft.

Output flange

An output flange can easily be mounted on to the gear. The BS 40-71 gear casing can also be mounted onto a wall or foundation and bolted through the 4 bolt holes in the gear casing.

Torque arm bracket

The hollow shaft gearboxes can be supplied with torque arm bracket and torque arm.

Fan

BS 88/112 have fan as an option.

Painting

BS35-71 is normally delivered without painting. BS 40-71 can be delivered according to environmental classification M2-M3, see page 58-59.

BS88-112 is normally delivered with standardpaint, which is an alkyd paint in Benzler blue colour (RAL 5015).

Selection of gears and gearmotors

Power and torque ratings for gears on page 40-47 apply to service factor 1.0. Service factor for geared motors can be found after the output speeds. Service factor 1.0 is valid for continuous operation 8 hours/day without shocks and with 10-200 starts per hour. The inertia of the driven machine is less than 20% of the electric motor. Occasional shock loads may not exceed 1.8 times the gear rating at service factor 1.0.

Determination of sizes

1. Determine the demand power or torque, P_e or T_{2b} ratio (i) or output speed (n_2).
2. Based on type of load/driven machine, operating hours/day and number of starts/hour, select service factor f_b (page 6-7).
3. Calculate $T_2 \geq T_{2b} \times f_b$.
4. Choose gear on page 40-47 according to following:
 $T_2 \geq T_{2b} \times f_b$ at required ratio (i) or speed (n_2).
 Note the efficiency.
 For example BS40 ratio 6,67:1, code A
 $\eta = 86\%$ at $n_1 = 1430$ rpm.
5. Calculate $P_1 = P_e \times f_b \times \frac{1}{\eta}$
 Choose a size larger motor $P_m \geq P_1$
 For example $P_1 \geq 0,42$ kW choose 0,55 kW.
6. Choose a worm gear motor on pages 12-24.
 For example BS40A with a motor size 80A4.
7. Check that occasional shock loads do not exceed 1.8 times the gear rating at service factor 1.0.
 $T_{2max} \geq T_2 \times 1,8$
8. Check that the thrust and overhung loads are not exceeded.
9. Check that maximum input speeds and thermal ratings are not exceeded.

10. For conditions other than above described, for instance extreme environments, high inertia systems or other, please contact your nearest Benzler office.

Formulas:

$$T_{2b} = \frac{P_e \times 9550}{n_2} \quad (\text{Nm})$$

$$T_2 \geq T_{2b} \times f_b \quad (\text{Nm})$$

$$P_1 = P_e \times f_b \times \frac{1}{\eta} \quad (\text{kW})$$

$$P_m \geq P_1 \quad (\text{kW})$$

$$T_{2max} \geq T_2 \times 1,8 \quad (\text{Nm})$$

$$J_{e, \text{red}} = J_e \times \left(\frac{n_2}{n_1} \right)^2 \quad (\text{kgm}^2)$$

T_2 = Output torque rating, Nm page 12-24, 40-47)

T_{2b} = Demand torque, Nm

T_{2max} = Occasional maximum torque, Nm

P_1 = Demand input power, kW

P_e = Demand power driven machine, kW

P_m = Motor power

n_1 = Input speed, rpm

n_2 = Output speed, rpm

f_b = Service factor

η = Efficiency of the gear

$J_{e, \text{red}}$ = Reduced inertia, kgm^2

J_e = Inertia driven machine, kgm^2

J_m = Inertia motor, kgm^2

Load classification	Description Moment of inertia	Example
I	$J_{e, \text{red}} \leq 0.2 \times J_m$ Machines with uniform load and no shocks	Uniform loaded conveyors and elevators. Centrifugal pumps and fans. Agitators and mixers for liquids and semiliquids without solid particles.
I a	$J_{e, \text{red}} \leq J_m$ Machines with small shocks and small variations in load	Larger conveyors. Reciprocating pumps with 3 or more cylinders. Agitators and mixers for media with high viscosity and/or solid particles.
II	$J_{e, \text{red}} \leq 3 \times J_m$ Machines with moderate shocks and variable load	Larger conveyors. Reciprocating pumps with 3 or more cylinders. Agitators and mixers for media with high viscosity and/or solid particles
III	$J_{e, \text{red}} \leq 10 \times J_m$ Machines with very heavy shocks and large masses to be accelerated	Heavy agitators and mixers. Reciprocating pumps with 1 or 2 cylinders. Crushers, mills and presses. Vibrators and shakers

Service factor f_b

Daily operations in hours	4 hours			8 hours			16 hours			24 hours		
Starts per hour	<10	10-200	>200	<10	10-200	>200	<10	10-200	>200	<10	10-200	>200
Load classification												
I	0.8	0.9	1.0	0.9	1.0	1.1	1.1	1.2	1.3	1.3	1.4	1.5
I _a	1.1	1.2	1.3	1.1	1.3	1.5	1.3	1.5	1.6	1.4	1.6	1.8
II	1.3	1.4	1.6	1.3	1.6	1.8	1.4	1.7	1.9	1.5	1.8	2.0
III	1.5	1.6	1.8	1.6	1.8	2.0	1.7	1.9	2.1	1.8	2.0	2.2

Ambient temperature factor f_t

For other ambient temperatures than 20° C, always multiply the thermal rating with the following factors.

°C Celsius	-40	-30	-20	-10	+/- 0	10	20	30	40	50
f_t	1.80	1.67	1.53	1.40	1.27	1.13	1.00	0.87	0.73	0.60

Fan factor f_f

If the gearbox has no fan and the motor is not directly flanged to the gearbox, multiply the thermal rating with the following factors.

Input speed n_1 (rpm)	10	100	300	750	1 000	1 500	3 000
f_f	1	0.95	0.74	0.63	0.65	0.69	0.77

Control points

The forces allowed on the gear shafts are determined by bearing life and strength on gear shafts and housing. Radial forces at no thrust loads. In the power ratings page 12-24 max. allowed radial force on output shaft is given for each output speed. The value is only valid if the force is applied at the centre of the output shaft. If the force is applied at another position the allowed radial force is given by the following:

Radial forces

Bearing life: $F_{r,x} = \frac{a}{(f+x)} F_{r2}$

Strength on shaft: $F_{r,x} = \frac{c}{x} F_{r2}$

Strength on gear housing: $F_{r,x} = \frac{d}{(g+x)} F_{r2max}$

$F_{r,x}$ = Max. radial force (N)
 F_{r2} = Radial force acc to power ratings (N).
 F_{r2max} = Upper limit, for radial force. Can not be exceeded (N)

a, d, f, g = Internal measures (mm)
 x = Distance to radial force (mm)
 c = Half shaft length (mm)

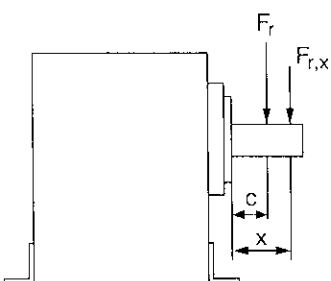

Type/Size	a	c	d	f	g	F_{r2max} (N)
BS 35	77.5	18	88.0	59.5	70.0	2 000
40	90.5	18	101.5	72.5	83.5	2 000
50	96.5	21	110.0	75.5	89.0	2 700
63	107.0	29	122.0	78.0	93.0	4 000
71	127.5	29	142.5	98.5	113.5	5 000
88	152.5	41	181.0	111.5	140.0	10 000
112	175.0	41	210.5	134.0	169.5	15 000

Overhung load

If a sprocket, gear wheel or pulley is mounted on a shaft, a load check must be made. The overhung load in middle of the shaft may not exceed values shown in tables below. For calculation of minimum permissible diameter the following formula should be used.

$$D_{\min} = \frac{2000 \times T_{2b} \times f_e \times f_b}{F_{r2}} \quad \text{mm}$$

T_{2b} = Torque required (Nm)

$$T_{2b} = \frac{P_e \times 9\,550}{n_2} \quad \text{Nm}$$

P_e = Power kW

n_2 = Output speed (rpm)

F_{r2} = Permissible overhung load (N)

f_b = Service factor (tables page 7)

f_e = 1.10 for sprockets

= 1.30 for gearwheels

= 1.50 for pulleys

D_{\min} = Minimum permissible diameter (mm)

Max overhung load in the middle of input shaft (N)

Gear	Ratio													
	Fr1	A	B	C	D	E	F	Fx	G	H	I	J	K	L
BS 40	180	135	100	95	80	70	-	50	45	45	40	30	-	-
50	215	190	155	115	100	80	70	65	55	55	40	-	-	-
63	385	305	255	210	165	155	125	115	100	100	75	45	-	-
71	400	350	285	240	180	150	-	115	100	100	60	45	-	-
88	925	635	470	405	335	305	-	235	200	200	190	145	100	65
112	1375	930	740	580	505	425	-	340	295	295	255	160	125	105

Max thrust load on output shaft (N)

Size	Ratio													
	A	B	C	D	E	F	Fx	G	H	I	J	K	L	M
BS 35	1500	1500	1500	1500	1500	1500	-	1500	-	-	-	-	-	-
40	2000	2000	2000	2000	2000	2000	-	2000	2000	2000	2000	2000	-	-
50	2500	2500	2500	2500	2500	2500	2500	2500	2500	2500	2500	-	-	-
63	3500	3500	3500	3500	3500	3500	3500	3500	3500	3500	3500	3500	-	-
71	4500	4500	4500	4500	4500	4500	-	4500	4500	4500	4500	4500	-	-
88	7800	10000	10000	10000	10000	10000	-	10000	10000	-	10000	10000	10000	10000
112	10400	14700	15000	15000	15000	15000	-	15000	15000	-	15000	15000	15000	15000

Reversing

Dynamic self locking means that a force applied on the output shaft of the gear can not continue to drive the gear when the motor has been stopped.

Dynamic self locking is only possible at very high ratios and low output speeds. None of the worm gears produced by BENZLERS is dynamic totally self locking.

Static self locking means that a force applied on the output shaft of the gear can not start a movement.

When driving loads with high inertia care must be taken to achieve a braking time long enough to prevent overload on the gear.

When a worm gear is used in an application with short braking time a worm gear that is "dynamically reversible" is normally the best selection.

Information regarding lead angle for BENZLERS worm gears are given on the following page.

Reversing as a function of the lead angle

γ	
$\geq 25^\circ$	Total reversing
$12^\circ - 25^\circ$	Statically reversible
$8^\circ - 12^\circ$	Variable static self locking Quick return in case of vibrations Dynamically reversible
$5^\circ - 8^\circ$	Statically self locking Return in case of vibrations Scant dynamic reversing
$3^\circ - 5^\circ$	Statically self locking Slow movement return in case of vibrations. Low dynamic reversing
$1^\circ - 3^\circ$	Statically self locking No return Low dynamic reversing

Benzlers Worm gear BS, Wormwheel and Wormscrew data

i = Ratio z = Starts of worm shaft η_s = Starting efficiency
 γ = Lead angle m = Module η = Running efficiency $n_1=1430$ rpm

	i	γ	z	m	η_s	η
BS 35	10 A	15.45	3	1.75	60	79
	15 B	10.45	2	1.75	51	74
	20 C	7.13	2	1.25	43	64
	25 D	5.71	1	2.0	37	60
	30 E	5.26	1	1.75	36	60
	40 F	3.58	1	1.25	27	48
	50 G	2.86	1	1.0	23	42
BS 40	6.67 A	15.52	3	2.5	60	86
	10 B	16.70	3	2	62	85
	15 C	11.31	2	2	53	79
	20 D	8.53	1	3	47	75
	24 E	7.13	1	2.5	43	71
	30 F	5.71	1	2	37	67
	40 G	4.02	1	1.45	30	59
	48 H	3.58	1	1.25	27	56
	60 I	2.86	1	1	23	49
	70 J	3.03	1	0.9	24	44
	84 K	2.53	1	0.75	21	36
BS 50	8 A	17.82	3	3	63	88
	10.5 B	15.07	2	3.5	60	87
	14 C	12.19	2	2.7	55	84
	21 D	7.67	1	3.5	44	77
	24 E	7.07	1	3	39	74
	32 F	5.71	1	2.4	37	71
	37 FX	4.40	1	2	32	66
	42 G	4.29	1	1.8	31	65
	54 H	3.34	1	1.4	26	59
	64 I	2.99	1	1.2	24	55
	80 J	2.86	1	1	23	49
BS 63	7.75 A	18.43	4	3	64	90
	11 B	17.82	3	3	63	88
	14 C	15.07	2	3.5	60	87
	18 D	10.20	2	2.7	51	83
	24.5 E	9.93	2	2.1	50	81
	29 F	7.67	1	3.5	44	77
	37 FX	4.47	1	2.5	32	70
	43 G	5.71	1	2.4	37	71
	51 H	4.76	1	2	33	67
	57 I	4.29	1	1.8	31	65
	73 J	3.34	1	1.4	26	59
	104 K	2.60	1	1	22	46

	i	γ	z	m	η_s	η	
BS 71	7.5 A	18.29	4	3.5	64	92	
	9.33 B	19.98	3	4	65	91	
	12 C	14.04	3	3	58	88	
	16 D	12.34	2	3.5	55	87	
	21 E	10.20	2	2.7	51	84	
	28 F	6.91	1	4	42	79	
	37 G	6.12	1	3	39	76	
	48 H	4.73	1	2.4	33	71	
	63 I	3.55	1	1.8	27	65	
	82 J	2.86	1	1.4	23	58	
	100 K	2.99	1	1.2	24	54	
	BS 88	7.25 A	21.80	4	4.5	67	94
		11.75 B	18.43	4	3	64	91
15.67 C		14.04	3	3	58	89	
19.50 D		9.93	2	3.5	50	87	
23.50 E		9.46	2	3	49	85	
29 F		5.71	1	4.5	38	80	
39 G		5.00	1	3.5	34	77	
47 H		4.76	1	3	33	75	
58 J		4.47	1	2.5	32	72	
71 K		3.37	1	2	26	67	
82 L		3.55	1	1.8	27	66	
106 M		2.86	1	1.4	23	57	
BS 112		7 A	22.48	4	6	68	94
	11.5 B	20.85	4	4	66	93	
	15.3 C	15.95	3	4	61	91	
	19.5 D	11.31	2	4.5	54	88	
	23 E	10.78	2	4	52	88	
	28 F	5.91	1	6	39	83	
	39 G	5.71	1	4.5	38	80	
	46 H	5.44	1	4	36	79	
	63 J	4.76	1	3	33	75	
	76 K	4.21	1	2.5	31	71	
	95 L	3.37	1	2	26	66	
	108 M	2.95	1	1.75	24	61	

Efficiency

The efficiency of the gear has to be considered when a worm gear or a worm geared motor is chosen. For intermittent duties it is necessary to increase the motor power to be able to compensate for the low efficiency during start.

Also consider that the highest efficiency is reached after

run-in period and under continuous duty.

All values given in the catalogue are only valid for a gear after running-in period under continuous duty with service factor 1.

If the gear is driven from the output shaft the back driving efficiency is calculated as follows:

$$\eta' = 2 \cdot \frac{1}{\eta}$$

Maximum input speed

	Size							
n_1, max	35	40	50	63	71	88	112i<60:1	112i>60:1
rpm	4500	6000	5500	5000	4500	4000	3000	3500

Questionnaire

To specify a drive precisely certain data are essential. The most important questions are listed in the table below. If you do not have the required data available in this form, we advise you to use a technical handbook or other suitable documentation. Should you have any question, please do not hesitate to contact us, Benzlers specialists will be pleased to assist you.

Load designation

Output power (kW): P_e	at n_{max}	at n_{min}	Motor			
			Enclosure IP			
Output speed (RPM):	n_{emox}	n_{emin}	Operating voltage	motor (V)	brake (V)	frequency (Hz)
Output torque (Nm): T_e	at n_{max}	at n_{min}	Brake torque (Nm)			
Overhung load (N): F_{r2e}	at output shaft	at input shaft	Ambient factors			
Axial thrust load (N): F_{a2e}	at output shaft	at input shaft	Ambient temperature (°C)			
(away + / towards -)			Load cycle / Duty cycle	S /	% ED	
Moment of inertia (kgm ²):	at output shaft	at input shaft	Starting frequency (1/h)			
Unit type and mounting position (see page 11)						

Gears and geared motors are described by a code consisting of 10 positions. Positions that aren't used are left empty. Additional information is written clearly.

Example of such information is:

- Output speed, Motor power
- Connecting voltage for motor and brake (if used)
- Type of motor at specific request
- All nonstandard executions that are not described in this catalogue.

Example on ordering text: (explanations, see page 11):

Gear					Motor				
1	2	3	4	5	6	7	8	9	10
BS	40	A	2,0H, M=115	-	4	80A4	-	180	B5
	214 rpm		0,37 kW			220-240/380-420V, 50 Hz			

Additional information:

1 Gear type

BS (Worm gear and worm geared motor)

2 Gear size

Standard sizes 35,40, 50, 63, 71, 88, 112, 50/40, 63/40, 71/40, 88/50, 112/63
Other combinations and sizes can be achieved.
Check with Benzlers.

3 Ratio code

A, B, C....FA, FB, FC (2 letters for double wormgears).

4 Mounting position

See picture *For execution - code 2 and 3 state flange size, for example M=115, see page 55.

5 Gear Accessories

VM = distance ring for different position of terminal box
EB = brake on gear
KEB = coupling/brake unit (specify type and voltage)
F = fan on gear (only BS88 and BS112)
DP = double input shaft

6 Input design

2 = free high speed shaft (no motor or flange for motor)
3 = prepared for motor (specify flange and shaft diametres or IEC-standard size)
4 = with motor

7 Motor

Acc. to IEC (71A, 71B)

8 Accessories for the motor

B = Brake
TB = Thermostat protection
Th = Thermistor protection
FS = Fitted with forced cooling
TG = Tachogenerator
PG = Encoder

9 Terminal box position

Positions acc picture

10 Motorflange

B14 = Small flange
B5 = Large flange

Motor flange B5

Position of terminal box

Motor sizes

	63	71	80	90	100	112	132	160	180
Gear									
BS 40	45*	45*	45*	45*					
50		0	0	0					
63		0	0	0					
71			45+	45+	45+	45+			
88			45	45	45	45	90		
112(i<60)					45	45	90	45	
112(i>60)				45	45	45	90		

BS35 is not available with B5-flange.

Mounting positions

Hollow shaft gear Execution - code 0	U	O	H-A	H-B
Feet and output shaft Execution - code 1	OV	OH	OD	
Only output shaft Execution - code 8	UV	UH	UD	
Only feet Execution - code 9	VV Endast BS 40-71	VH Endast BS 40-71	VD Endast BS 40-71	
Code 9 only for BS40-71	HUA	HN A	HD-A	
	HUB	HN-B	HD-B	
Output flange and shaft Execution - code 2* State M	BS 35-71 OH	BS 35-71 OV	BS 88-112 OH	
Output flange and hollow shaft Execution - code 3* State M	BS 35-71 OH	BS 35-71 OV	BS 88-112 OH	
Double gears (prestep gear is shown on picture)	P ₁	P ₂	P ₃	
	P ₄	P ₅	P ₆	
	P ₇	P ₈		
Execution - code 4				
Gear with hollow shaft, torque arm and connection Execution - code 5	O	V		

Position of terminal box

Standard position 0

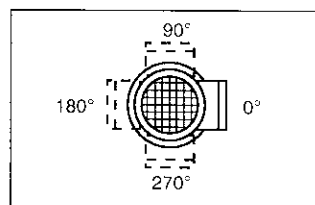

Standard position 45

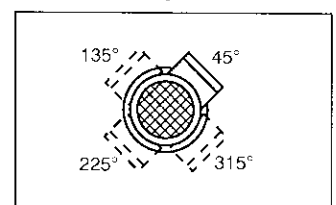

Motor flange B14

Position of terminal box

Motor sizes

	63	71	80	90	100	112	132	160	180
Gear									
BS 35	45	45							
40	45*	45*	45*	45*					
50		45*	45*	45*					
63		45*	45*	45*	45				
71			0+	0+	0+	0+			
88			0	0	0	0			
112				0	0	0			

* = Can be changed to 0 with distance ring, VM

+ = Distance ring to be mounted on gear

Worm geared motors

0.12 kW

Output speed n_2 rpm	Ratio i	Service factor f_{bp}	Output torque T_2 Nm	Permissible overhung load Fr_2 kN	Size	Weight kg	Dim. page			
0.69	1960.00 FJ	0.76	524	5.0	BS 71/40 63A-4	19	36-39			
0.81	1680.00 FI	0.86	463	5.0						
1.01	1344.00 FH	0.99	403	5.0						
1.21	1120.00 FG	1.13	354	5.0						
1.62	840.00 FF	1.34	299	5.0						
2.02	672.00 FE	1.57	255	5.0						
2.43	560.00 FD	1.77	226	5.0						
3.24	420.00 FC	2.20	182	5.0						
4.86	280.00 FB	3.00	133	5.0						
2.34	580.00 FD	0.76	234	4.0	BS 63/40 63A-4	16	36-39			
3.13	435.00 FC	0.96	189	4.0						
4.69	290.00 FB	1.33	138	4.0						
7.03	193.43 FA	1.96	95	4.0						
2.83	480.00 ED	1.30	113	2.7	BS 50/40 63A-4	14	36-39			
3.78	360.00 EC	0.99	146	2.7						
5.67	240.00 EB	1.33	108	2.7						
8.50	160.00 EA	1.93	75	2.7						
6.44	104.00 K	1.47	73	4.0	BS 63 71B-8	15	28-35			
9.18	73.00 J	3.10	58	4.0						
11.75	57.00 I	3.91	49	4.0						
8.94	104.00 K	2.09	50	4.0	BS 63 71-6	13	28-35			
8.38	80.00 J	1.24	62	2.7	BS 50 71B-8	13	28-35			
10.47	64.00 I	1.99	51	2.7						
11.63	80.00 J	1.94	39	2.7	BS 50 71-6	11	28-35			
14.53	64.00 I	3.03	33	2.7						
17.22	54.00 H	3.73	29	2.7						
7.98	84.00 K	0.75	48	2.0	BS 40 71B-8	11	28-35			
9.57	70.00 J	0.87	54	2.0						
11.17	60.00 I	1.20	46	2.0						
11.07	84.00 K	0.83	42	2.0	BS 40 71-6	9	28-35			
13.29	70.00 J	1.22	38	2.0						
15.50	60.00 I	1.66	32	2.0						
16.19	84.00 K	1.60	21	2.0	BS 40 63A-4	9	28-35			
19.43	70.00 J	2.36	19	2.0						
22.67	60.00 I	3.21	16	2.0						
28.33	48.00 H	4.15	14	2.0						
34.00	40.00 G	4.84	12	2.0						
45.33	30.00 F	5.97	10	2.0						
56.67	24.00 E	7.07	8	2.0						
68.00	20.00 D	8.18	7	2.0						
90.67	15.00 C	10.53	6	2.0						
136.00	10.00 B	14.84	4	2.0						
203.90	6.67 A	19.52	3	1.7						
13.00	50.00 G	.90	39	2.0				BS 35 71B-8	8.5	26-27
16.00	40.00 F	1.04	34	2.0						
22.00	30.00 E	1.26	29	2.0						
26.00	25.00 D	1.43	25	2.0						
33.00	20.00 C	1.62	21	2.0						
44.00	15.00 B	2.06	17	2.0						
67.00	10.00 A	2.94	12	2.0						
18.00	50.00 G	1.13	28	2.0	BS 35 71-6	7.0	26-27			
23.00	40.00 F	1.3	24	2.0						
31.00	30.00 E	1.54	20	2.0						
37.00	25.00 D	1.8	17	2.0						
46.00	20.00 C	2.13	15	2.0						
62.00	15.00 B	2.67	12	2.0						
93.00	10.00 A	3.78	8	1.9						
27.00	50.00 G	1.93	14	2.0				BS 35 63A-4	6.0	26-27
34.00	40.00 F	2.23	12	2.0						

Worm geared motors

0.12 kW

Output speed n_2 rpm	Ratio i	Service factor f_{bp}	Output torque T_2 Nm	Permissible overhung load Fr_2 kN	Size	Weight kg	Dim. page
45.00	30.00 E	2.70	10	2.0	BS 35 63A-4	6.0	26-27
54.00	25.00 D	3.16	8	2.0			
68.00	20.00 C	3.8	7	2.0			
90.00	15.00 B	4.78	5	2.0			
136.00	10.00 A	6.84	4	1.7			

Worm geared motors

0.18 kW

Output speed n_2 rpm	Ratio i	Service factor f_{bp}	Output torque T_2 Nm	Permissible overhung load Fr_2 kN	Size	Weight kg	Dim. page
1.22	1120.00 FG	0.76	529	5.0	BS 71/40 63B-4	19	36-39
1.63	840.00 FF	0.89	448	5.0			
2.04	672.00 FE	1.04	383	5.0			
2.45	560.00 FD	1.18	339	5.0			
3.26	420.00 FC	1.46	274	5.0			
4.89	280.00 FB	1.98	202	5.0			
7.34	186.76 FA	2.91	137	5.0			
4.72	290.00 FB	0.88	209	4.0	BS 63/40 63B-4	16	36-39
7.08	193.43 FA	1.29	144	4.0			
5.71	240.00 EB	0.89	163	2.7	BS 50/40 63B-4	14	36-39
8.56	160.00 EA	1.27	114	2.7			
6.60	106.00 M	2.35	123	10.0	BS 88 80A-8	51	28-35
7.00	100.00 K	1.40	118	5.0	BS 71 80A-8	21	28-35
8.54	82.00 J	2.15	100	5.0			
11.11	63.00 I	3.71	83	5.0	BS 63 80A-8	18	28-35
6.73	104.00 K	0.92	117	4.0			
9.59	73.00 J	1.94	92	4.0	BS 63 71A-6	14	28-35
8.85	104.00 K	1.19	88	4.0			
12.60	73.00 J	2.50	69	4.0			
16.14	57.00 I	3.30	58	4.0	BS 50 80A-8	16	28-35
8.75	80.00 J	0.80	96	2.7			
10.94	64.00 I	1.28	80	2.7			
12.96	54.00 H	1.67	72	2.7	BS 50 71A-6	12	28-35
11.50	80.00 J	1.10	68	2.7			
14.38	64.00 I	1.72	58	2.7			
17.04	54.00 H	2.12	51	2.7			
21.90	42.00 G	2.53	43	2.7			
24.86	37.00 Fx	2.76	38	2.7			
11.67	60.00 I	0.78	72	2.0	BS 40 80A-8	14	28-35
15.33	60.00 I	0.99	54	2.0	BS 40 71A-6	10	28-35
19.17	48.00 H	1.37	48	2.0			
16.31	84.00 K	0.81	41	2.0	BS 40 63B-4	9	28-35
19.57	70.00 J	1.19	37	2.0			
22.83	60.00 I	1.62	32	2.0			
28.54	48.00 H	2.09	28	2.0			
34.25	40.00 G	2.44	24	2.0			
45.67	30.00 F	3.01	20	2.0			
57.08	24.00 E	3.56	16	2.0			
68.50	20.00 D	4.12	14	2.0			
91.33	15.00 C	5.31	11	2.0			
137.00	10.00 B	7.48	8	2.0			

Worm geared motors

0.18 kW

Output speed n_2 rpm	Ratio i	Service factor f_{bp}	Output torque T_2 Nm	Permissible overhung load Fr_2 kN	Size	Weight kg	Dim. page
205.40	6.67 A	9.84	5	1.7	BS 40 63B-4	9	28-35
184.00	15.00 C	31.13	1	1.9	BS 40 63K-2	9	28-35
276.00	10.00 B	44.16	1	1.6			
413.79	6.67 A	56.96	1	1.3			
26	25 D	.87	40	2.0	BS 35 71C-8	9.5	26-27
33	20 C	.98	35	2.0			
44	15 B	1.25	28	2.0			
66	10 A	1.79	20	2.0			
30	30 E	.92	34	2.0	BS 35 71A-6	7.5	26-27
37	25 D	1.07	29	2.0			
46	20 C	1.27	24	2.0			
61	15 B	1.59	19	2.0			
92	10 A	2.25	14	1.9			
27	50 G	.97	27	2.0	BS 35 63B-4	6.5	26-27
34	40 F	1.13	23	2.0			
45	30 E	1.36	19	2.0			
54	25 D	1.59	16	2.0			
68	20 C	1.92	14	2.0			
91	15 B	2.41	11	2.0			
137	10 A	3.45	8	1.7			

Worm geared motors

0.25 kW

Output speed n_2 rpm	Ratio i	Service factor f_{bp}	Output torque T_2 Nm	Permissible overhung load Fr_2 kN	Size	Weight kg	Dim. page			
0.48	2912.00 FK	0.93	1433	15.0	BS 112/63 71 A-4	71	36-39			
0.68	2044.00 FJ	1.19	1178	15.0						
0.88	1596.00 FI	1.40	1000	15.0						
0.98	1428.00 FH	1.49	942	15.0						
1.16	1204.00 FG	1.64	853	15.0						
1.35	1036.00 FFx	1.91	733	15.0						
1.72	812.00 FF	2.18	641	15.0						
2.04	686.00 FE	2.43	575	15.0						
2.78	504.00 FD	3.14	445	15.0						
3.57	392.00 FC	3.72	377	15.0						
0.75	1856.00 FI	0.82	976	10.0				BS 88/50 71A-4	52	36-39
0.89	1566.00 FH	0.91	876	10.0						
1.15	1218.00 FG	1.05	763	10.0						
1.30	1073.00 FFx	1.13	707	10.0						
1.51	928.00 FF	1.24	643	10.0						
2.01	696.00 FE	1.55	516	10.0						
2.30	609.00 FD	1.66	481	10.0						
3.45	406.00 FC	2.22	360	10.0						
4.60	304.50 FB	2.77	289	10.0						
6.03	232.00 FA	3.48	230	10.0						
2.08	672.00 FE	0.77	522	5.0	BS 71/40 71A-4	20	36-39			
2.50	560.00 FD	0.86	463	5.0						
3.33	420.00 FC	1.07	374	5.0						
5.00	280.00 FB	1.45	276	5.0						
7.50	186.76 FA	2.11	190	5.0						
7.24	193.43 FA	0.94	198	4.0	BS 63/40 71A-4	17	36-39			
8.75	160.08 EA	0.92	156	2.7	BS 50/40 71 A-4	15	36-39			
8.85	104.00 K	0.79	132	4.0	BS 63 71 B-6	15	28-35			

Worm geared motors

0.25 kW

Output speed n_2 rpm	Ratio i	Service factor f_{bp}	Output torque T_2 Nm	Permissible overhung load Fr_2 kN	Size	Weight kg	Dim. page			
12.60	73.00 J	1.67	104	4.0	BS 63 71 B-6	15	28-35			
16.14	57.00 I	2.21	87	4.0						
18.04	51.00 H	2.29	80	4.0						
21.40	43.00 G	2.32	72	4.0						
13.46	104.00 K	1.30	77	4.0	BS 63 71A-4	14	28-35			
19.18	73.00 J	2.69	60	4.0						
24.56	57.00 I	3.18	50	4.0						
27.45	51.00 H	3.46	46	4.0						
14.38	64.00 I	1.15	87	2.7	BS 50 71B 6	13	28-35			
17.04	54.00 H	1.42	77	2.7						
17.50	80.00 J	1.07	66	2.7	BS 50 71A-4	12	28-35			
21.88	64.00 I	1.70	55	2.7						
25.93	54.00 H	1.86	48	2.7						
33.33	42.00 G	2.23	40	2.7						
37.84	37.00 Fx	2.45	36	2.7						
43.75	32.00 F	2.75	33	2.7						
19.17	48.00 H	0.94	70	2.0				BS 40 71B 6	11	28-35
23.00	40.00 G	1.12	61	2.0						
20.00	70.00 J	0.77	57	2.0	BS 40 71A-4	10	28-35			
23.33	60.00 I	1.04	50	2.0						
29.17	48.00 H	1.35	43	2.0						
35.00	40.00 G	1.57	37	2.0						
46.67	30.00 F	1.94	30	2.0						
58.33	24.00 E	2.30	25	2.0						
70.00	20.00 D	2.66	22	2.0						
93.33	15.00 C	3.43	17	2.0						
140.00	10.00 B	4.83	12	2.0						
209.90	6.67 A	6.35	8	1.7						
183.33	15.00 C	9.36	5	1.9				BS 40 63B-2	9	28-35
275.00	10.00 B	13.28	3	1.6						
412.29	6.67 A	17.13	2	1.3						
46.00	20.00 C	.87	35	2.0	BS 35 71B-6	8.5	26-27			
61.00	15.00 B	1.09	29	2.0						
92.00	10.00 A	1.54	20	1.9						
46.00	30.00 E	.88	30	2.0	BS 35 71A-4	7.5	26-27			
56.00	25.00 D	1.03	25	2.0						
70.00	20.00 C	1.24	21	2.0						
93.00	15.00 B	1.55	17	2.0						
140.00	10.00 A	2.23	12	1.7						
275.00	10.00 A	5.93	3	1.3						

Worm geared motors

0.37 kW

Output speed n_2 rpm	Ratio i	Service factor f_{bp}	Output torque T_2 Nm	Permissible overhung load Fr_2 kN	Size	Weight kg	Dim. page
0.68	2044.00 FJ	0.80	1747	15.0	BS 112/63 71B-4	72	36-39
0.88	1596.00 FI	0.94	1483	15.0			
0.98	1428.00 FH	1.00	1398	15.0			
1.16	1204.00 FG	1.10	1267	15.0			
1.35	1036.00 FFx	1.29	1089	15.0			
1.72	812.00 FF	1.47	954	15.0			
2.04	686.00 FE	1.64	856	15.0			
2.78	504.00 FD	2.11	664	15.0			

Worm geared motors

0.37 kW

Output speed n_2 rpm	Ratio i	Service factor f_{bp}	Output torque T_2 Nm	Permissible overhung load Fr_2 kN	Size	Weight kg	Dim. page			
2.78	504.00 FD	2.11	664	15.0	BS 112/63 71B-4	72	36-39			
3.57	392.00 FC	2.49	563	15.0						
4.55	308.00 FB	3.08	455	15.0						
1.30	1073.00 FFx	0.76	1050	10.0	BS 88/50 71B-4	53	36-39			
1.51	928.00 FF	0.84	954	10.0						
2.01	696.00 FE	1.04	766	10.0						
2.30	609.00 FD	1.12	716	10.0						
3.45	406.00 FC	1.49	536	10.0						
4.60	304.50 FB	1.86	431	10.0						
6.03	232.00 FA	2.33	344	10.0						
5.00	280.00 FB	0.97	411	5.0				BS 71/40 71B-4	21	36-39
7.50	186.76 FA	1.41	284	5.0						
6.48	108.00 M	1.92	294	15.0	BS 112 90S-8	71	28-35			
7.37	95.00 L	2.53	271	15.0						
6.60	106.00 M	1.00	288	10.0	BS 88 90S 8	54	28-35			
8.54	82.00 L	1.74	241	10.0						
9.86	71.00 K	2.38	212	10.0						
8.68	106.00 M	1.30	216	10.0	BS 88 80A-6	50	28-35			
11.22	82.00 L	2.27	180	10.0						
12.96	71.00 K	3.15	156	10.0						
8.54	82.00 J	0.95	228	5.0	BS 71 90S-8	24	28-35			
9.20	100.00 K	0.78	207	5.0	BS 71 80A-6	20	28-35			
11.22	82.00 J	1.22	172	5.0						
14.60	63.00 I	1.97	143	5.0						
19.17	48.00 H	2.37	118	5.0						
9.59	73.00 J	0.85	210	4.0						
12.60	73.00 J	1.07	163	4.0	BS 63 80A-6	17	28-35			
16.14	57.00 I	1.41	137	4.0						
18.04	51.00 H	1.46	126	4.0						
13.46	104.00 K	0.77	130	4.0	BS 63 71B-4	15	28-35			
19.18	73.00 J	1.60	101	4.0						
24.56	57.00 I	1.88	85	4.0						
27.45	51.00 H	2.05	78	4.0						
32.56	43.00 G	2.34	68	4.0						
37.84	37.00 Fx	2.56	57	4.0						
48.28	29.00 F	3.18	49	4.0						
12.96	54.00 H	0.76	159	2.7				BS 50 90S-8	19	28-35
17.04	54.00 H	0.90	121	2.7				BS 50 80A 6	15	28-35
21.88	64.00 I	1.04	89	2.7	BS 50 71B-4	13	28-35			
25.93	54.00 H	1.14	79	2.7						
33.33	42.00 G	1.37	66	2.7						
37.84	37.00 Fx	1.50	59	2.7						
43.75	32.00 F	1.68	53	2.7						
58.33	24.00 E	2.07	41	2.7						
66.67	21.00 D	2.33	37	2.7						
100.00	14.00 C	3.34	26	2.7						
29.17	48.00 H	0.83	70	2.0				BS 40 71B-4	11	28-35
35.00	40.00 G	0.97	60	2.0						
46.67	30.00 F	1.19	50	2.0						
58.33	24.00 E	1.41	41	2.0						
89.00	10.00 A	.96	32	1.9	BS 35 71C-6	9.5	26-27			
93.00	15.00 B	.95	27	2.0	BS 35 71B-4	8.5	26-27			
140.00	10.00 A	1.37	19	1.7						
282.00	10.00 A	2.77	7	1.3	BS 35 71A-2	7.5	26-27			

Worm geared motors

0.55 kW

Output speed n_2 rpm	Ratio i	Service factor f_{bp}	Output torque T_2 Nm	Permissible overhung load Fr_2 kN	Size	Weight kg	Dim. page			
1.36	1036.00 FFx	0.87	1612	15.0	BS 112/63 80A-4	74	36-39			
1.74	812.00 FF	0.99	1412	15.0						
2.06	686.00 FE	1.10	1268	15.0						
2.80	504.00 FD	1.42	985	15.0						
3.60	392.00 FC	1.67	836	15.0						
4.58	308.00 FB	2.07	677	15.0						
6.50	217.00 FA	2.73	514	15.0						
2.32	609.00 FD	0.75	1060	10.0	BS 88/50 80A-4	55	36-39			
3.47	406.00 FC	1.01	795	10.0						
4.63	304.50 FB	1.25	639	10.0						
6.08	232.00 FA	1.57	511	10.0						
7.55	186.76 FA	0.94	424	5.0	BS 71/40 80A-4	23	36-39			
6.48	108.00 M	1.22	461	15.0	BS 112 90L-8	74	28-35			
7.37	95.00 L	1.61	425	15.0						
9.21	76.00 K	2.35	366	15.0						
8.54	82.00 L	1.13	372	10.0	BS 88 90L-8	57	28-35			
9.86	71.00 K	1.54	327	10.0						
8.68	106.00 M	0.82	341	10.0	BS 88 80B-6	51	28-35			
11.22	82.00 L	1.44	285	10.0						
12.96	71.00 K	2.00	246	10.0						
15.86	58.00 J	2.59	216	10.0						
13.30	106.00 M	1.22	221	10.0	BS 88 80A-4	50	28-35			
17.20	82.00 L	2.12	184	10.0						
19.86	71.00 K	2.74	159	10.0						
24.31	58.00 J	3.51	139	10.0						
11.11	63.00 I	1.07	290	5.0	BS 71 90L-8	27	28-35			
11.22	82.00 J	0.78	269	5.0	BS 71 80B-6	21	28-35			
14.60	63.00 I	1.26	223	5.0						
19.17	48.00 H	1.52	185	5.0	BS 71 80A-4	20	28-35			
17.20	82.00 J	1.14	177	5.0						
22.38	63.00 I	1.60	146	5.0						
29.38	48.00 H	1.97	119	5.0						
38.11	37.00 G	2.47	96	5.0						
50.36	28.00 F	2.97	76	5.0						
67.14	21.00 E	3.87	59	4.6						
16.14	57.00 I	0.91	212	4.0				BS 63 80B-6	18	28-35
18.04	51.00 H	0.94	195	4.0						
21.40	43.00 G	0.96	173	4.0						
19.32	73.00 J	1.00	162	4.0	BS 63 80A-4	17	28-35			
24.74	57.00 I	1.18	136	4.0						
27.65	51.00 H	1.28	125	4.0						
32.79	43.00 G	1.46	109	4.0						
38.11	37.00 Fx	1.60	92	4.0						
48.62	29.00 F	1.99	78	4.0						
57.55	24.50 E	2.33	69	4.0						
78.33	18.00 D	2.92	51	3.9						
33.57	42.00 G	0.87	103	2.7				BS 50 80A-4	15	28-35
38.11	37.00 Fx	0.96	92	2.7						
44.06	32.00 F	1.07	84	2.7						
58.75	24.00 E	1.32	65	2.7						
67.14	21.00 D	1.49	59	2.7						
100.71	14.00 C	2.13	41	2.7						
134.29	10.50 B	2.74	32	2.7						
176.25	8.00 A	3.40	24	2.4						
201.43	14.00 C	3.82	17	2.5	BS 50 71B-2	13	28-35			
58.75	24.00 E	0.90	65	2.0	BS 40 80A-4	13	28-35			

Worm geared motors

0.55 kW

Output speed n_2 rpm	Ratio i	Service factor f_{bp}	Output torque T_2 Nm	Permissible overhung load Fr_2 kN	Size	Weight kg	Dim. page
70.50	20.00 D	1.04	56	2.0	BS 40 80A-4	13	28-35
94.00	15.00 C	1.34	43	2.0			
141.00	10.00 B	1.89	30	2.0			
211.39	6.67 A	2.48	20	1.7			
188.00	15.00 C	2.40	18	1.9	BS 40 71B-2	11	28-35
282.00	10.00 B	3.41	13	1.6			
422.79	6.67 A	4.40	8	1.3			
138.00	10.00 A	0.85	31	1.7	BS 35 71C-4	9.5	26-27
282.00	10.00 A	1.52	12	1.3	BS 35 71B-2	8.5	26-27

Worm geared motors

0.75 kW

Output speed n_2 rpm	Ratio i	Service factor f_{bp}	Output torque T_2 Nm	Permissible overhung load Fr_2 kN	Size	Weight kg	Dim. page
2.06	686.00 FE	0.81	1733	15.0	BS 112/63 80B-4	75	36-39
2.80	504.00 FD	1.04	1347	15.0			
3.60	392.00 FC	1.22	1144	15.0			
4.58	308.00 FB	1.51	928	15.0			
6.50	217.00 FA	1.99	705	15.0			
4.63	304.50 FB	0.92	874	10.0	BS 88/50 80B-4	56	36-39
6.08	232.00 FA	1.14	699	10.0			
6.48	108.00 M	0.87	647	15.0	BS 112 100LA 8	80	28-35
7.37	95.00 L	1.15	596	15.0			
9.21	76.00 K	1.67	513	15.0			
8.52	108.00 M	1.10	497	15.0	BS 112 90S-6	71	28-35
9.68	95.00 L	1.46	457	15.0			
12.11	76.00 K	2.19	393	15.0			
14.60	63.00 J	2.96	339	15.0			
8.54	82.00 L	0.81	518	10.0	BS 88 100LA-8	62	28-35
9.86	71.00 K	1.11	455	10.0			
11.22	82.00 L	1.02	400	10.0	BS 88 90S-6	54	28-35
12.96	71.00 K	1.42	347	10.0			
15.66	58.00 J	1.84	304	10.0			
13.30	106.00 M	0.85	318	10.0	BS 88 80B-4	51	28-35
17.20	82.00 L	1.48	264	10.0			
19.86	71.00 K	1.91	229	10.0			
24.31	58.00 J	2.44	200	10.0			
30.00	47.00 H	3.06	166	10.0			
36.15	39.00 G	3.76	140	10.0			
14.58	48.00 H	0.91	339	5.0			
19.17	48.00 H	1.09	259	5.0	BS 71 90S-6	24	28-35
17.20	82.00 J	0.80	251	5.0	BS 71 80B-4	21	28-35
22.38	63.00 I	1.13	207	5.0			
29.38	48.00 H	1.38	169	5.0			
38.11	37.00 G	1.74	137	5.0			
50.36	28.00 F	2.09	108	5.0			
67.14	21.00 E	2.72	85	4.6			
88.13	16.00 D	3.40	66	4.0			

Worm geared motors

0.75 kW

Output speed n_2 rpm	Ratio i	Service factor f_{bp}	Output torque T_2 Nm	Permissible overhung load F_2 kN	Size	Weight kg	Dim. page
24.74	57.00 I	0.83	193	4.0	BS 63 80B-4	18	28-35
27.65	51.00 H	0.90	177	4.0			
32.79	43.00 G	1.03	155	4.0			
38.11	37.00 Fx	1.13	130	4.0			
48.62	29.00 F	1.40	111	4.0			
57.55	24.50 E	1.64	97	4.0			
78.33	18.00 D	2.06	72	3.9			
100.71	14.00 C	2.64	58	3.4			
128.18	11.00 B	3.22	46	3.0			
158.33	18.00 D	3.59	31	3.1	BS 63 80A-2	17	28-35
44.06	32.00 F	0.76	118	2.7	BS 50 80B-4	16	28-35
58.75	24.00 E	0.94	91	2.7			
67.14	21.00 D	1.06	82	2.7			
100.71	14.00 C	1.51	58	2.7			
134.29	10.50 B	1.95	45	2.7			
176.25	8.00 A	2.41	34	2.4			
203.57	14.00 C	2.58	26	2.5	BS 50 80A-2	15	28-35
271.43	10.50 B	3.31	20	2.2			
94.00	15.00 C	0.95	61	2.0	BS 40 80B-4	14	28-35
141.00	10.00 B	1.34	43	2.0			
211.39	6.67 A	1.76	28	1.7			
190.00	15.00 C	1.62	27	1.9	BS 40 80A-2	13	28-35
285.00	10.00 B	2.30	19	1.6			
427.29	6.67 A	2.97	12	1.3			
282.00	10.00 A	1.02	19	1.3	BS 35 71C-2	9.5	26-27

Worm geared motors

1.1 kW

Output speed n_2 rpm	Ratio i	Service factor f_{bp}	Output torque T_2 Nm	Permissible overhung load F_{r2} kN	Size	Weight kg	Dim. page
3.60 4.58 6.50	392.00 FC 308.00 FB 217.00 FA	0.83 1.03 1.35	1683 1366 1039	15.0 15.0 15.0	BS 112/63 90S-4	78	36-39
7.37 9.21	95.00 L 76.00 K	0.76 1.11	895 770	15.0 15.0	BS 112 100LB-8	83	28-35
9.68 12.11	95.00 L 76.00 K	0.96 1.45	692 594	15.0 15.0	BS 112 90L-6	74	28-35
14.60	63.00 J	1.96	513	15.0	BS 112 90L-6	74	28-35
13.06 14.84 18.55 22.38	108.00 M 95.00 L 76.00 K 63.00 J	1.06 1.40 2.17 2.65	495 454 383 330	15.0 15.0 15.0 15.0	BS 112 90S-4	71	28-35
12.96 15.86	71.00 K 58.00 J	0.94 1.22	522 458	10.0 10.0	BS 88 90L-6	57	28-35
17.20 19.86 24.31 30.00 36.15 48.62 60.00	82.00 L 71.00 K 58.00 J 47.00 H 39.00 G 29.00 F 23.50 E	0.97 1.25 1.60 2.00 2.46 3.18 3.39	404 350 306 254 213 165 141	10.0 10.0 10.0 10.0 10.0 9.7 9.0	BS 88 90S-4	54	28-35
29.38 38.11 50.36 67.14 88.13 117.50 151.13	48.00 H 37.00 G 28.00 F 21.00 E 16.00 D 12.00 C 9.33 B	0.91 1.14 1.38 1.79 2.24 2.84 3.62	257 208 163 128 100 76 60	5.0 5.0 5.0 4.6 4.0 3.5 3.0	BS 71 90S 4	24	28-35
48.62 57.55 78.33 100.71 128.18 181.94	29.00 F 24.50 E 18.00 D 14.00 C 11.00 B 7.75 A	0.92 1.08 1.35 1.74 2.12 2.68	169 148 110 88 70 50	4.0 4.0 3.9 3.4 3.0 2.6	BS 63 90S-4	21	28-35
158.33 203.57 259.09	18.00 D 14.00 C 11.00 B	2.22 2.86 3.51	50 40 32	3.1 2.7 2.4	BS 63 80B-2	18	28-35
100.71 134.29 176.25	14.00 C 10.50 B 8.00 A	1.00 1.29 1.60	88 67 52	2.7 2.7 2.4	BS 50 90S-4	19	28-35
203.57 271.43 356.25	14.00 C 10.50 B 8.00 A	1.63 2.09 2.59	41 31 24	2.5 2.2 1.9	BS 50 80B-2	16	28-35
285.00 427.29	10.00 B 6.67 A	1.45 1.87	30 20	1.6 1.3	BS 40 80B-2	14	28-35

Worm geared motors

1.5 kW

Output speed n_2 rpm	Ratio i	Service factor f_{bp}	Output torque T_2 Nm	Permissible overhung load Fr_2 kN	Size	Weight kg	Dim. page																																																																																																																																																																																																																														
4.61	308.00 FB	0.76	1853	15.0	BS 112/63 90L 4	81	36-39																																																																																																																																																																																																																														
6.54	217.00 FA	0.99	1411	15.0				9.08	76.00 K	0.79	1080	15.0	BS 112 112M-8	91	28-35	12.37	76.00 K	1.07	807	15.0	BS 112 100L-6	83	28-35	14.92	63.00 J	1.44	697	15.0	13.15	108.00 M	0.76	692	15.0	BS 112 90L-4	74	28-35	14.95	95.00 L	1.00	635	15.0	18.68	76.00 K	1.55	536	15.0	22.54	63.00 J	1.89	462	15.0	30.87	46.00 H	2.78	350	15.0	36.41	39.00 G	3.19	300	15.0	16.21	58.00 J	0.90	620	10.0	BS 88 100L-6	65	28-35	20.00	71.00 K	0.90	485	10.0	BS 88 90L-4	57	28-35	24.48	58.00 J	1.15	424	10.0	30.21	47.00 H	1.44	352	10.0	36.41	39.00 G	1.77	296	10.0	48.97	29.00 F	2.30	228	9.7	60.43	23.50 E	2.44	196	9.0	72.82	19.50 D	3.01	165	8.2	90.62	15.67 C	3.56	135	7.4	50.71	28.00 F	1.00	225	5.0	BS 71 90L-4	27	28-35	67.62	21.00 E	1.30	177	4.6	88.75	16.00 D	1.62	138	4.0	118.33	12.00 C	2.05	105	3.5	152.20	9.33 B	2.62	83	3.0	189.33	7.50 A	2.97	68	2.7	238.33	12.00 C	3.25	49	2.9	57.96	24.50 E	0.78	204	4.0	BS 63 90L-4	24	28-35	78.89	18.00 D	0.98	152	3.9	101.43	14.00 C	1.26	122	3.4	129.09	11.00 B	1.54	97	3.0	183.23	7.75 A	1.94	69	2.6	158.89	18.00 D	1.55	71	3.1	204.29	14.00 C	2.00	57	2.7	BS 63 90S-2	21	28-35	260.00	11.00 B	2.46	46	2.4	369.03	7.75 A	3.11	32	2.1	135.24	10.50 B	0.94	93	2.7	BS 50 90L-4	22	28-35	177.50	8.00 A	1.16	71	2.4	204.29	14.00 C	1.15	57	2.5	BS 50 90S-2	19	28-35	272.38	10.50 B	1.48	44	2.2	357.50	8.00 A
9.08	76.00 K	0.79	1080	15.0	BS 112 112M-8	91	28-35																																																																																																																																																																																																																														
12.37	76.00 K	1.07	807	15.0	BS 112 100L-6	83	28-35																																																																																																																																																																																																																														
14.92	63.00 J	1.44	697	15.0				13.15	108.00 M	0.76	692	15.0	BS 112 90L-4	74	28-35	14.95	95.00 L	1.00	635	15.0	18.68	76.00 K	1.55	536	15.0	22.54	63.00 J	1.89	462	15.0	30.87	46.00 H	2.78				350	15.0	36.41	39.00 G	3.19	300	15.0	16.21	58.00 J	0.90	620	10.0	BS 88 100L-6	65	28-35	20.00	71.00 K	0.90	485	10.0	BS 88 90L-4	57	28-35	24.48	58.00 J	1.15	424	10.0	30.21	47.00 H	1.44	352	10.0	36.41	39.00 G	1.77	296	10.0				48.97	29.00 F	2.30	228	9.7	60.43	23.50 E	2.44	196	9.0	72.82	19.50 D	3.01	165	8.2	90.62	15.67 C	3.56	135	7.4	50.71	28.00 F	1.00	225	5.0	BS 71 90L-4	27	28-35	67.62	21.00 E	1.30	177	4.6	88.75	16.00 D	1.62	138	4.0	118.33	12.00 C				2.05	105	3.5	152.20	9.33 B	2.62	83	3.0	189.33	7.50 A	2.97	68	2.7	238.33	12.00 C	3.25	49	2.9	57.96	24.50 E	0.78	204	4.0	BS 63 90L-4	24	28-35	78.89	18.00 D	0.98	152	3.9	101.43	14.00 C	1.26	122				3.4	129.09	11.00 B	1.54	97	3.0	183.23	7.75 A	1.94	69	2.6	158.89	18.00 D	1.55	71	3.1	204.29	14.00 C	2.00	57	2.7	BS 63 90S-2	21	28-35	260.00	11.00 B	2.46	46	2.4	369.03	7.75 A	3.11	32	2.1	135.24	10.50 B	0.94	93	2.7	BS 50 90L-4	22	28-35	177.50	8.00 A	1.16	71	2.4	204.29	14.00 C	1.15	57	2.5	BS 50 90S-2	19	28-35	272.38	10.50 B	1.48	44	2.2	357.50	8.00 A	1.83	34	1.9						
13.15	108.00 M	0.76	692	15.0	BS 112 90L-4	74	28-35																																																																																																																																																																																																																														
14.95	95.00 L	1.00	635	15.0																																																																																																																																																																																																																																	
18.68	76.00 K	1.55	536	15.0																																																																																																																																																																																																																																	
22.54	63.00 J	1.89	462	15.0																																																																																																																																																																																																																																	
30.87	46.00 H	2.78	350	15.0																																																																																																																																																																																																																																	
36.41	39.00 G	3.19	300	15.0																																																																																																																																																																																																																																	
16.21	58.00 J	0.90	620	10.0				BS 88 100L-6	65	28-35																																																																																																																																																																																																																											
20.00	71.00 K	0.90	485	10.0				BS 88 90L-4	57	28-35																																																																																																																																																																																																																											
24.48	58.00 J	1.15	424	10.0																																																																																																																																																																																																																																	
30.21	47.00 H	1.44	352	10.0																																																																																																																																																																																																																																	
36.41	39.00 G	1.77	296	10.0																																																																																																																																																																																																																																	
48.97	29.00 F	2.30	228	9.7																																																																																																																																																																																																																																	
60.43	23.50 E	2.44	196	9.0																																																																																																																																																																																																																																	
72.82	19.50 D	3.01	165	8.2																																																																																																																																																																																																																																	
90.62	15.67 C	3.56	135	7.4																																																																																																																																																																																																																																	
50.71	28.00 F	1.00	225	5.0	BS 71 90L-4	27	28-35																																																																																																																																																																																																																														
67.62	21.00 E	1.30	177	4.6																																																																																																																																																																																																																																	
88.75	16.00 D	1.62	138	4.0																																																																																																																																																																																																																																	
118.33	12.00 C	2.05	105	3.5																																																																																																																																																																																																																																	
152.20	9.33 B	2.62	83	3.0																																																																																																																																																																																																																																	
189.33	7.50 A	2.97	68	2.7																																																																																																																																																																																																																																	
238.33	12.00 C	3.25	49	2.9																																																																																																																																																																																																																																	
57.96	24.50 E	0.78	204	4.0	BS 63 90L-4	24	28-35																																																																																																																																																																																																																														
78.89	18.00 D	0.98	152	3.9																																																																																																																																																																																																																																	
101.43	14.00 C	1.26	122	3.4																																																																																																																																																																																																																																	
129.09	11.00 B	1.54	97	3.0																																																																																																																																																																																																																																	
183.23	7.75 A	1.94	69	2.6																																																																																																																																																																																																																																	
158.89	18.00 D	1.55	71	3.1																																																																																																																																																																																																																																	
204.29	14.00 C	2.00	57	2.7	BS 63 90S-2	21	28-35																																																																																																																																																																																																																														
260.00	11.00 B	2.46	46	2.4																																																																																																																																																																																																																																	
369.03	7.75 A	3.11	32	2.1																																																																																																																																																																																																																																	
135.24	10.50 B	0.94	93	2.7	BS 50 90L-4	22	28-35																																																																																																																																																																																																																														
177.50	8.00 A	1.16	71	2.4																																																																																																																																																																																																																																	
204.29	14.00 C	1.15	57	2.5	BS 50 90S-2	19	28-35																																																																																																																																																																																																																														
272.38	10.50 B	1.48	44	2.2																																																																																																																																																																																																																																	
357.50	8.00 A	1.83	34	1.9																																																																																																																																																																																																																																	

Worm geared motors

2.2 kW

Output speed n_2 rpm	Ratio i	Service factor f_{bp}	Output torque T_2 Nm	Permissible overhung load Fr_2 kN	Size	Weight kg	Dim. page
14.76	63.00 J	0.96	1048	15.0	BS 112 112M-6	91	28-35
18.82	76.00 K	1.04	802	15.0	BS 112 100LA-4	81	28-35
22.70	63.00 J	1.26	691	15.0			
31.09	46.00 H	1.86	524	15.0			
36.67	39.00 G	2.13	450	15.0			
51.07	28.00 F	2.70	331	15.0			
62.17	23.00 E	3.23	288	13.6			
30.43	47.00 H	0.97	523	10.0			
36.67	39.00 G	1.19	440	10.0			
49.31	29.00 F	1.54	339	9.7			
60.85	23.50 E	1.64	291	9.0			
73.33	19.50 D	2.03	245	8.2			
91.26	15.67 C	2.39	201	7.4			
121.70	11.75 B	3.18	154	6.3			
89.38	16.00 D	1.10	204	4.0	BS 71 100LA-4	32	28-35
119.17	12.00 C	1.39	155	3.5			
153.27	9.33 B	1.77	123	3.0			
190.67	7.50 A	2.01	100	2.7			
239.17	12.00 C	2.13	75	2.9	BS 71 90L-2	27	28-35
307.61	9.33 B	2.74	60	2.4			
382.67	7.50 A	3.15	48	2.2			
102.14	14.00 C	0.85	181	3.4	BS 63 100LA-4	29	28-35
130.00	11.00 B	1.04	144	3.0			
184.52	7.75 A	1.31	102	2.6			
205.00	14.00 C	1.31	88	2.7	BS 63 90L-2	24	28-35
260.91	11.00 B	1.61	70	2.4			
370.32	7.75 A	2.04	50	2.1			
358.75	8.00 A	1.21	51	1.9	BS 50 90L-2	22	28-35

Worm geared motors

3 kW

22.70	63.00 J	0.91	957	15.0	BS 112 100LB-4	84	28-35
31.09	46.00 H	1.34	726	15.0			
36.67	39.00 G	1.54	623	15.0			
51.07	28.00 F	1.95	458	15.0			
62.17	23.00 E	2.33	398	13.6			
73.33	19.50 D	2.70	338	12.8			
93.46	15.30 C	3.42	274	11.0			
60.85	23.50 E	1.19	402	9.0	BS 88 100LB-4	66	28-35
73.33	19.50 D	1.47	337	8.2			
91.26	15.67 C	1.74	277	7.4			
121.70	11.75 B	2.31	212	6.3			
197.24	7.25 A	3.35	134	5.0			
245.96	11.75 B	3.58	103	5.1	BS 88 100L-2	63	28-35
153.27	9.33 B	1.29	170	3.0	BS 71 100LB-4	35	28-35
190.67	7.50 A	1.46	138	2.7			
240.83	12.00 C	1.54	104	2.9	BS 71 100L-2	32	28-35
309.75	9.33 B	1.97	83	2.4			
385.33	7.50 A	2.27	66	2.2			
184.52	7.75 A	0.95	141	2.6	BS 63 100LB-4	32	28-35
262.73	11.00 B	1.16	96	2.4	BS 63 100L-2	29	28-35
372.90	7.75 A	1.47	69	2.1			

Worm geared motors

4 kW

Output speed n_2 rpm	Ratio i	Service factor f_{bp}	Output torque T_2 Nm	Permissible overhung load Fr_2 kN	Size	Weight kg	Dim. page
30.98	46.00 H	0.99	981	15.0	BS 112 112M-4	91	28-35
36.54	39.00 G	1.14	842	15.0			
50.89	28.00 F	1.44	619	15.0			
61.96	23.00 E	1.72	538	13.6			
73.08	19.50 D	2.00	456	12.8			
93.14	15.30 C	2.53	370	11.0			
123.91	11.50 B	3.17	281	9.5			
73.08	19.50 D	1.09	455	8.2	BS 88 112M-4	73	28-35
90.94	15.67 C	1.29	374	7.4			
121.28	11.75 B	1.71	286	6.3			
196.55	7.25 A	2.49	180	5.0			
241.70	11.75 B	2.59	142	5.1	BS 88 112M-2	72	28-35
304.39	9.33 B	1.43	114	2.4	BS 71 112M-2	41	28-35
378.67	7.50 A	1.65	92	2.2			

Worm geared motors

5.5 kW

Output speed n_2 rpm	Ratio i	Service factor f_{bp}	Output torque T_2 Nm	Permissible overhung load Fr_2 kN	Size	Weight kg	Dim. page
50.89	28.00 F	1.04	858	15.0	BS 112 132S-4	107	28-35
61.96	23.00 E	1.24	746	13.6			
73.08	19.50 D	1.44	633	12.8			
93.14	15.30 C	1.82	513	11.0			
123.91	11.50 B	2.29	390	9.5			
203.57	7.00 A	3.36	240	7.6			
249.13	11.50 B	3.72	190	7.5			
121.28	11.75 B	1.24	396	6.3	BS 88 132S-4	90	28-35
196.55	7.25 A	1.80	250	5.0			
243.83	11.75 B	1.87	197	5.1	BS 88 132SA-2	92	28-35
395.17	7.25 A	2.92	123	4.0			

Worm geared motors

7.5 kW

Output speed n_2 rpm	Ratio i	Service factor f_{bp}	Output torque T_2 Nm	Permissible overhung load Fr_2 kN	Size	Weight kg	Dim. page
62.17 73.33 93.46 124.35 204.29	23.00 E 19.50 D 15.30 C 11.50 B 7.00 A	0.91 1.05 1.33 1.67 2.46	1020 865 701 533 328	13.6 12.8 11.0 9.5 7.6	BS 112 132M-4	117	28-35
249.57 410.00	11.50 B 7.00 A	2.70 3.75	263 162	7.5 6.2	BS 112 132SB-2	109	28-35
197.24	7.25 A	1.32	341	5.0	BS 88 132M-4	100	28-35
244.26 395.86	11.75 B 7.25 A	1.36 2.12	271 169	5.1 4.0	BS 88 132SB-2	92	28-35

Worm geared motors

9 kW

Output speed n_2 rpm	Ratio i	Service factor f_{bp}	Output torque T_2 Nm	Permissible overhung load Fr_2 kN	Size	Weight kg	Dim. page
73.33 93.46 124.35 204.29	19.50 D 15.30 C 11.50 B 7.00 A	0.88 1.11 1.39 2.04	1041 844 641 394	12.8 11.0 9.5 7.6	BS 112 132MD-4	129	28-35
256.96 422.14	11.50 B 7.00 A	2.30 3.20	308 190	7.5 6.2	BS 112 132ME-2	132	28-35
251.49 407.59	11.75 B 7.25 A	1.16 1.81	317 198	5.1 4.0	BS 88 132ME-2	115	28-35

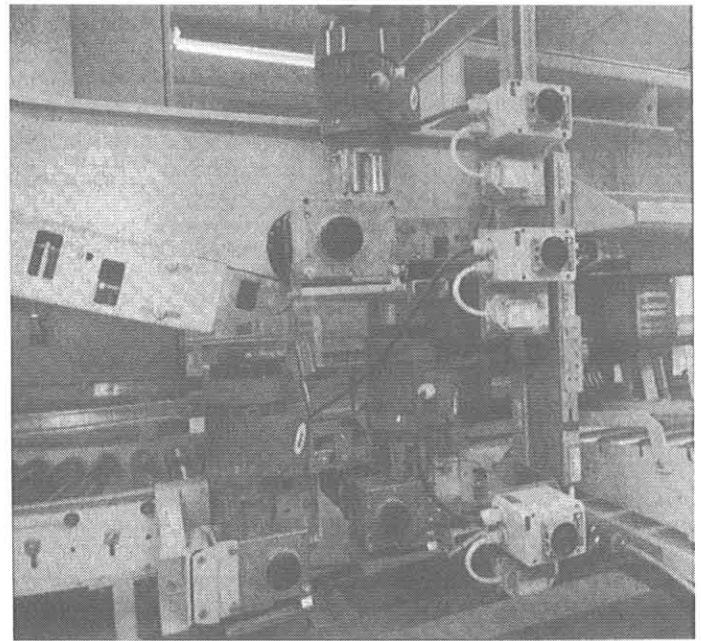
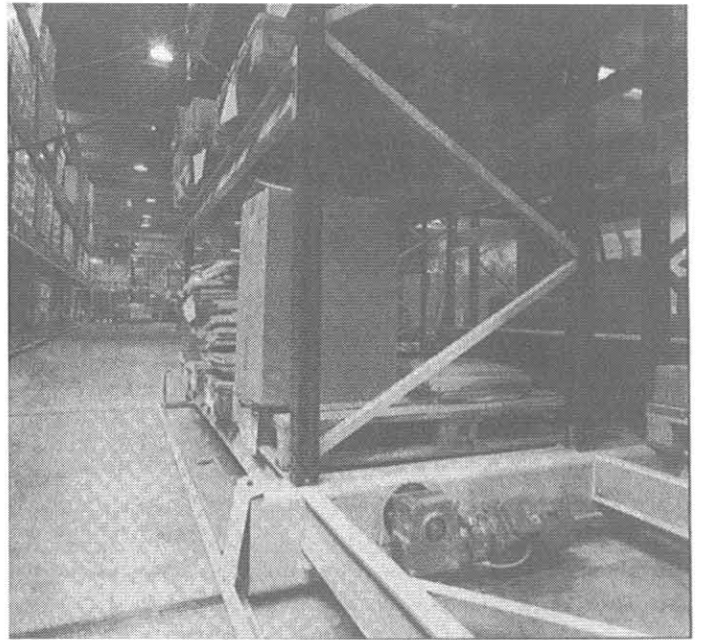
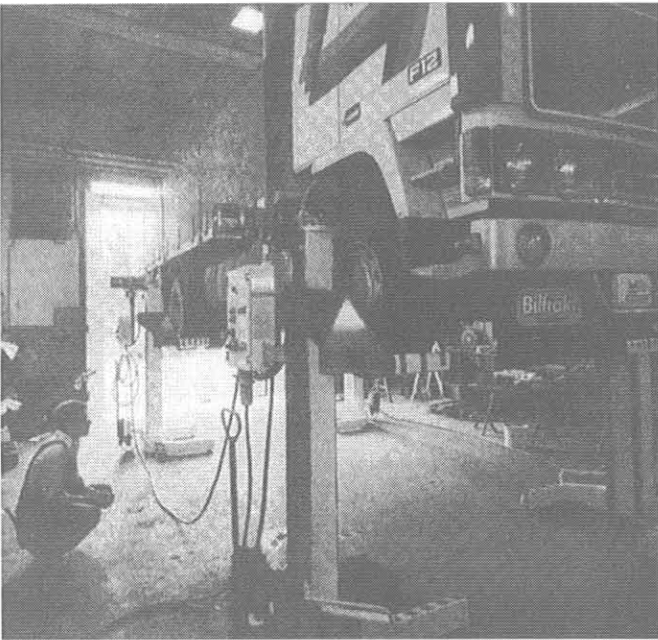
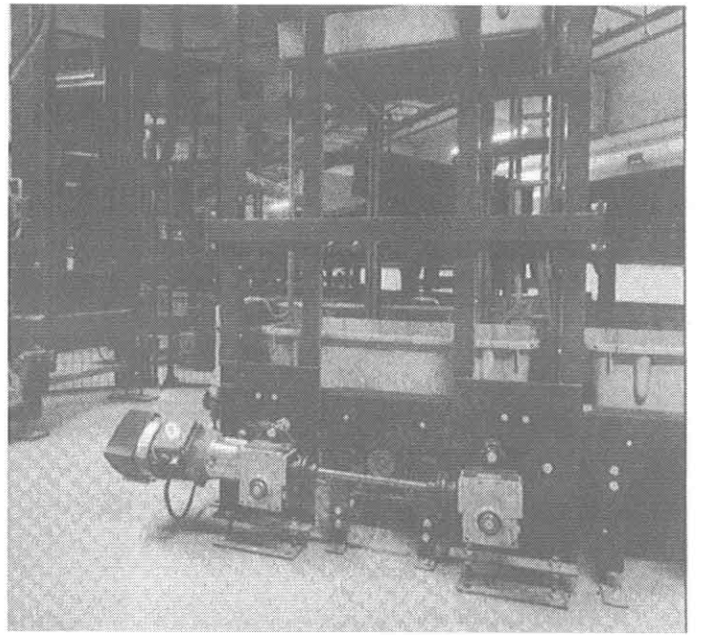
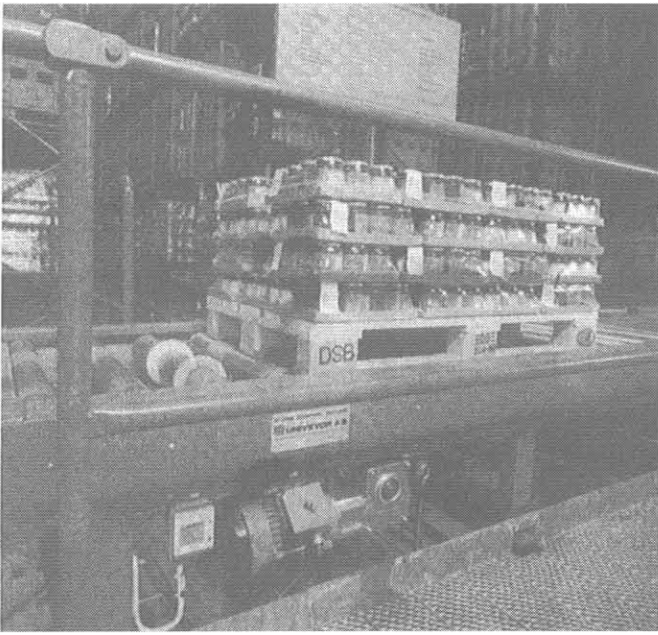

Worm geared motors BS35 Shaftmounted

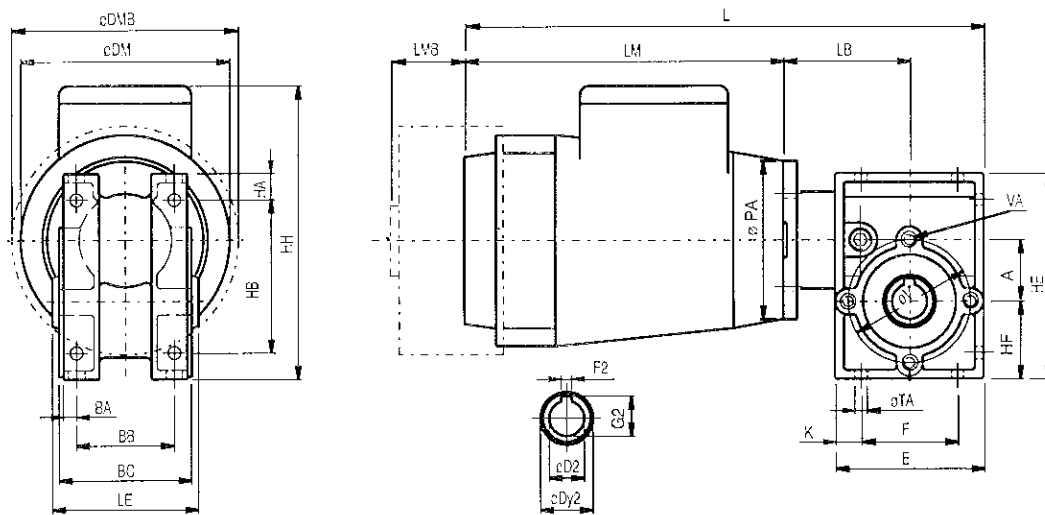

Gear	Motor size	BA	BB	BC	LE	HA	HB	HH	L	LM	LB	ø PA	HF	A	HE	ø V
BS 35	63	7.5	56	74	82	15.5	87	167	297.5	183	72	90	45	35	118	70
BS 35	71	7.5	56	74	82	15.5	87	181	334.5	210	82	90	45	35	118	70

Gear	Motor size	VA	ø TA	K	F	E	øD2 H7	G2	F2 JS9	øDY2	øDM	øDMB	LMB
BS 35	63	M6x9 (4x)	7.5 (12x)	14.5	56	85	20	22.8	6	30	120	120	49
BS 35	71	M6x9 (4x)	7.5 (12x)	14.5	56	85	20	22.8	6	30	140	150	102

Worm geared motors BS35 Footmounted

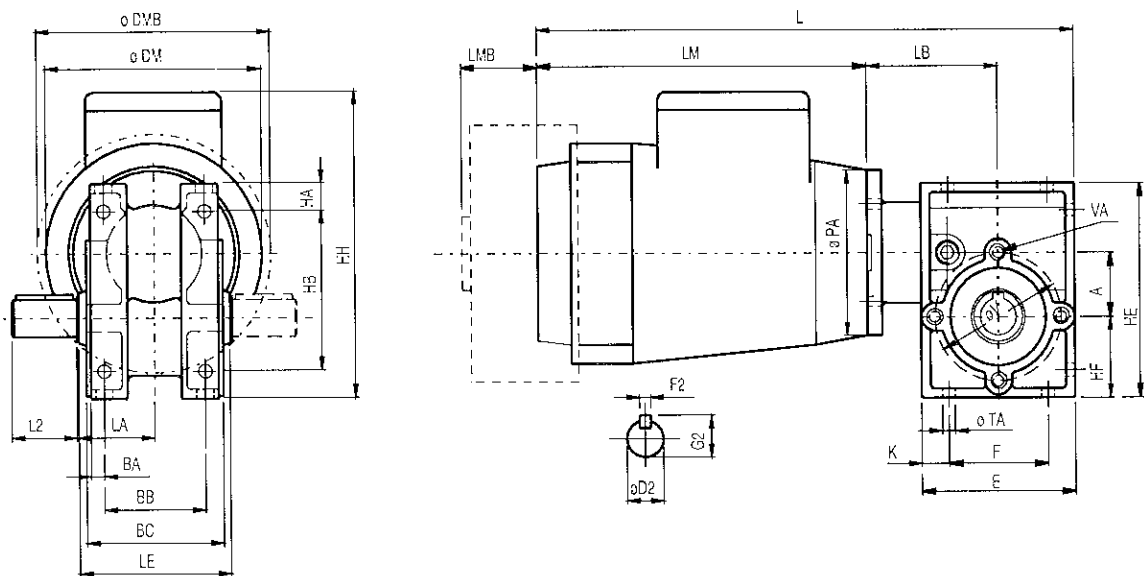

Gear	Motor size	LA	L2	BA	BB	BC	LE	HA	HB	HH	L	LM	LB	ø PA	HF	A
BS 35	63	42	36	7.5	56	74	82	15.5	87	167	297.5	183	72	90	45	35
BS 35	71	42	36	7.5	56	74	82	15.5	87	181	334.5	210	82	90	45	35

Gear	Motor size	HE	ø V	VA	ø TA	K	F	E	øD2 j6	G2	F2 h9	øDM	øDMB	LMB
BS 35	63	118	70	M6x9 (4x)	7.5 (12x)	14.5	56	85	20	22.5	6	120	120	49
BS 35	71	118	70	M6x9 (4x)	7.5 (12x)	14.5	56	85	20	22.5	6	140	150	102

Worm geared motors BS35 Flangemounted

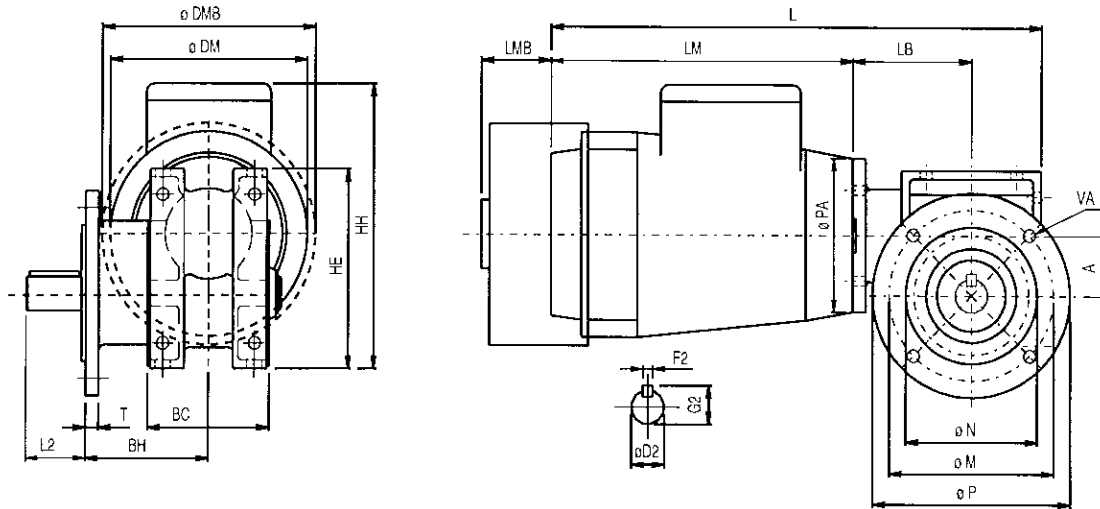

Gear	Motor size	BC	BH	T	L2	HE	HH	L	LM	LB	$\varnothing PA$	A
BS 35	63	74	75	8	36	118	167	297.5	183	72	90	35
BS 35	71	74	75	8	36	118	181	334.5	210	82	90	35

Gear	Motor size	$\varnothing VA$	$\varnothing M$	$\varnothing P$	$\varnothing N h7$	$\varnothing D2 j6$	$F2 h9$	G2	$\varnothing DM$	$\varnothing DMB$	LMB
BS 35	63	7.5	100	120	80	20	6	22.5	120	120	49
BS 35	71	7.5	100	120	80	20	6	22.5	140	150	102

Worm geared motors BS35 Foot/flangemounted

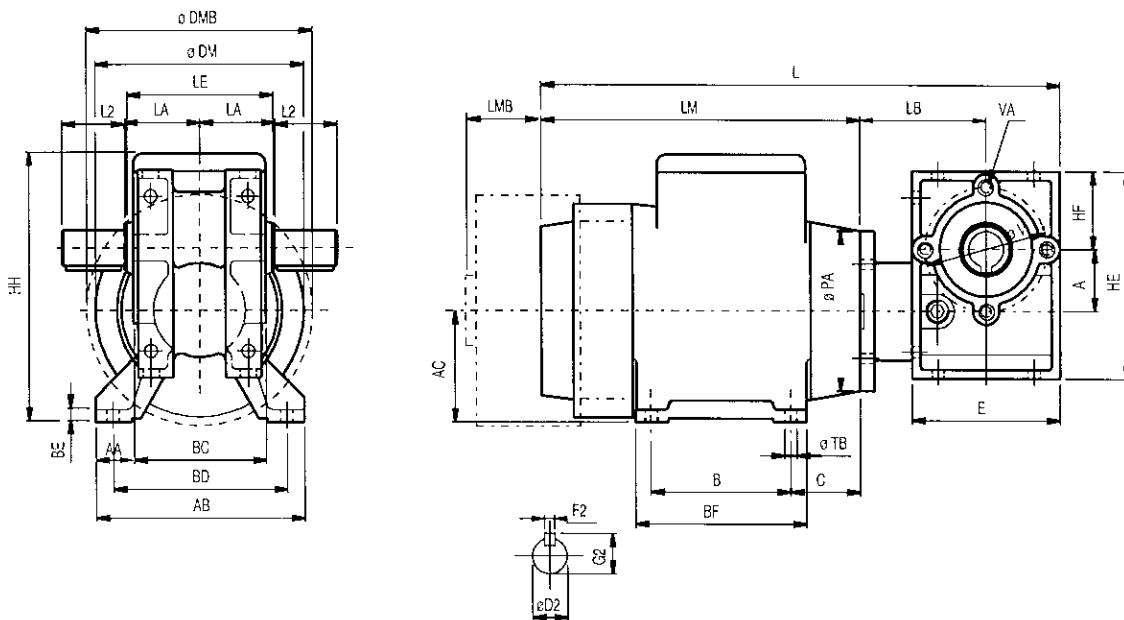

Gear	Motor size	LA	L2	BD	BE	BC	LE	BF	AA	H,	L	LM	LB	$\varnothing PA$	HF	A	HE
BS 35	63	42	36	100	7	74	82	98	16	150	297.5	183	72	90	45	35	118
BS 35	71	42	36	112	9	74	82	112	20	172	334.5	210	82	90	45	35	118

Gear	Motor size	$\varnothing V$	VA	$\varnothing TB$	AB	B	C	$\varnothing D2 j6$	G2	$F2 h9$	AC	$\varnothing DM$	$\varnothing DMB$	LMB
BS 35	63	70	M6x9 (4x)	7 (4x)	120	80	40	20	22.5	6	63	120	120	49
BS 35	71	70	M6x9 (4x)	7 (4x)	136	90	45	20	22.5	6	71	140	150	102

Worm geared motors BS40-112 Shaftmounted

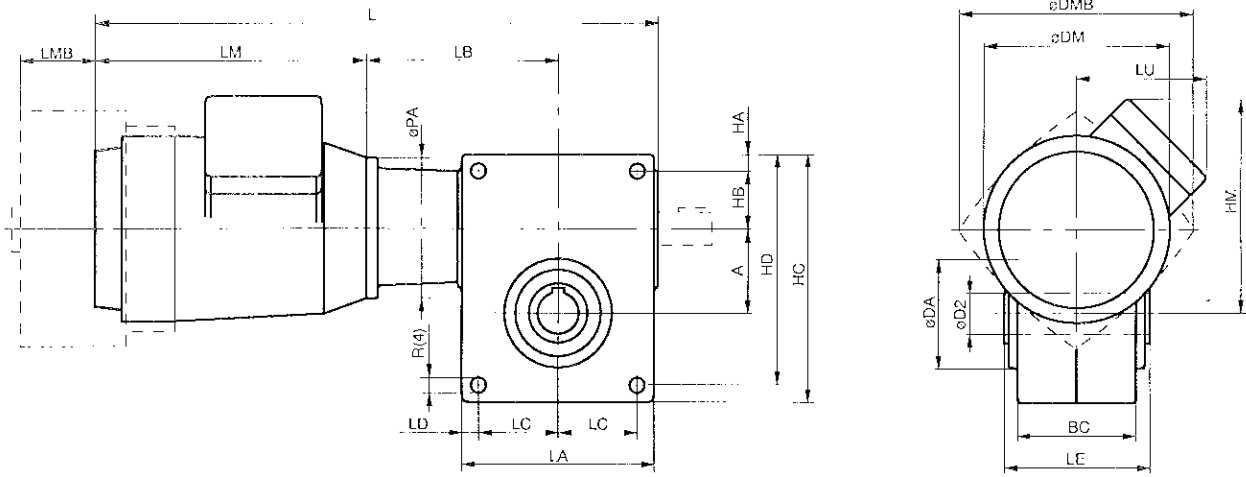

BS 40-71

Mounting position O, hollow shaft

Position of terminal box, see page 11

Shaft tolerance, see page 57

BS	Motor-size	Motor dimensions				Gear unit dimensions												
		B14		B5		A	BC	øDA	HA	HB	HC	HD	HE	HH	HJ	LA	LC	øR
		L	LB	L	LB													
40	63	355	112	355	112													
	71	388	118	388	118													
	80	420	128	420	128	40	73	58	10	36	140	130			100	40	8.3	
	90 S	443	138	443	138													
	90 L	468	138	468	138													
50	71	421	140	421	140													
	80	453	150	463	160													
	90 S	476	160	476	160	50	78	68	10	38	155	145			124	52	8.3	
	90 L	501	160	501	160													
63	71	443	151	443	151													
	80	475	161	485	171													
	90 S	498	171	498	171	63	82	80	10	43	183	173			146	63	10.3	
	90 L	523	171	523	171													
	100	561.5	181.5	561.5	181.5													
71	80	495	177	505	187													
	90 S	518	187	518	187													
	90 L	543	187	543	187	71	101.4	92	14	49	209	195			165	68.5	12.3	
	100	581.5	197.5	581.5	197.5													
	112	595.5	197.5	595.5	197.5													
88	80 (i>55)	577	213	587	223													
	90 S	600	223	600	223													
	90 L	625	223	625	223	88							275	203	115			
	100	664	233.5	664	233.5													
	112	678	233.5	678	233.5													
	132 (i<55)			779	266													
112	90 S (i>60)	642	244	642	244													
	90 L (i>60)	667	244	667	244													
	100 (i>60)	705	254.5	705	254.5													
	100	718	267	718	267	112							340	252	140			
	112 (i>60)	720	254.5	720	254.5													
	112	732	267	732	267													
	132			821	287													
	160			956	317													

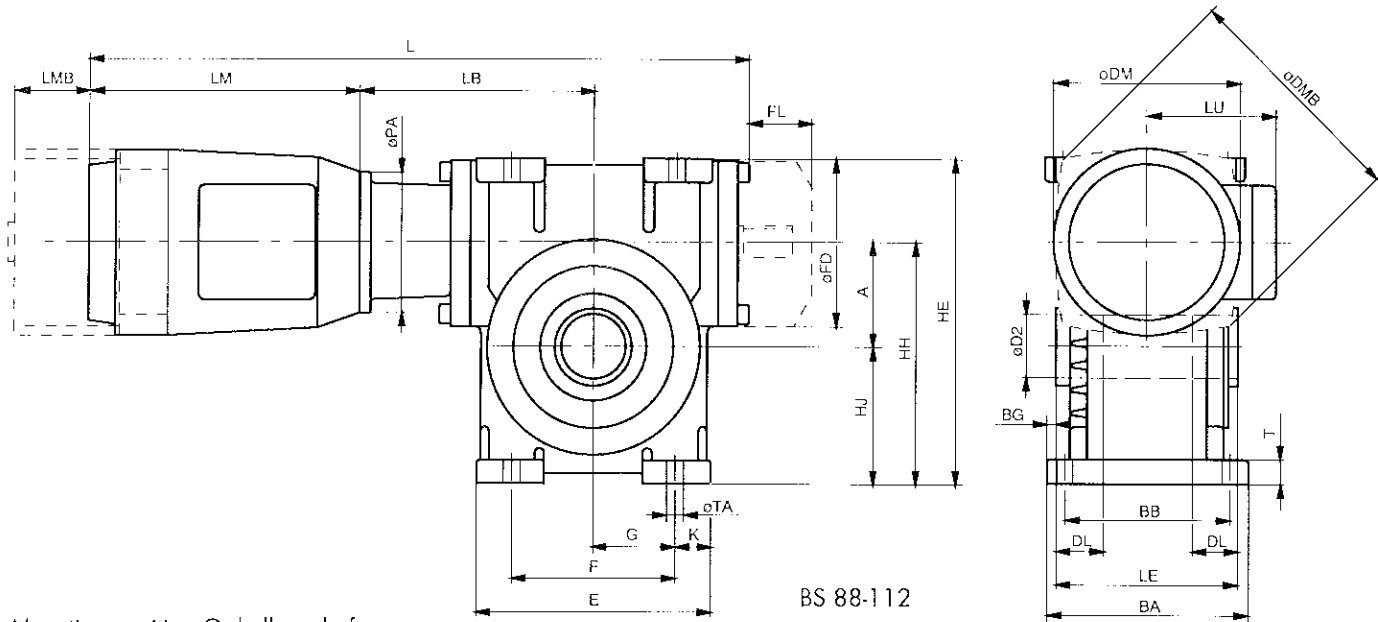

Mounting position O, hollow shaft

Position of terminal box, see page 11

Shaft tolerance, see page 57

										Shaft-dimensions	Fan		Motor dimensions					With brake motor			
BA	BB	BG	E	F	G	K	T	øTA	øD2	LE	DL	FD	FL	DM	HM	LM	LU	PA-B14	PA-B5	DMB	LMB
									20	92				120	125	183	92	90	140		
														140	140	210	102	105	160	185	73
														158	152	232	113	120	200	201	72
														178	161	245	122	140	200	220	75
														178	161	270	122	140	200	220	75
									25	98				140	150	210	102	105	160	185	73
														158	162	232	113	120	200	201	72
														178	172	245	122	140	200	220	75
														178	172	270	122	140	200	220	75
									30	101				140	163	210	102	105	160	185	73
														158	175	232	113	120	200	201	72
														178	184	245	122	140	200	220	75
														178	184	270	122	140	200	220	75
														198	204	298	136	160	250	255	106
									35	122				158	183	232	113	120	200	201	72
														178	192	245	122	140	200	220	75
														178	192	270	122	140	200	220	75
														198	212	298	136	160	250	255	106
														221	231	312	155	160	250	278	109
														158	200	232	113	120	200	201	72
170	140	8	200	140	70	30	20	14	45	154	45	140	55	178	209	245	122	140	200	220	75
														178	209	270	122	140	200	220	75
														198	229	298	136	160	250	255	106
														221	248	312	155	160	250	278	109
														248	255	381	165		300	317	135
														178	233	245	122	140	200	220	75
														178	233	270	122	140	200	220	75
														198	253	298	136	160	250	255	106
210	175	18	250	175	87.5	37.5	23	18	55	174	50	140	55	198	253	298	136	160	250	255	106
														221	272	312	155	160	250	278	109
														221	272	312	155	160	250	278	109
														248	279	381	165		300	317	135
														310	332	486	210		350	375	170

Worm geared motors BS40-112 Footmounted

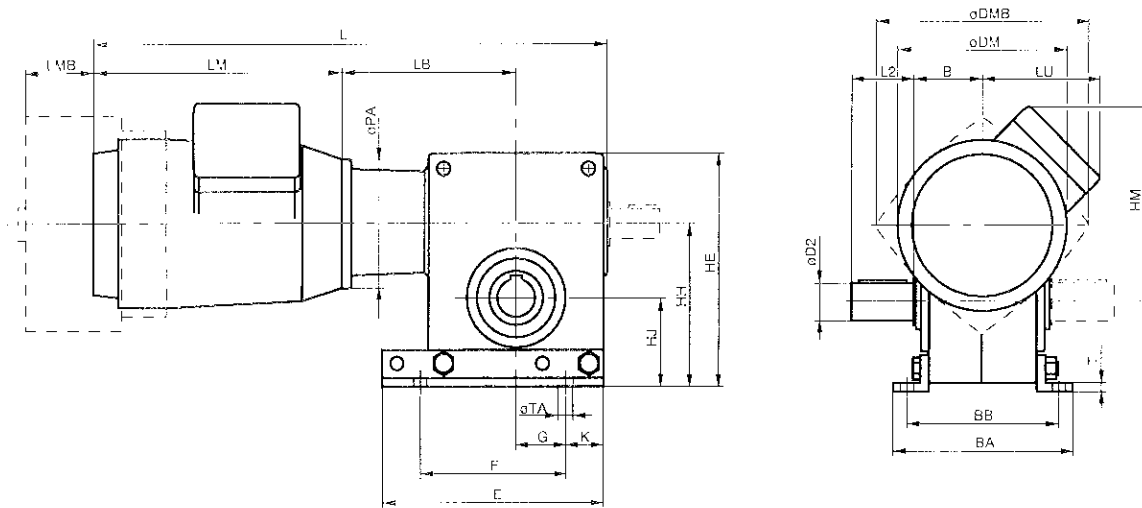

BS 40-71

Mounting position OV, OH, OD

Position of terminal box, see page 11

Shaft tolerance, see page 57

BS	Motor-size	B14 Motor dimensions		B5		Gear unit dimensions												
		L	LB	L	LB	B	HE	HH	HJ	BA	BB	E	F	G	K	T	TA	
40	63	355	112	355	112													
	71	388	118	388	118													
	80	420	128	420	128	47	152	106	66	133	108	140	80	20	30	5	8.5	
	90 S	443	138	443	138													
	90 L	468	138	468	138													
50	71	421	140	421	140													
	80	453	150	463	160	50	167	119	69	138	113	155	104	36.5	25.5	5	8.5	
	90 S	476	160	476	160													
	90 L	501	160	501	160													
63	71	443	151	443	151													
	80	475	161	485	171													
	90 S	498	171	498	171	52	195	142	79	146	121	183	126	44.5	28.5	7	10.5	
	90 L	523	171	523	171													
	100	561.5	181.5	561.5	181.5													
71	80	495	177	505	187													
	90 S	518	187	518	187													
	90 L	543	187	543	187	62.5	216.5	153.5	82.5	170	144	209	137	46.5	36	8	12.5	
	100	581.5	197.5	581.5	197.5													
	112	595.5	197.5	595.5	197.5													
88	80 (i>55)	577	213	587	223													
	90 S	600	223	600	223													
	90 L	625	223	625	223	70	275	203	115	170	140	140	200	70	30	20	14	
	100	664	233.5	664	233.5													
	112	678	233.5	678	233.5													
	132 (i<55)			779	266													
112	90 S (i>60)	642	244	642	244													
	90 L (i>60)	667	244	667	244													
	100 (i>60)	705	254.5	705	254.5													
	100	718	267	718	267	82	340	252	140	210	175	175	250	87.5	37.5	23	18	
	112 (i>60)	720	254.5	720	254.5													
	112	732	267	732	267													
	132			821	287													
	160			956	317													

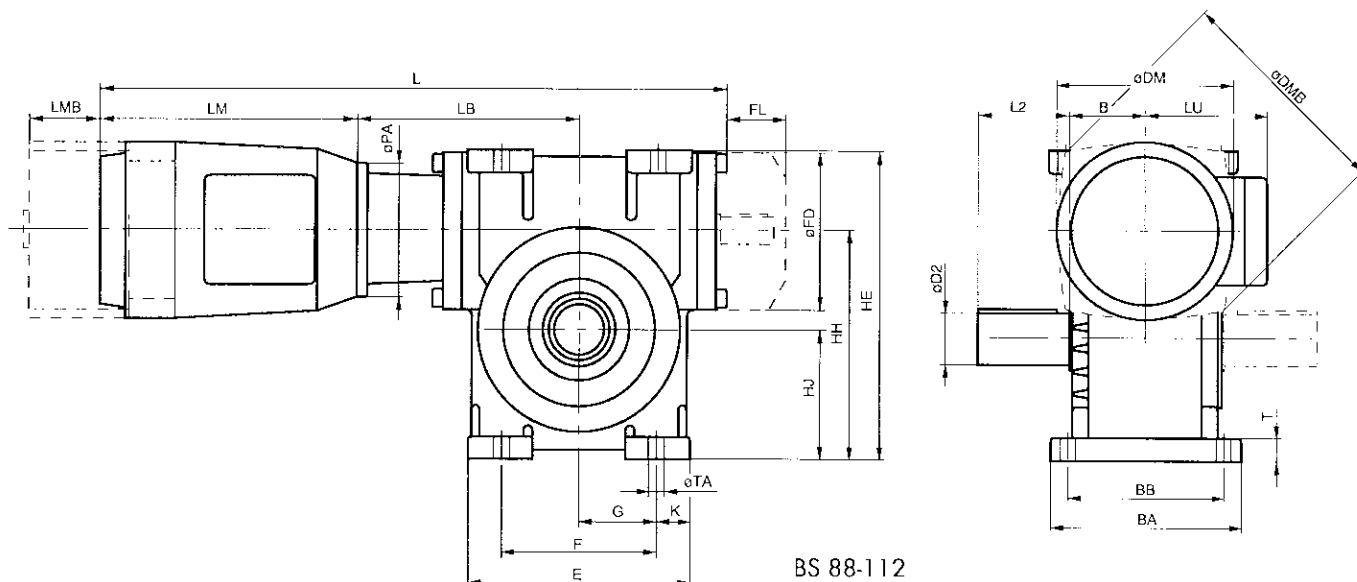

Mounting position OV, OH, OD

Position of terminal box, see page 11

Shaft tolerance, see page 57

Shaft-dimensions		Fan		Motor dimensions						With brake motor	
D2	L2	FD	FL	DM	HM	LM	LU	PA-B14	PA-B5	DMB	LMB
20	36			120	125	183	85	90	140		
				140	140	210	100	105	160	185	73
				158	152	232	112	120	200	201	72
				178	161	245	121	140	200	220	75
				178	161	270	121	140	200	220	75
25	42			140	135	210	100	105	160	185	73
				158	150	232	112	120	200	201	72
				178	171	245	121	140	200	220	75
				178	171	270	121	140	200	220	75
30	58			140	163	210	100	105	160	185	73
				158	175	232	112	120	200	201	72
				178	184	245	121	140	200	220	75
				178	184	270	121	140	200	220	75
				198	204	298	141	160	250	255	106
35	58			158	183	232	112	120	200	201	72
				178	192	245	121	140	200	220	75
				178	192	270	121	140	200	220	75
				198	212	298	141	160	250	255	106
				221	231	312	160	160	250	278	109
45	82	140	55	158		232	112	120	200	201	72
				178		245	121	140	200	220	75
				178		270	121	140	200	220	75
				198		298	136	160	250	255	106
				221		312	156	160	250	278	109
				248		381	167		300	317	135
55	82	140	55	178		245	121	140	200	220	75
				178		270	121	140	200	220	75
				198		298	136	160	250	255	106
				198		298	136	160	250	255	106
				221		312	156	160	250	278	109
				221		312	156	160	250	278	109
				248		381	167		300	317	135
310		486	210		350	375	170				

Worm geared motors BS40-112 Footmounted

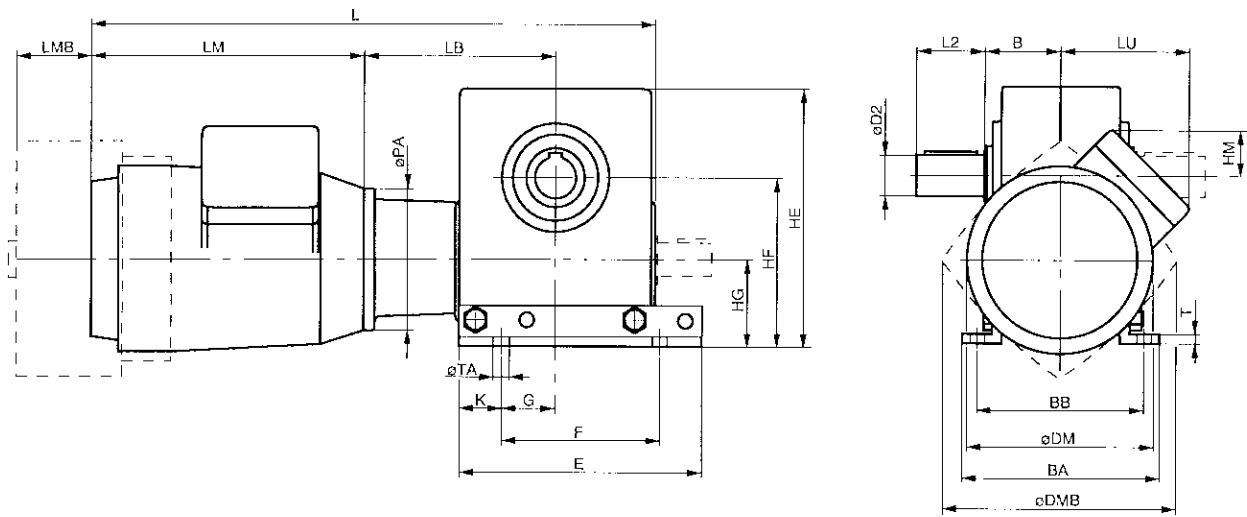

BS 40-71

Mounting position UV, UH, UD

Position of terminal box, see page 11

Shaft tolerance, see page 57

BS	Motor-size	Motor dimensions				Gear unit dimensions											
		B14		B5		B	HE	HF	HG	BA	BB	E	F	G	K	T	TA
		L	LB	L	LB												
40	63	355	112	355	112												
	71	388	117	388	118												
	80	420	128	420	128	47	152	98	58	133	108	140	80	20	30	5	8.5
	90 S	443	138	443	138												
	90 L	468	138	468	138												
50	71	421	140	421	140												
	80	453	150	463	160	50	167	110	60	138	113	155	104	36.5	25.5	5	8.5
	90 S	476	160	476	160												
	90 L	501	160	501	160												
63	71	443	151	443	151												
	80	475	161	485	171												
	90 S	498	171	498	171	52	195	128	65	146	121	183	126	44.5	28.5	7	10.5
	90 L	523	171	523	171												
	100	561.5	181.5	561.5	181.5												
71	80	495	177	505	187												
	90 S	518	187	518	187												
	90 L	543	187	543	187	62.5	216.5	141.5	70.5	169.4	143.4	209	137	46.5	36	8	12.5
	100	581.5	197.5	581.5	197.5												
	112	595.5	197.5	595.5	197.5												
88	80 (i>55)	577	213	587	223												
	90 S *	600	223	600	223												
	90 L	625	223	625	223	70	275	160	72	170	140	140	200	70	30	20	14
	100	664	233.5	664	233.5												
	112	678	233.5	678	233.5												
	132 (i<55)			779	266												
112	90 S (i>60)	642	244	642	244												
	90 L (i>60)	667	244	667	244												
	100 (i>60)	705	254.5	705	254.5												
	100	718	267	718	267	82	340	200	88	210	175	175	250	87.5	37.5	23	18
	112 (i>60)	720	254.5	720	254.5												
	112	732	267	732	267												
	132			821	287												
	160			956	317												

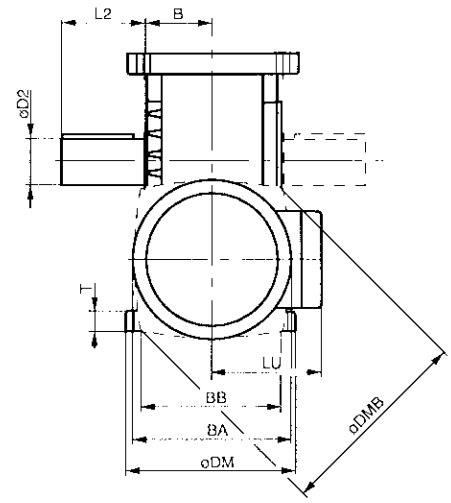
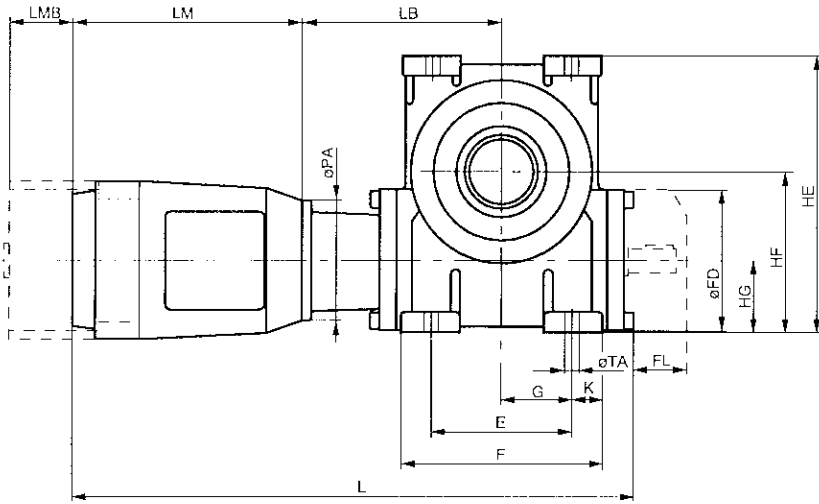

BS 88-112

Mounting position UV, UH, UD

Position of terminal box, see page 11

Shaft tolerance, see page 57

Shaft-dimensions		Fan		Motor dimensions				With brake motor			
D2	L2	FD	FL	DM	HM	LM	LU	PA-B14	PA-B5	DMB	LMB
20	36			120	45	183	85	90	140		
				140	60	210	100	105	160	185	73
				158	72	232	112	120	200	201	72
				178	81	245	121	140	200	220	75
				178	81	270	121	140	200	220	75
25	42			140	50	210	100	105	160	185	73
				158	62	232	112	120	200	201	72
				178	71	245	121	140	200	220	75
				178	71	270	121	140	200	220	75
				140	37	210	100	105	160	185	73
30	58			158	49	232	112	120	200	201	72
				178	58	245	121	140	200	220	75
				178	58	270	121	140	200	220	75
				198	78	298	141	160	250	255	106
				158	41	232	112	120	200	201	72
35	58			178	50	245	121	140	200	220	75
				178	50	270	121	140	200	220	75
				198	70	298	141	160	250	255	106
				221	89	312	160	160	250	278	109
				158		232	112	120	200	201	72
45	82	140	55	178		245	121	140	200	220	75
				178		270	121	140	200	220	75
				198		298	136	160	250	255	106
				221		312	156	160	250	278	109
				248		381	167		300	317	135
55	82	140	55	178		245	121	140	200	220	75
				178		270	121	140	200	220	75
				198		298	136	160	250	255	106
				198		298	136	160	250	255	106
				221		312	156	160	250	278	109
248		381	167		300	317	135				
310		486	210		350	375	170				

Worm geared motors BS40-112 Flangemounted

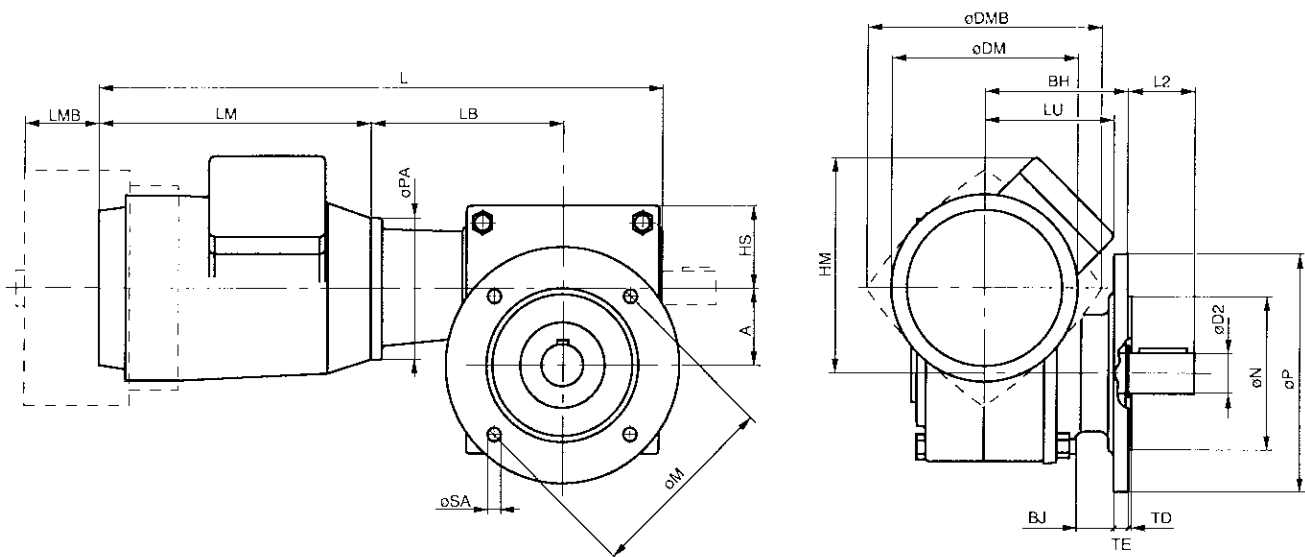

BS 40-71

Mounting position OH

Position of terminal box, see page 11

Shaft tolerance, see page 57

BS	Motor-size	Motor dimensions				Gear unit dimensions									
		B14		B5		A	HS	BJ	M	N	P	øSA	TE	TD	BH
		L	LB	L	LB										
40	63	355	112	355	112										
	71	388	117	388	118				100	80	118				
	80	420	128	420	128	40	46	28	115 ¹⁾	95 ¹⁾	140 ¹⁾	9	10	3	91.5
	90 S	443	138	443	138				130	110	160				
	90 L	463	138	468	138				165	130	200				
50	71	421	140	421	140				100	80	118				
	80	453	150	463	160				115	95	140	9	10	3.5	99
	90 S	476	160	476	160	50	48	28	130 ¹⁾	110 ¹⁾	160 ¹⁾				
	90 L	501	160	501	160				165	130	200				
63	71	443	151	443	151										
	80	475	161	485	171				130	110	160				
	90 S	498	171	498	171	63	53	35	165 ¹⁾	130 ¹⁾	200 ¹⁾	11	12	3.5	106
	90 L	523	171	523	171										
	100	561.5	181.5	561.5	181.5										
71	80	495	177	505	187										
	90 S	518	187	518	187										
	90 L	543	187	543	187	71	63	32	165	130	200	11	12	3.5	122.4
	100	581.5	197.5	581.5	197.5										
	112	595.5	197.5	595.5	197.5										
88	80 (i>55)	577	213	587	223										
	90 S	600	223	600	223										
	90 L	625	223	625	223	88	72	24	215	180	250	14	15	4	105
	100	664	233.5	664	233.5										
	112	678	233.5	678	233.5										
	132 (i<55)			779	266										
112	90 S (i>60)	642	244	642	244										
	90 L (i>60)	667	244	667	244										
	100 (i>60)	705	254.5	705	254.5										
	100	718	267	718	267	112	88	32	265	230	300	14	15	4	125
	112 (i>60)	720	254.5	720	254.5										
	112	732	267	732	267										
	132			821	287										
	160			956	317										

¹⁾ Standardutförande, övriga på förfrågan.

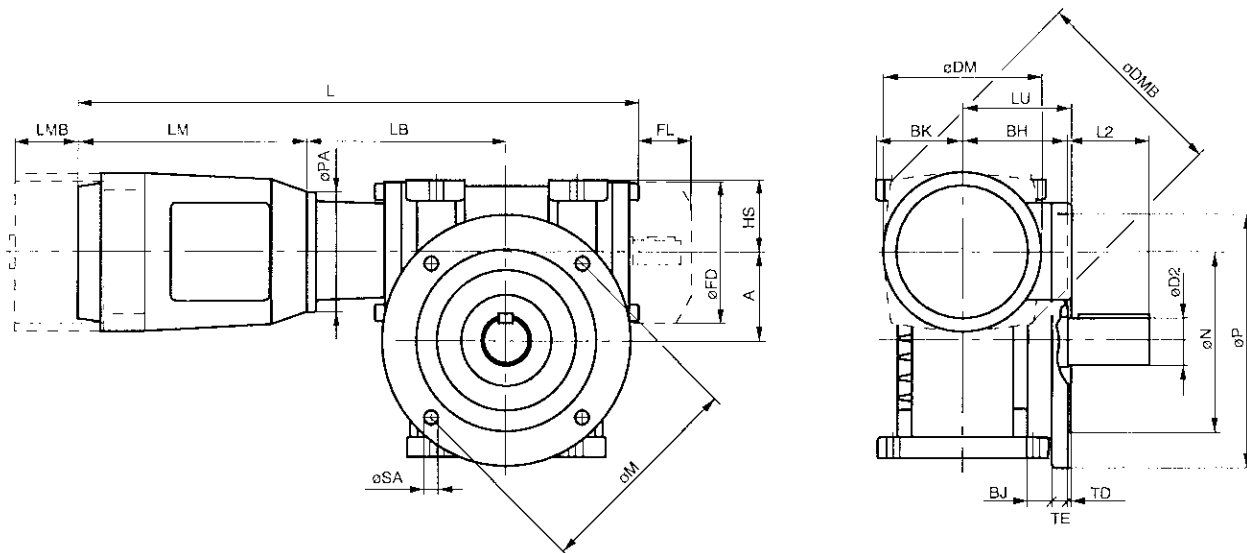

BS 88-112

Mounting position OH

Position of terminal box, see page 11

Shaft tolerance, see page 57

Shaft-dimensions		Fan		Motor dimensions					With brake motor		
D2	L2	FD	FL	DM	HM	LM	LU	PA-B14	PA-B5	DMB	LMB
20	36			120	125	183	85	90	140		
				140	140	210	100	105	160	185	73
				158	152	232	112	120	200	201	72
				178	161	245	121	140	200	220	75
				178	161	270	121	140	200	220	75
25	42			140	150	210	100	105	160	185	73
				158	162	232	112	120	200	201	72
				178	171	245	121	140	200	220	75
				178	171	270	121	140	200	220	75
30	58			140	163	210	100	105	160	185	73
				158	175	232	112	120	200	201	72
				178	184	245	121	140	200	220	75
				178	184	270	121	140	200	220	75
				198	204	298	141	160	250	255	106
35	58			158	183	232	112	120	200	201	72
				178	192	245	121	140	200	220	75
				178	192	270	121	140	200	220	75
				198	212	298	141	160	250	255	106
				221	231	312	160	160	250	278	109
45	82			158		232	112	120	200	201	72
				178		245	121	140	200	220	75
				178		270	121	140	200	220	75
				198		298	136	160	250	255	106
				221		312	156	160	250	278	109
				248		381	167		300	317	135
55	82			178		245	121	140	200	220	75
				178		270	121	140	200	220	75
				198		298	136	160	250	255	106
				198		298	136	160	250	255	106
				221		312	156	160	250	278	109
				221		312	156	160	250	278	109
				248		381	167		300	317	135
		310		486	210		300	375	170		

Worm geared motors BS 50/40 - BS112/63 Shaftmounted

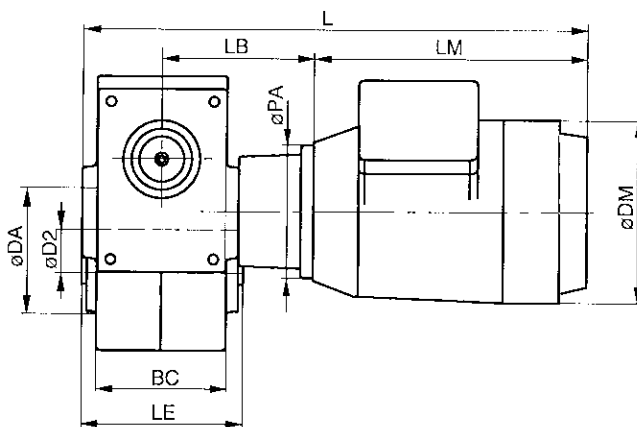
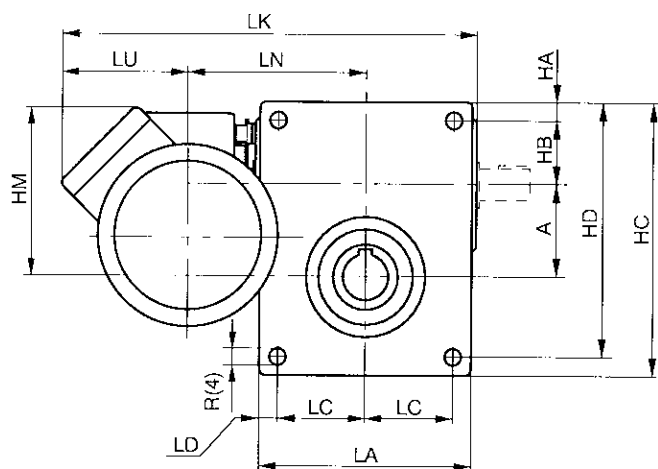

BS 50/40 - 71/40

Mounting position O, U -P7

Mountingsposition O -P7

Position of terminal box, see page 11

Shaft tolerance, see page 57

BS	Motor-size	Motor dimensions						Gear unit dimensions													
		L	B14 LK	LB	L	B5 LK	LB	A	BC	DA	HA	HB	HC	HD	HE	HH	HJ	LA	LC	LN	R
50/40	63	355	280	112	355	280	112											124	52	124	8.3
	71	387	295	118	388	295	118	50	78	68	10	38	155	145							
	80	420	307	128	420	307	128														
63/40	63	355	302	112	355	302	112											146	63	135	8.3
	71	387	317	118	388	317	118	63	82	80	10	43	183	173							
	80	420	329	128	420	329	128														
71/40	63	355	310	112	355	310	112											165	68.5	139	10.3
	71	387	325	118	388	325	118	71	101.4	92	14	49	209	195							
	80	420	337	128	420	337	128														
88/50	71	435	412	140	435	412	140														
	80	467	424	150	477	424	160														
	90 S	490	433	160	490	433	160	88						275	203	115				180	12.3
	90 L	515	433	160	515	433	160														
112/63	71	466	453	151	466	453	151														
	80	498	465	161	508	465	171														
	90 S	521	474	171	521	474	171	112						340	252	140				200	
	90 L	546	474	171	546	474	171														
	100	585	494	181.5	585	494	181.5														

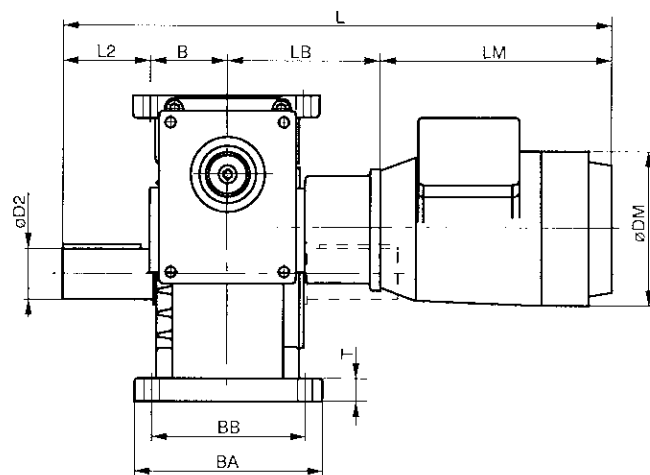
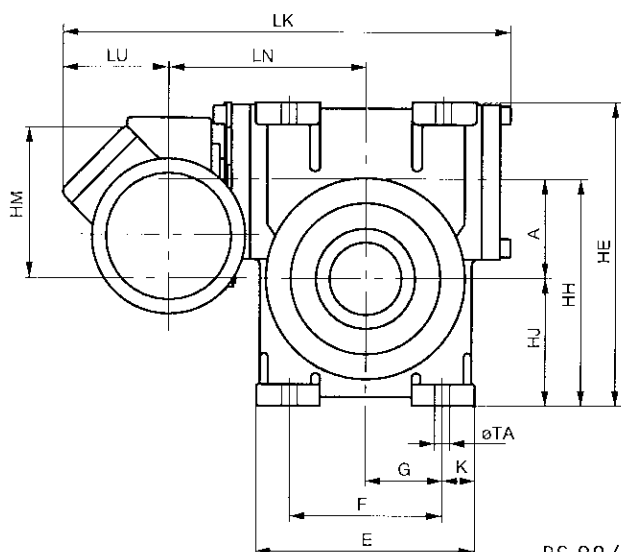

BS 88/50 - 112/63

Position of terminal box, see page 11
 Shaft tolerance, see page 57

BA	BB	E	F	G	K	T	TA	Shaft-dimensions		Motor-dimensions				
								D2	L2	DM	HM	LM	LU	PA
138	113	155	104	36.5	25.5	4	8.5	25	42	120	95	183	85	90
										140	110	210	100	105
										158	122	232	112	120
146	121	183	126	44.5	28.5	5	11	30	58	120	108	183	85	90
										140	123	210	100	105
										158	135	232	112	120
170	144	209	137	46.5	36	6	12.5	35	58	120	116	183	85	90
										140	131	210	100	105
										158	143	232	112	120
170	140	200	140	70	30	20	14	45	82	140	138	210	100	105
										158	150	232	112	120
										178	159	245	121	140
										178	159	270	121	140
210	175	250	175	87.5	37.5	23	18	55	82	140	149	210	100	105
										158	161	232	112	120
										178	170	245	121	140
										178	170	270	121	140
										198	190	298	141	160

Worm geared motors BS50/40 - BS 112/63 Footmounted

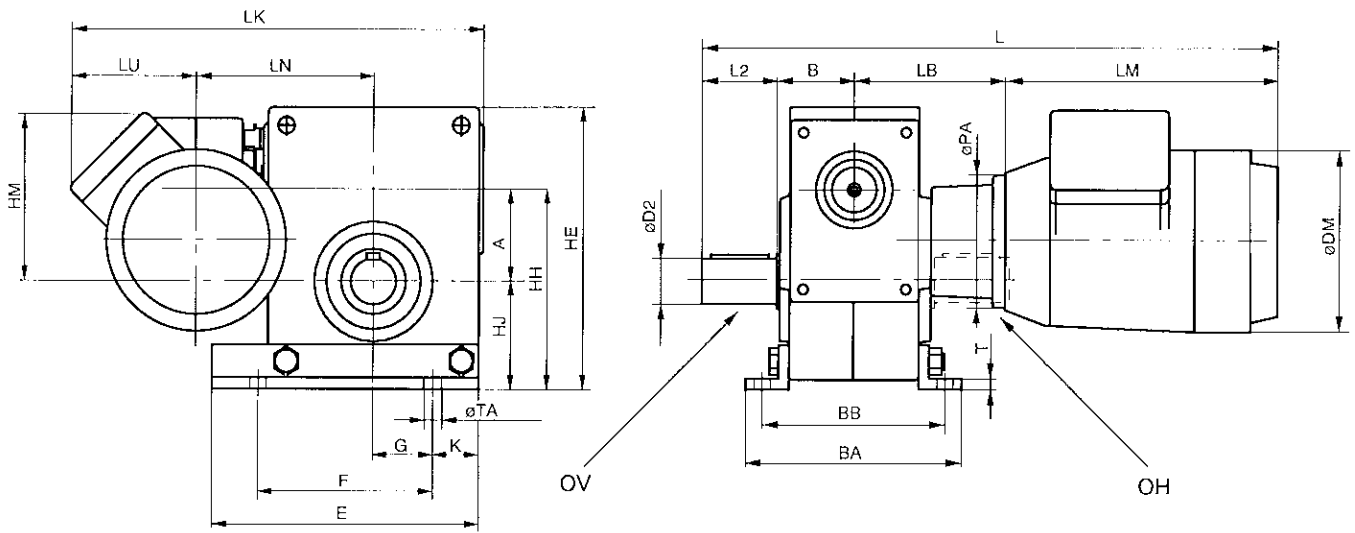

BS 50/40 - 71/40

Mounting position OV, OH, OO - P7

Mounting position OV - P7

Position of terminal box, see page 11

Shaft tolerance, see page 57

BS	Motor-size	Motor dimensions						Gear unit dimensions					
		L	B14 LK	LB	L	B5 LK	LB	A	B	HE	HH	HJ	LN
50/40	63	387	280	112	387	280	112						
	71	420	295	118	420	295	118	50	50	167	119	69	124
	80	452	307	128	452	307	128						
63/40	63	405	302	112	405	302	112						
	71	438	317	118	438	317	118	63	52	195	142	79	135
	80	470	329	128	470	329	128						
71/40	63	415.5	310	112	415.5	310	112						
	71	448.5	325	118	448.5	325	118	71	62.5	216.5	153.5	82.5	139
	80	480.5	337	128	480.5	337	128						
88/50	71	502	412	140	502	412	140						
	80	536	424	150	536	424	160						
	90 S	557	433	160	557	433	160	88	70	275	203	115	180
	90 L	582	433	160	582	433	160						
112/63	71	525	453	151	525	453	151						
	80	557	465	161	557	465	171						
	90 S	580	474	171	580	474	171	112	82	340	252	140	200
	90 L	605	474	171	605	474	171						
	100	643.5	494	181.5	643.5	494	181.5						

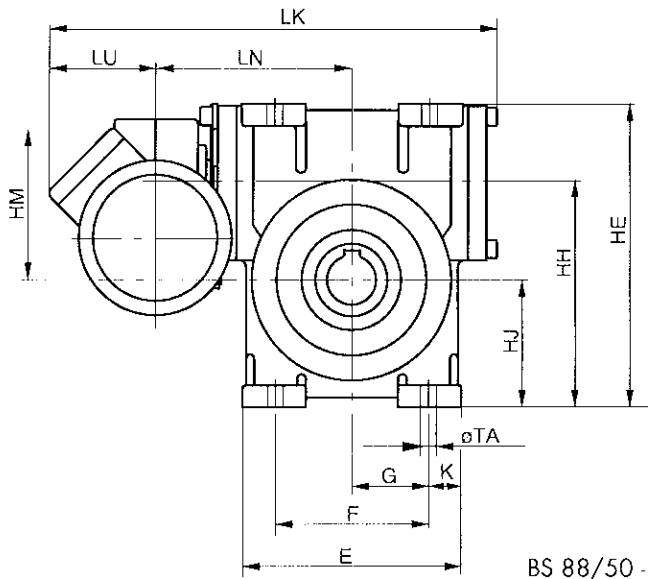

BS 88/50 - 112/63

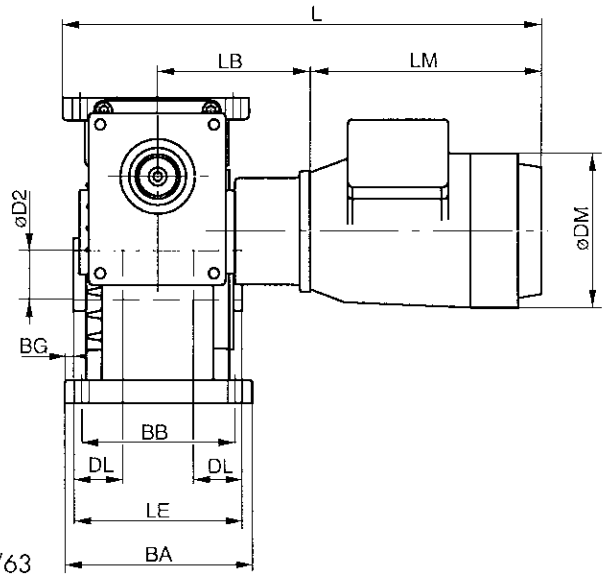

Mounting position 0,0 - P7

Position of terminal box, see page 11
 Shaft tolerance, see page 57

									Shaft-dimensions			Motor-dimensions				
BA	BB	BG	E	F	G	K	T	TA	D2	LE	DL	DM	HM	LM	LU	PA
									25	98		120	95	183	85	90
												140	110	210	100	105
												158	122	232	112	120
									30	101		120	108	183	85	90
												140	123	210	100	105
												158	135	232	112	120
									35	122		120	116	183	85	90
												140	131	210	100	105
												158	143	232	112	120
170	140	8	200	140	70	30	20	14	45	154	45	140	138	210	100	105
												158	150	232	112	120
												178	159	245	121	140
												178	159	270	121	140
210	175	18	250	175	87.5	37.5	23	18	55	174	50	140	149	210	100	105
												158	161	232	112	120
												178	170	245	121	140
												178	170	270	121	140
												198	190	298	141	160

BS 35 Power ratings

Ratio and code i	Input speed	Output speed	Input power	Output torque	Efficiency	Thermal rating 1)		Overhung load
	n ₁ rpm	n ₂ rpm	P ₁ kW	T ₂ Nm	η %	Shaft-mount kW	Foot-mount kW	F _{r2} N
10 A	2860	286	.80	19	71	.47	.63	1300
	1430	143	.49	26	79	.47	.60	1700
	930	93	.37	31	81	.37	.50	1900
	700	70	.31	35	81	.33	.42	2000
15 B	2860	191	.58	19	65	.36	.47	1600
	1430	95	.35	26	74	.34	.44	2000
	930	62	.27	31	74	.28	.36	2000
	700	47	.22	35	76	.24	.31	2000
20 C	2860	143	.51	19	55	.25	.34	1800
	1430	72	.30	26	64	.26	.33	2000
	930	46	.22	31	67	.21	.27	2000
	700	35	.18	34	69	.18	.24	2000
25 D	2860	114	.46	19	49	.22	.29	1900
	1430	57	.26	26	60	.22	.28	2000
	930	37	.19	31	62	.18	.24	2000
	700	28	.16	35	64	.16	.20	2000
30 E	2860	95	.38	19	49	.21	.29	2000
	1430	48	.22	26	60	.21	.26	2000
	930	31	.17	31	59	.17	.22	2000
	700	23	.14	36	61	.15	.19	2000
40 F	2860	72	.37	19	38	.16	.23	2000
	1430	36	.20	26	48	.16	.20	2000
	930	23	.15	31	51	.13	.17	2000
	700	18	.12	35	53	.12	.15	2000
50 G	2860	57	.34	19	33	.15	.20	2000
	1430	29	.18	26	42	.14	.18	2000
	930	19	.13	31	45	.12	.15	2000
	700	14	.11	35	48	.10	.13	2000

1) Gearbox with fan or motor motor with fan,
flange mounted on the gearbox.

BS 40 Power ratings

Ratio and code	Input speed n_1 rpm	Output speed n_2 rpm	Input power P_1 kW	Output torque T_2 Nm	Efficiency η %	Thermal rating 1)		Overhung load F_{r2} N
						Shaft-mount kW	Foot-mount kW	
6.67 (20/3) A	2860	429	1.9	37	85	.89	1.2	1300
	1430	214	1.3	50	86	1.1	1.3	1700
	930	139	.99	59	87	.84	1.0	1900
	730	109	.87	66	86	.73	.92	2000
10 (20/2) B	2860	286	1.5	43	83	.86	1.1	1600
	1430	143	1.0	57	85	1.0	1.2	2000
	930	93	.78	69	85	.79	.99	2000
	730	73	.68	76	85	.69	.86	2000
15 (30/2) C	2860	191	1.1	44	78	.65	.87	1900
	1430	95	.73	58	79	.75	.92	2000
	930	62	.56	70	80	.58	.73	2000
	730	49	.50	77	79	.51	.64	2000
20 (20/1) D	2860	143	.91	44	72	.53	.70	2000
	1430	72	.58	58	75	.60	.73	2000
	930	46	.45	70	75	.47	.58	2000
	730	36	.40	78	74	.41	.52	2000
24 (24/1)	2860	119	.80	44	69	.47	.62	2000
	1430	60	.51	58	71	.53	.65	2000
	930	39	.39	70	72	.41	.51	2000
	730	30	.35	78	71	.36	.45	2000
30 (30/1) F	2860	95	.69	44	64	.41	.53	2000
	1430	48	.44	59	67	.45	.54	2000
	930	31	.34	70	67	.35	.44	2000
	730	24	.30	78	66	.31	.39	2000
40 (40/1) G	2860	72	.57	43	56	.34	.44	2000
	1430	36	.37	58	59	.36	.44	2000
	930	23	.28	69	60	.28	.35	2000
	730	18	.25	76	58	.25	.31	2000
48 (48/1) H	2860	60	.52	44	52	.32	.41	2000
	1430	30	.32	58	56	.33	.40	2000
	930	19	.24	66	56	.26	.33	2000
	730	15	.21	71	55	.23	.29	2000
60 (60/1) I	2860	48	.45	42	46	.29	.37	2000
	1430	24	.26	52	49	.29	.35	2000
	930	16	.18	54	49	.23	.29	2000
	730	12	.15	56	47	.21	.26	2000
70 (70/1) J	2860	41	.39	40	43	.29	.36	2000
	1430	20	.21	44	44	.29	.35	2000
	930	13	.14	46	46	.23	.28	2000
	730	10	.11	47	44	.20	.25	2000
84 (84/1) K	2860	34	.32	31	34	.27	.33	2000
	1430	17	.16	33	36	.27	.32	2000
	930	11	.10	35	38	.21	.26	2000
	730	8.7	.09	36	37	.19	.23	2000

1) Gearbox with fan or motor motor with fan, flange mounted on the gearbox.

BS 50 Power ratings

Ratio and code	Input speed n_1 rpm	Output speed n_2 rpm	Input power P_1 kW	Output torque T_2 Nm	Efficiency η %	Thermal rating 1)		Overhung load F_{r2} N
						Shaft-mount kW	Foot-mount kW	
8 (24/3) A	2860	358	2.6	62	88	1.7	2.2	1900
	1430	179	1.7	83	88	1.7	2.1	2400
	930	116	1.4	99	88	1.3	1.6	2700
	730	91	1.2	110	88	1.1	1.4	2700
10.5 (21/2) B	2860	272	2.1	65	86	1.4	1.8	2200
	1430	136	1.4	87	87	1.4	1.7	2700
	930	89	1.1	103	85	1.1	1.4	2700
	730	70	.97	114	85	.94	1.2	2700
14 (28/2) C	2860	204	1.7	66	82	1.2	1.5	2500
	1430	102	1.1	88	84	1.2	1.5	2700
	930	66	.88	105	83	.91	1.1	2700
	730	52	.77	117	83	.78	.97	2700
21 (21/1) D	2860	136	1.2	66	76	.86	1.1	2700
	1430	68	.80	87	77	.84	1.0	2700
	930	44	.63	104	76	.64	.80	2700
	730	35	.56	116	75	.56	.69	2700
24 (24/1) E	2860	119	1.1	63	73	.74	.93	2700
	1430	60	.71	85	74	.72	.87	2700
	930	39	.57	102	72	.55	.69	2700
	730	30	.49	112	72	.48	.60	2700
32 (32/1) F	2860	89	.92	68	69	.69	.86	2700
	1430	45	.59	90	71	.65	.79	2700
	930	29	.47	108	69	.50	.62	2700
	730	23	.41	120	69	.43	.54	2700
37 (37/1) Fx	2860	77	.82	66	65	.59	.73	2700
	1430	39	.53	88	66	.56	.67	2700
	930	25	.43	106	64	.43	.53	2700
	730	20	.37	116	64	.37	.47	2700
42 (42/1) G	2860	68	.76	68	63	.57	.70	2700
	1430	34	.49	90	65	.54	.65	2700
	930	22	.40	109	63	.42	.51	2700
	730	17	.34	120	63	.36	.45	2700
54 (54/1) H	2860	53	.66	68	57	.49	.61	2700
	1430	26	.42	90	59	.46	.55	2700
	930	17	.34	109	57	.35	.43	2700
	730	14	.30	120	57	.31	.38	2700
64 (64/1) I	2860	45	.60	69	53	.46	.56	2700
	1430	22	.39	93	55	.42	.51	2700
	930	15	.28	100	53	.33	.40	2700
	730	11	.23	102	53	.29	.36	2700
80 (80/1) J	2860	36	.50	66	49	.44	.53	2700
	1430	18	.27	71	49	.40	.47	2700
	930	12	.19	75	47	.31	.38	2700
	730	9.1	.15	77	47	.27	.34	2700

1) Gearbox with fan or motor motor with fan, flange mounted on the gearbox.

BS 63 Power ratings

Ratio and code i	Input speed n ₁ rpm	Output speed n ₂ rpm	Input power P ₁ kW	Output torque T ₂ Nm	Efficiency η %	Thermal rating 1)		Overhung load F _{r2} N
						Shaft-mount kW	Foot-mount kW	
7.75 (31/4) A	2860	369	4.3	101	91	2.8	3.5	2100
	1430	185	2.9	134	90	2.6	3.2	2600
	930	120	2.3	162	90	2.0	2.4	2900
	730	94	2.0	178	89	1.7	2.1	3200
11 (33/3) B	2860	260	3.4	112	89	2.6	3.2	2400
	1430	130	2.3	149	88	2.3	2.8	3000
	930	85	1.8	178	88	1.7	2.1	3400
	730	66	1.6	197	88	1.5	1.8	3700
14 (28/2) C	2860	204	2.8	115	87	2.2	2.7	2700
	1430	102	1.9	154	87	2.0	2.4	3400
	930	66	1.3	160	86	1.5	1.8	4000
	730	52	1.0	160	85	1.2	1.6	4000
18 (36/2) D	2860	159	2.2	111	82	1.7	2.1	3100
	1430	79	1.5	149	83	1.5	1.8	3900
	930	52	1.2	178	83	1.1	1.4	4000
	730	41	1.0	196	81	.97	1.2	4000
24.5 (49/2) E	2860	117	1.8	119	80	1.5	1.9	3500
	1430	58	1.2	160	81	1.4	1.6	4000
	930	38	.81	162	79	1.0	1.3	4000
	730	30	.64	162	79	.87	1.1	4000
29 (29/1) F	2860	99	1.6	117	77	1.3	1.6	3800
	1430	49	1.0	156	77	1.1	1.4	4000
	930	32	.82	188	77	.86	1.1	4000
	730	25	.67	192	75	.74	.92	4000
37 (37/1) F _x	2860	77	1.3	109	69	.92	1.1	4000
	1430	39	.85	147	70	.81	.97	4000
	930	25	.67	175	68	.62	.77	4000
	730	20	.60	194	67	.54	.67	4000
43 (43/1) G	2860	67	1.2	121	70	1.0	1.2	4000
	1430	33	.78	160	71	.89	1.1	4000
	930	22	.53	166	70	.67	.82	4000
	730	17	.43	165	68	.57	.71	4000
51 (51/1) H	2860	56	1.1	121	67	.89	1.1	4000
	1430	28	.69	160	67	.78	.93	4000
	930	18	.53	184	66	.59	.73	4000
	730	14	.42	183	65	.51	.63	4000
57 (57/1) I	2860	50	.98	121	64	.83	1.0	4000
	1430	25	.64	160	65	.73	.87	4000
	930	16	.51	193	64	.55	.68	4000
	730	13	.41	193	62	.47	.59	4000
73 (73/1) J	2860	39	.85	121	58	.72	.87	4000
	1430	20	.56	162	59	.61	.74	4000
	930	13	.40	174	58	.47	.57	4000
	730	10	.33	179	56	.41	.51	4000
104 (104/1) K	2860	28	.56	92	47	.61	.73	4000
	1430	14	.31	100	46	.52	.62	4000
	930	8.9	.21	105	47	.40	.49	4000
	730	7	.17	107	45	.35	.43	4000

1) Gearbox with fan or motor with fan, flange mounted on the gearbox.

BS 71 Power ratings

Ratio and code	Input speed n ₁ rpm	Output speed n ₂ rpm	Input power P ₁ kW	Output torque T ₂ Nm	Efficiency η %	Thermal rating 1)		Overhung load F _{r2} N
						Shaft-mount kW	Foot-mount kW	
7.5 (30/4) A	2860	381	6.5	151	92	3.2	4.4	2200
	1430	191	4.3	201	92	3.6	3.8	2700
	930	124	3.4	242	91	2.4	2.9	3100
	730	97	3.0	267	91	2.0	2.5	3300
9.33 (28/3) B	2860	307	5.7	163	91	3.4	4.2	2400
	1430	153	3.8	218	91	3.1	3.7	3000
	930	100	3.0	260	90	2.3	2.8	3400
	730	78	2.6	288	89	1.9	2.4	3600
12 (36/3) C	2860	238	4.5	160	89	2.7	3.3	2900
	1430	119	3.0	215	88	2.4	2.9	3500
	930	78	2.3	255	88	1.8	2.2	4000
	730	61	2.0	282	87	1.5	1.9	4300
16 (32/2) D	2860	179	3.6	169	87	2.3	2.8	3300
	1430	89	2.4	224	87	2.0	2.5	4000
	930	58	1.9	269	85	1.5	1.9	4600
	730	46	1.7	297	85	1.3	1.6	5000
21 (42/2) E	2860	136	2.9	173	84	2.0	2.4	3700
	1430	68	1.9	230	84	1.7	2.0	4600
	930	44	1.5	276	83	1.3	1.6	5000
	730	35	1.4	305	82	1.1	1.4	5000
28 (28/1) F	2860	102	2.2	168	80	1.5	1.8	4200
	1430	51	1.5	225	79	1.3	1.5	5000
	930	33	1.2	267	77	.97	1.2	5000
	730	26	1.0	298	77	.83	1.0	5000
37 (37/1) G	2860	77	1.9	178	76	1.3	1.6	4700
	1430	39	1.3	238	76	1.1	1.3	5000
	930	25	1.0	283	74	.84	1.0	5000
	730	20	.89	315	73	.72	.89	5000
48 (48/1) H	2860	60	1.5	175	71	1.1	1.3	5000
	1430	30	1.0	234	71	.93	1.1	5000
	930	19	.82	281	69	.70	.86	5000
	730	15	.72	310	68	.60	.75	5000
63 (63/1) I	2860	45	1.3	175	66	.89	1.1	5000
	1430	23	.85	234	65	.76	.91	5000
	930	15	.69	281	63	.58	.71	5000
	730	12	.61	310	61	.51	.63	5000
82 (82/1) J	2860	35	1.1	178	60	.77	.92	5000
	1430	17	.62	201	58	.66	.79	5000
	930	11	.45	211	56	.50	.61	5000
	730	8.9	.37	216	54	.44	.54	5000
100 (100/1) K	2860	29	.77	143	56	.76	.91	5000
	1430	14	.42	154	54	.64	.77	5000
	930	9.3	.30	162	49	.49	.60	5000
	730	7.3	.25	166	43	.43	.53	5000

1) Gearbox with fan or motor with fan, flange mounted on the gearbox.

BS 88 Power ratings

Ratio and code	Input speed n ₁ rpm	Output speed n ₂ rpm	Input power P ₁ kW	Output torque T ₂ Nm	Efficiency η %	Thermal rating 1)		Overhung load F _{r2} N
						Shaft-mount kW	Foot-mount kW	
7.25 (29/4) A	2860	394	15.6	358	94	9.3	11.3	4000
	1430	197	9.9	449	94	6.7	8.4	5000
	930	128	7.5	518	93	4.5	5.9	5800
	730	101	6.4	560	92	3.6	4.9	6300
11.75 (47/4) B	2860	243	10.1	368	93	7.6	9.3	5100
	1430	122	6.8	490	91	5.4	6.8	6300
	930	79	5.1	564	90	3.6	4.8	7300
	730	62	4.4	611	90	2.9	4.0	7900
15.67 (47/3) C	2860	183	7.7	364	90	6.1	7.4	6000
	1430	91	5.1	481	89	4.3	5.4	7400
	930	59	3.9	562	88	2.9	3.8	8500
	730	47	3.4	610	87	2.3	3.2	9200
19.5 (39/2) D	2860	147	6.6	377	88	4.7	5.7	6600
	1430	73	4.4	496	87	3.3	4.2	8200
	930	48	3.4	578	85	2.3	3.0	9400
	730	37	2.9	627	84	1.8	2.5	10000
23.5 (47/2) E	2860	122	5.4	367	86	4.4	5.3	7200
	1430	61	3.6	479	85	3.1	3.9	9000
	930	40	2.7	556	84	2.1	2.7	10000
	730	31	2.3	602	83	1.7	2.3	10000
29 (29/1) F	2860	99	5.2	413	82	3.0	3.7	8800
	1430	49	3.3	524	80	2.2	2.7	10000
	930	32	2.6	604	78	1.5	2.0	10000
	730	25	2.2	654	77	1.2	1.7	10000
39 (39/1) G	2860	73	3.9	406	79	2.7	3.2	9600
	1430	37	2.6	525	77	1.9	2.4	10000
	930	24	2.0	606	74	1.3	1.7	10000
	730	19	1.7	654	73	1.1	1.5	10000
47 (47/1) H	2860	61	3.2	396	77	2.5	3.0	10000
	1430	30	2.1	508	75	1.8	2.2	10000
	930	20	1.7	585	73	1.2	1.6	10000
	730	16	1.4	630	72	.99	1.3	10000
58 (58/1) J	2860	49	2.7	383	74	2.3	2.8	10000
	1430	25	1.7	488	72	1.7	2.1	10000
	930	16	1.3	560	69	1.1	1.5	10000
	730	13	1.2	602	68	.92	1.2	10000
71 (71/1) K	2860	40	2.1	343	69	1.9	2.3	10000
	1430	20	1.4	437	67	1.4	1.7	10000
	930	13	1.1	492	64	.95	1.2	10000
	730	10	.86	505	63	.78	1.0	10000
82 (82/1) L	2860	35	1.8	341	68	1.9	2.3	10000
	1430	17	1.1	390	66	1.4	1.7	10000
	930	11	.77	409	62	.94	1.2	10000
	730	8.9	.64	420	61	.77	1.0	10000
106 (106/1) M	2860	27	1.2	248	59	1.6	2.0	10000
	1430	13	.66	269	57	1.2	1.5	10000
	930	8.8	.47	281	55	.81	1.1	10000
	730	6.9	.39	289	54	.67	.90	10000

1) Gearbox with fan or motor with fan, flange mounted on the gearbox.

BS 112 Power ratings

Ratio and code	Input speed	Output speed	Input power	Output torque	Efficiency	Thermal rating 1)		Overhung load
						Shaft-mount	Foot-mount	
i	n ₁ rpm	n ₂ rpm	P ₁ kW	T ₂ Nm	η %	kW	kW	F _{r2} N
7 (28/4) A	2860	409	27.3	607	95	20.0	24.1	6200
	1430	204	18.3	806	94	13.9	17.2	7600
	930	133	13.8	929	93	9.3	12.2	8900
	730	104	11.7	1006	93	7.4	10.0	9500
11.5 (46/4) B	2860	249	19.7	709	93	17.5	21.0	7500
	1430	124	12.5	891	93	11.8	14.6	9500
	930	81	9.4	1026	92	7.8	10.2	10900
	730	63	8.1	1111	91	6.2	8.4	11800
15.3 (46/3) C	2860	187	14.9	705	92	14.0	16.8	8900
	1430	93	10.0	936	91	9.4	11.6	11000
	930	61	7.6	1078	90	6.3	8.2	12700
	730	48	6.5	1167	90	5.0	6.7	13800
19.5 (39/2) D	2860	147	11.8	691	89	10.6	12.7	10300
	1430	73	7.9	912	88	7.2	9.0	12800
	930	48	6.0	1064	87	4.8	6.3	14800
	730	37	5.2	1155	87	3.8	5.2	15000
23 (46/2) E	2860	124	10.3	708	89	10.0	11.9	10900
	1430	62	6.8	928	88	6.7	8.3	13600
	930	40	5.3	1080	86	4.5	5.9	15000
	730	32	4.5	1171	85	3.6	4.8	15000
28 (28/1) F	2860	102	8.6	679	84	6.5	7.7	12100
	1430	51	5.7	893	83	4.5	5.5	15000
	930	33	4.5	1041	80	3.1	4.0	15000
	730	26	3.9	1129	79	2.5	3.3	15000
39 (39/1) G	2860	73	6.9	741	82	5.9	7.1	13700
	1430	37	4.6	960	80	4.1	5.0	15000
	930	24	3.5	1111	78	2.8	3.6	15000
	730	19	3.0	1200	77	2.2	3.0	15000
46 (46/1) H	2860	62	6.1	755	81	5.6	6.7	14600
	1430	31	4.0	974	79	3.8	4.7	15000
	930	20	2.1	1124	77	2.6	3.4	15000
	730	16	1.8	1212	75	2.1	2.8	15000
63 (63/1) J	2860	45	4.2	684	77	4.8	5.8	15000
	1430	23	2.7	874	75	3.3	4.1	15000
	930	15	3.1	1003	73	2.2	2.9	15000
	730	12	2.7	1065	71	1.8	2.4	15000
76 (76/1) K	2860	38	3.5	654	73	4.4	5.2	15000
	1430	19	2.3	831	71	3.0	3.7	15000
	930	12	1.6	861	69	2.0	2.6	15000
	730	9.6	1.3	858	68	1.6	2.2	15000
95 (95/1) L	2860	30	2.7	587	69	3.7	4.4	15000
	1430	15	1.5	636	66	2.5	3.1	15000
	930	9.8	1.1	667	63	1.7	2.2	15000
	730	7.7	.89	684	62	1.4	1.9	15000
108 (108/1) M	2860	26	2.1	484	64	3.4	4.0	15000
	1430	13	1.2	524	61	2.3	2.9	15000
	930	8.6	.83	549	59	1.6	1.7	15000
	730	6.8	.69	563	58	1.3	1.7	15000

1) Gearbox with fan or motor motor with fan, flange mounted on the gearbox.

Double worm gears Power ratings

Ratio and code	Input speed	Output speed	Input power	Output torque	Efficiency	Thermal rating 1)		Overhung load
						Shaft- mount	Foot- mount	
Code i	n ₁ rpm	n ₂ rpm	P ₁ kW	T ₂ Nm	η %	kW	kW	F _{r2} N
BS 50/40								
EA 160	1430	8.9	.31	150	45	.30	.38	2700
EB 240	1430	6	.24	150	39	.27	.34	2700
EC 360	1430	4	.20	150	32	.25	.31	2700
ED 480	1430	3	.17	150	28	.23	.30	2700
EE 576	1430	2.5	.16	150	25	.23	.29	2700
EF 720	1430	2	.14	150	22	.22	.28	2700
EG 960	1430	1.5	.13	150	18	.21	.27	2700
EH 1152	1430	1.2	.12	150	16	.21	.27	2700
EI 1440	1430	1	.12	150	13	.20	.26	2700
EJ 1680	1430	0.9	.12	150	12	.20	.26	2700
EK 2016	1430	0.7	.11	150	10	.20	.26	2700
BS 63/4 0								
FA 193	1430	7.4	.40	250	48	.44	.56	4000
FB 290	1430	4.9	.31	250	42	.40	.51	4000
FC 435	1430	3.3	.25	250	34	.36	.46	4000
FD 580	1430	2.5	.23	250	29	.35	.44	4000
FE 696	1430	2.1	.21	250	26	.33	.42	4000
FF 870	1430	1.6	.18	250	23	.32	.41	4000
FG 1160	1430	1.2	.17	250	19	.31	.39	4000
FH 1392	1430	1	.16	250	16	.30	.39	4000
FI 1740	1430	0.8	.15	250	14	.29	.35	4000
FJ 2030	1430	0.7	.15	250	12	.29	.35	4000
FK 2436	1430	0.6	.14	250	11	.27	.32	4000
BS 71/4 0								
FA 187	1430	7.7	.58	400	55	.50	.63	5000
FB 280	1430	5.1	.43	400	50	.44	.56	5000
FC 420	1430	3.4	.33	400	42	.40	.51	5000
FD 560	1430	2.6	.28	400	38	.38	.48	5000
FE 672	1430	2.1	.26	400	34	.37	.47	5000
FF 840	1430	1.7	.23	400	31	.35	.45	5000
FG 1120	1430	1.3	.20	400	26	.34	.43	5000
FH 1344	1430	1.1	.18	400	24	.33	.40	5000
FI 1680	1430	0.9	.17	400	21	.29	.35	5000
FJ 1960	1430	0.7	.16	400	19	.29	.35	5000
FK 2352	1430	0.6	.15	400	17	.27	.32	5000
BS 88/5 0								
FA 232	1430	6.2	.92	800	56	.61	.89	10000
FB 304	1430	4.7	.75	800	52	.57	.82	10000
FC 406	1430	3.5	.62	800	47	.53	.77	10000
FD 609	1430	2.3	.47	800	41	.48	.69	10000
FE 696	1430	2.1	.45	800	38	.47	.68	10000
FF 928	1430	1.5	.37	800	34	.44	.64	10000
FFX 1073	1430	1.3	.35	800	32	.43	.63	10000
FG 1218	1430	1.2	.32	800	30	.43	.62	10000
FH 1566	1430	0.9	.29	800	26	.42	.55	10000
FI 1856	1430	0.8	.27	800	24	.41	.51	10000
FJ 2320	1430	0.6	.23	800	22	.40	.47	10000
BS 112/63								
FA 217	1430	6.6	1.6	1400	61	1.2	1.7	15000
FB 308	1430	4.6	1.2	1400	56	1.1	1.6	15000
FC 392	1430	3.6	1.0	1400	53	1.0	1.5	15000
FD 504	1430	2.8	.86	1400	48	.95	1.4	15000
FE 686	1430	2.1	.68	1400	44	.89	1.3	15000
FF 812	1430	1.8	.62	1400	41	.85	1.2	15000
FFX 1036	1430	1.4	.56	1400	36	.81	.97	15000
FG 1204	1430	1.2	.49	1400	35	.79	1.1	15000
FH 1428	1430	1.0	.45	1400	32	.77	.93	15000
FI 1596	1430	0.9	.42	1400	30	.73	.87	15000
FJ 2044	1430	0.7	.37	1400	27	.61	.74	15000
FK 2912	1430	0.5	.31	1400	22	.52	.62	15000

1) Gearbox with fan or motor motor with fan,
flange mounted on the gearbox.

Standard execution BS40-71

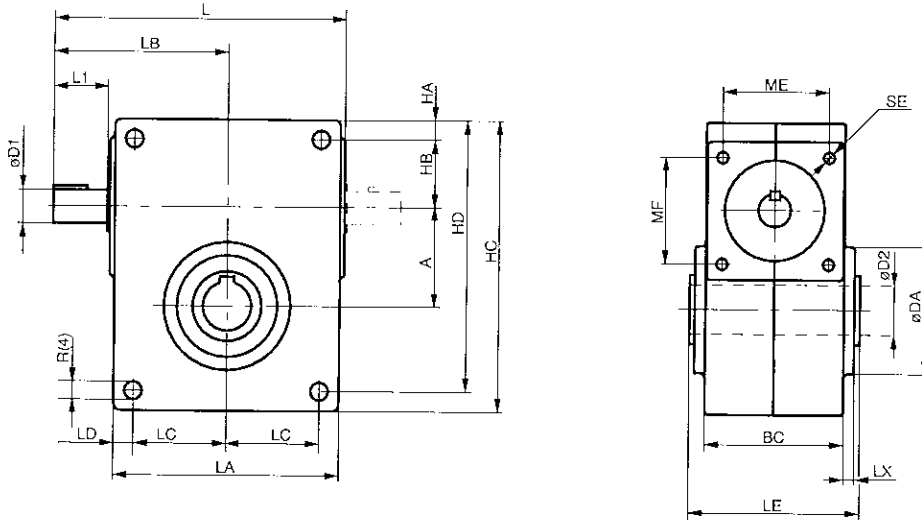

Mounting position O, hollow shaft

BS	A	BC	D1	D2	DA	HA	HB	HC	HD	L	L1	LA	LB	LC	LD	LE	LX	ME	MF	ϕR	SE	Kgs
40	40	73	14	20	58	10	36	140	130	146	25	100	86	40	10	92	8.5	46	46	8.1	M8x12	3.0
50	50	78	19	25	68	10	38	155	145	179	35	124	108	52	10	98	8	56.6	56.6	8.3	M8x12	4.8
63	63	82	19	30	80	10	43	183	173	200.5	35	146	118.5	63	10	101	7	56.6	56.6	10.3	M8x12	6.5
71	71	101.4	24	35	92	14	49	209	195	214	40	165	128	68.5	14	122	7.3	76.4	76.4	12.5	M8x14	9.6

Underdriven worm gear with feet and output shaft

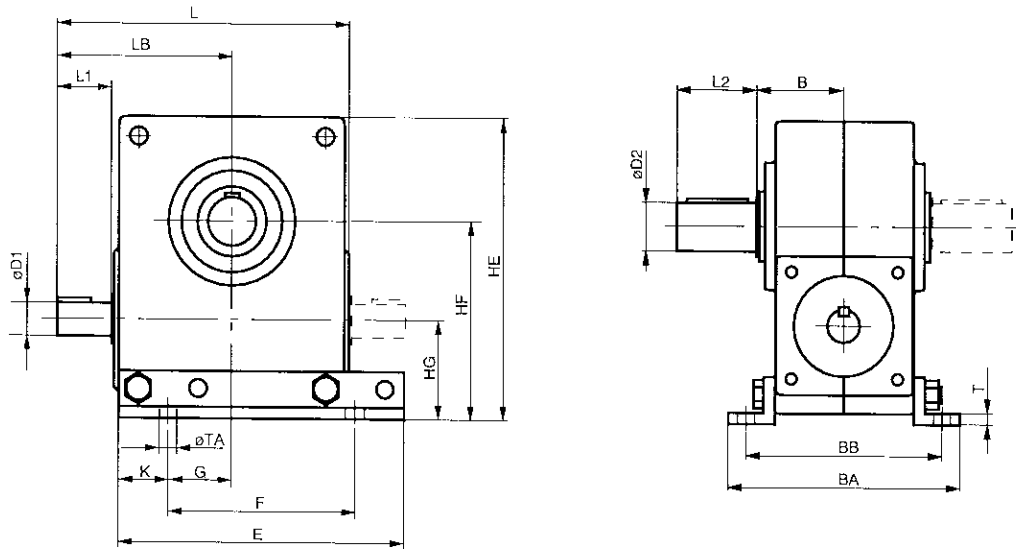

Mounting position UV, UH, UD

Mounting position UV

BS	B	BA	BB	D1	D2	E	F	G	HE	HF	HG	K	L	L1	L2	LB	T	TA	Kgs
40	47	133	108	14	20	140	80	20	152	98	58	30	146	25	36	86	5	8.5	3.0
50	50	138	113	19	25	155	104	36.5	167	110	60	25.5	179	35	42	108	5	8.5	4.8
63	52	146	121	19	30	183	126	44.5	195	128	65	28.5	200.5	35	58	118.5	7	10.5	6.5
71	62.5	169.4	143.4	24	35	209	137	46.5	216.5	141.5	70.5	36	214	40	58	128	8	12.5	9.6

Shaft tolerance, see page 57

Overdriven worm gear with feet and output shaft

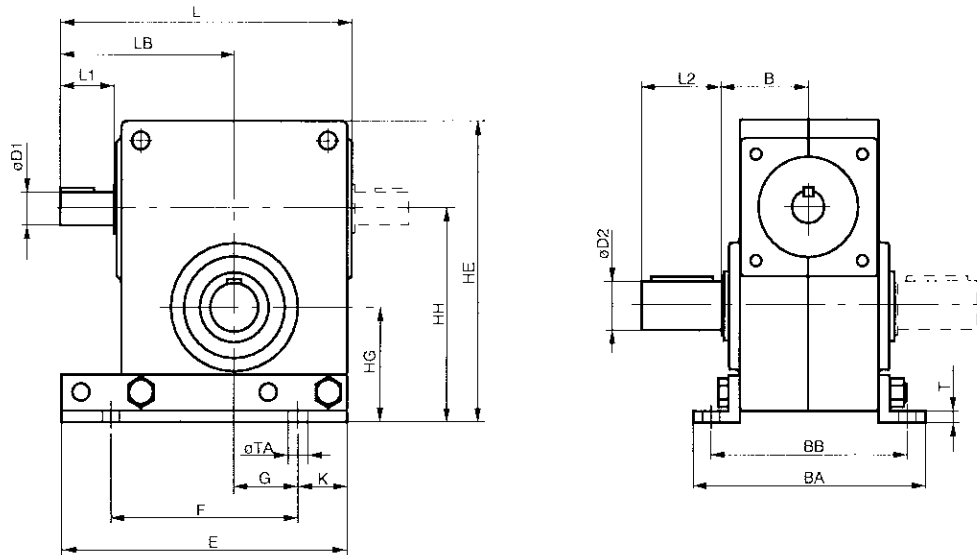

Mounting position OV, OH, OD

Mounting position OV

BS	B	BA	BB	D1	D2	E	F	G	HE	HH	HG	K	L	L1	L2	LB	T	TA	Kgs
40	47	133	108	14	20	140	80	20	152	106	66	30	146	25	36	86	5	8.5	3.0
50	50	138	113	19	25	155	104	36.5	167	119	69	25.5	179	35	42	108	5	8.5	4.8
63	52	146	121	19	30	183	126	44.5	195	142	79	28.5	200.5	35	58	118.5	7	10.5	6.5
71	62.5	169.4	143.4	24	35	209	137	46.5	216.5	153.5	82.5	36	214	40	58	128	8	12.5	9.6

Worm gear with vertical worm screw, feet and output shaft

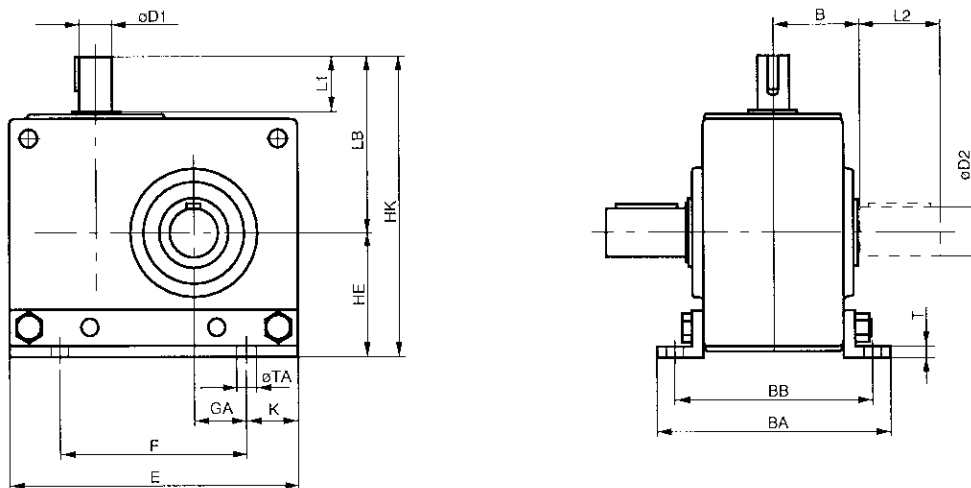

Mounting position VV, VH, VD

Mounting position VV

BS	B	BA	BB	D1	D2	E	F	GA	HE	HK	K	L1	L2	LB	T	TA	Kgs
40	47	133	108	14	20	140	80	24	62	148	30	25	36	86	5	8.5	3.9
50	50	138	113	19	25	155	104	31.5	74	182	25.5	35	42	108	5	8.5	6.1
63	52	146	121	19	30	183	126	38.5	85	203.5	28.5	35	58	118.5	7	10.5	8.3
71	62.5	169.4	143.4	24	35	209	137	39	90	218	36	40	58	128	8	12.5	12.0

Shaft tolerance, see page 57

Worm gear with horizontal input shaft and feet

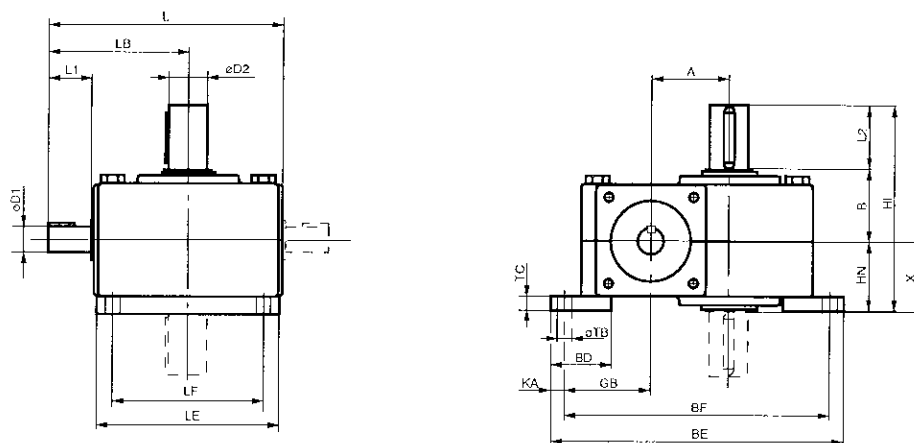

Mounting position HU, HN, HD. Also state position of input shaft A or B.

Mounting position HU-B

BS	A	B	BD	BE	BF	D1	D2	GB	HI	HN	KA	L	L1	L2	LB	LE	LF	TB	TC	X	Kgs
40	40	47	40	181	162	14	20	57	131.5	48.5	9.5	146	25	36	86	100	80	9	12	49	4.1
50	50	50	40	196	177	19	25	59	143	51	9.5	179	35	42	108	124	104	9	12	52	6.4
63	63	52	45	233	213	19	30	68	163	53	10	200.5	35	58	118.5	146	126	11	12	54	8.7
71	71	62.5	55	266	241	24	35	79	186.5	66	12.5	214	40	58	128	165	137	12.5	15	64.5	12.7

Standard execution with motorflange

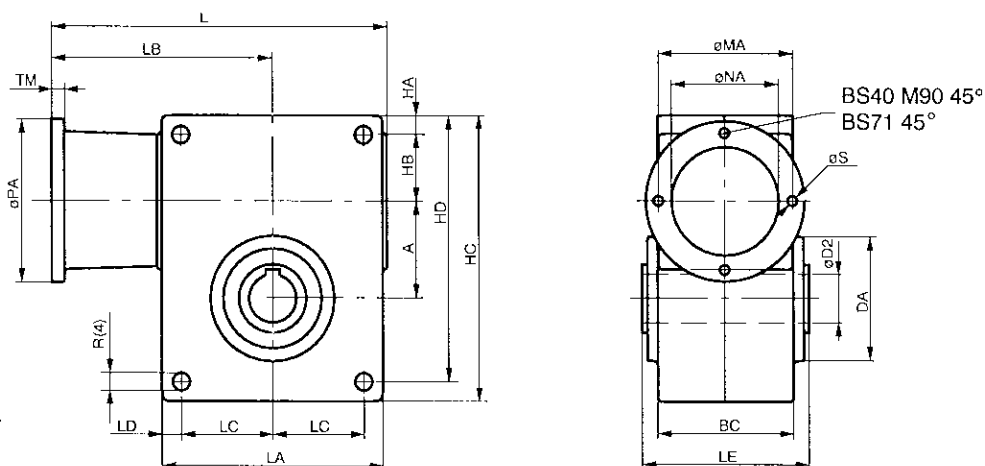

Mounting position O- or U-hollow shaft

Size	Motor-size	Flange type	A	BC	D2	DA	HA	HB	HC	HD	L	LA	LB	LC	LD	LE	MA	NA	PA	øR	S	TM	Kgs
40	63	B14									172		112			75	60	92		6	8	3.6	
	71	B14	40	73	20	58	10	36	140	130	178	100	118	40	10	92	85	70	102	8.3	7	9	3.6
	80	B14									188		128			100	80	118		7	10	3.6	
	90	B14									198		138			115	95	140		9	12	3.6	
50	71	B14									211		140			85	70	108		7	10	5.5	
	80	B14	50	78	25	68	10	38	155	145	221	124	150	52	10	98	100	80	118	8.3	7	10	5.7
	90	B14									231		160			115	95	140		9	12	5.9	
63	71	B14									233		151			85	70	108		7	10	7.2	
	80	B14	63	82	30	80	10	43	183	173	243	146	161	63	10	101	100	80	118	10.3	7	10	7.4
	90	B14									253		171			115	95	140		9	12	7.6	
	100	B14									263.5		181.5			130	110	160		9	12	7.8	
71	80	B14									263		177			100	80	118		7	10	10.6	
	90	B14	71	104.5	35	92	14	49	209	195	273	165	187	68.5	14	122	115	95	140	12.3	9	12	10.8
	100/112	B14									283.5		197.5			130	110	160		9	12	11.0	

Shaft tolerance, see page 57

Underdriven worm gear with feet, output shaft and motorflange

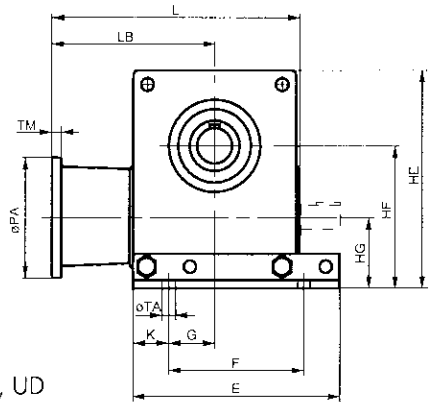

Mounting position UV, UH, UD

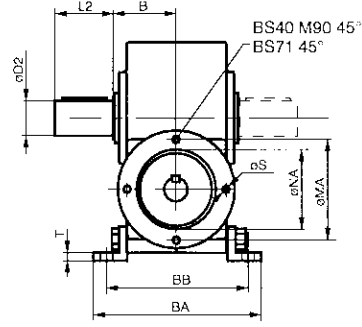

Mounting position UV

Size	Motor-size	Flange type	B	BA	BB	D2	E	F	G	HE	HF	HG	K	L	L2	LB	MA	NA	PA	TA	TM	S	T
40	63	B14												172		112	75	60	92		8	6	
	71	B14	47	133	108	20	140	80	20	152	98	58	30	178	36	118	85	70	102	8.5	9	7	5
	80	B14												188		128	100	80	118		10	7	
	90	B14												198		138	115	95	140		10	9	
50	71	B14												211		140	85	70	108		10	7	
	80	B14	50	138	113	25	155	104	36.5	167	110	60	25.5	221	42	150	100	80	118	8.5	10	7	5
	90	B14												231		160	115	95	140		12	9	
63	71	B14												233		151	85	70	108		10	7	
	80	B14	52	146	121	30	183	126	44.5	195	128	65	28.5	243	58	161	100	80	118	10.5	10	7	7
	90	B14												253		171	115	95	140		12	9	
	100	B14												263.5		181.5	130	110	160		12	9	
71	80	B14												263		177	100	80	118		10	7	
	90	B14	62.5	169.4	143.4	35	209	137	46.5	217	142	71	36	273	58	187	115	95	140	12.5	12	9	8
	100/112	B14												283.5		197.5	130	110	160		12	9	

Overdriven worm gear with feet, output shaft and motorflange

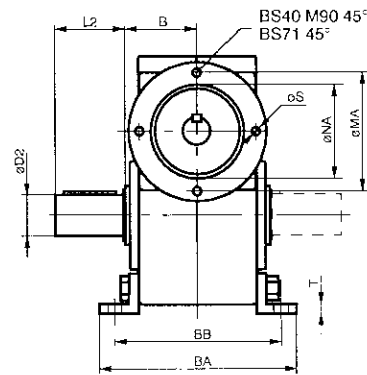
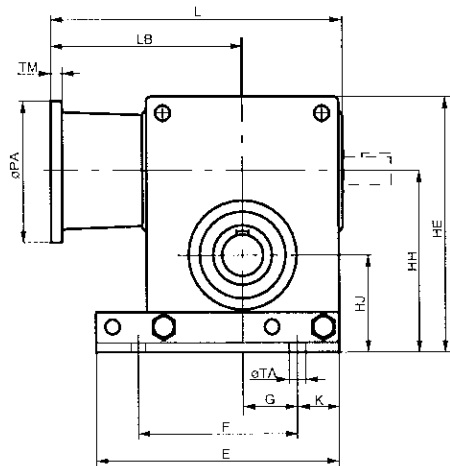

Mounting position OV

Size	Motor-size	Flange type	B	BA	BB	D2	E	F	G	HE	HH	HJ	K	L	L2	LB	MA	NA	PA	S	T	TA	TM
40	63	B14												172		112	75	60	92	6			8
	71	B14	47	133	108	20	140	80	20	152	106	66	30	178	36	118	85	70	102	7	5	8.5	9
	80	B14												188		128	100	80	118	7		10	
	90	B14												198		138	115	95	140	9		10	
50	71	B14												211		140	85	70	108	7		10	
	80	B14	50	138	113	25	155	104	36.5	167	110	60	25.5	221	42	150	100	80	118	7	5	8.5	10
	90	B14												231		160	115	95	140	9		12	
63	71	B14												233		151	85	70	108	7		10	
	80	B14	52	146	121	30	183	126	44.5	195	142	79	28.5	243	58	161	100	80	118	7	5	10.5	12
	90	B14												253		171	115	95	140	9		12	
	100	B14												263.5		181.5	130	110	160	9		12	
71	80	B14												263		177	100	80	118	7		10	
	90	B14	62.5	169.4	143.4	35	209	137	46.5	216.5	153.5	82.5	36	273	58	187	115	95	140	9	8	12.5	12
	100/112	B14												283.5		197.5	130	110	160	9		12	

Shaft tolerance, see page 57

Worm gear with vertical worm screw, feet, output shaft and motorflange

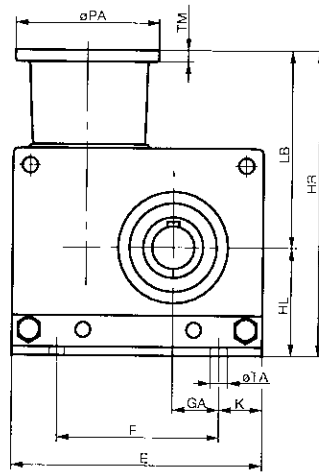

Mounting position VV, VH, VD

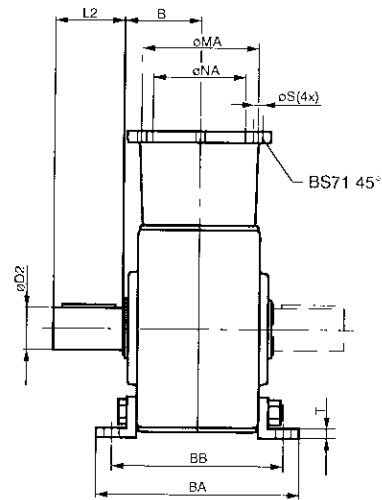

Mounting position VV

Size	Motor-size	Flange type	B	BA	BB	D2	E	F	GA	HR	HL	K	L2	LB	MA	NA	PA	S	T	TA	TM	Vikt
40	63	B14								174				112	75	60	92	6			8	4.5
	71	B14	47	133	108	20	140	80	24	180	62	30	36	118	85	70	102	7	5	8.5	9	4.5
	80	B14								190				128	100	80	118	7			10	4.5
	90	B14								200				138	115	95	140	9			10	4.5
	71	B14								214				140	85	70	108	7			10	6.8
50	80	B14	50	138	113	25	155	104	31.5	224	74	25.5	42	150	100	80	118	7	5	8.5	10	7.0
	90	B14								234				160	115	95	140	9			12	7.2
	71	B14								236				151	85	70	108				10	9.0
63	80	B14	52	146	121	30	183	126	38.5	246	85	28.5	58	161	100	80	118	7		10.5	10	9.2
	90	B14								256				171	115	95	140	9	7		12	9.4
	100	B14								266.5				181.5	130	110	160	9			12	9.6
71	80	B14								267				177	100	80	118	7			10	13.0
	90	B14	62.5	169.4	143.4	35	209	137	39	277	90	36	58	187	115	95	140	9	8	12.5	12	13.2
	100/112	B14								287.5				197.5	130	110	160	9			12	13.4

Motorflange type B5

Size	Motor size	LB	MA	NA	PA	S	TM
BS 40	63	112	115	95	140	9	9
	71	118	130	110	160	9	9
	80	128	165	130	200	11.5	10
	90	138	165	130	200	11.5	10
BS 50	71	140	130	110	160	9	10
	80	160	165	130	200	11.5	12
	90	160	165	130	200	11.5	12
BS 63	71	151	130	110	160	9	10
	80	171	165	130	200	11.5	12
	90	171	165	130	200	11.5	12
	100	181.5	215	180	250	14	12
BS 71	80	187	165	130	200	11.5	12
	90	187	165	130	200	11.5	12
	100/112	197.5	215	180	250	14	12

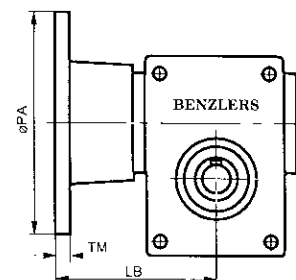
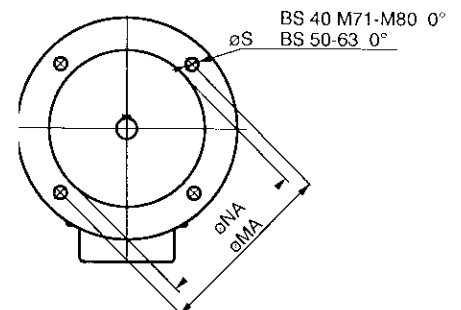

BS 88-112 Worm gear with feet and output shaft

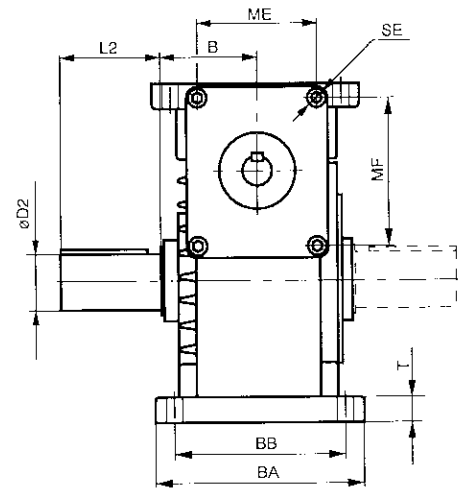
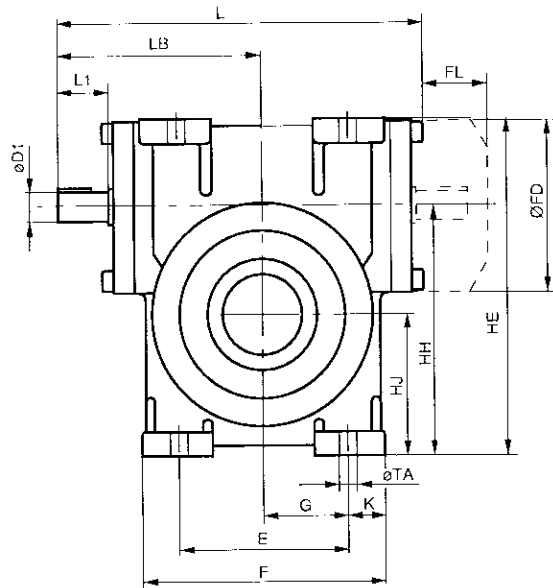

Size	FD	FL
BS 88	140	55
BS 112	140	55

Mounting position OV, OH, OD

Mounting position OV

Size	Ratio	BB	BA	B	E	K	F	G	D2	D1	L2	L1	HH	T	HJ	HE	L	LB	TA	SE	ME	MF	Kgs
BS	<55	140	170	70	140	30	200	70	45	28	82	42	203	20	115	275	300	168	14	M10x18	95	120	40
88	>55	140	170	70	140	30	200	70	45	24	82	42	203	20	115	275	300	168	14	M10x18	95	120	40
BS	<60	175	210	82	175	37.5	250	87.5	55	35	82	58	252	23	140	340	355	202	18	M10x20	95	120	57
112	>60	175	210	82	175	37.5	250	87.5	55	28	82	42	252	23	140	340	339	186	18	M10x20	95	120	57

BS 88-112 Worm gear with hollow shaft

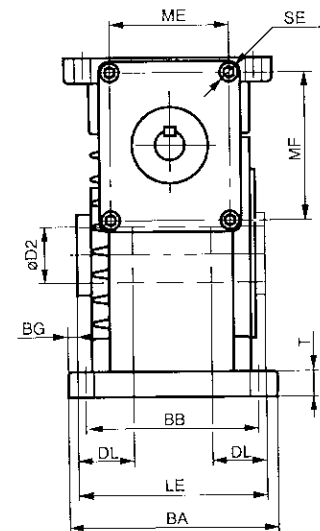
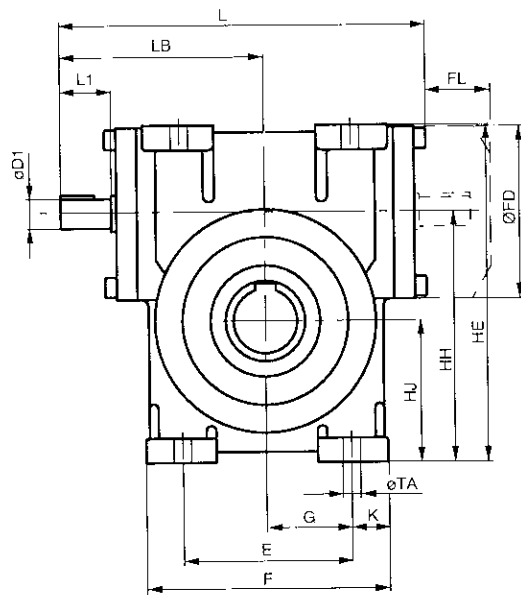

Mounting position O-hollow shaft

Mounting position O-hollow shaft

Size	Ratio	BB	BA	BG	D2	D1	DL	E	F	G	HH	HJ	HE	K	L	LI	LB	LE	T	TA	SE	ME	MF	Kgs
BS	<55	140	170	8	45	28	45	140	200	70	203	115	275	30	300	42	168	154	20	14	M10x18	95	120	39
88	>55	140	170	8	45	24	45	140	200	70	203	115	275	30	300	42	168	154	20	14	M10x18	95	120	39
BS	<60	175	210	18	55	35	50	175	250	87.5	252	140	340	37.5	355	58	202	174	23	18	M10x20	95	120	56
112	>60	175	210	18	55	28	50	175	250	87.5	252	140	340	37.5	339	42	186	174	23	18	M10x20	95	120	56

Shaft tolerance, see page 57

Worm gear BS88-112 with horizontal input shaft and feet

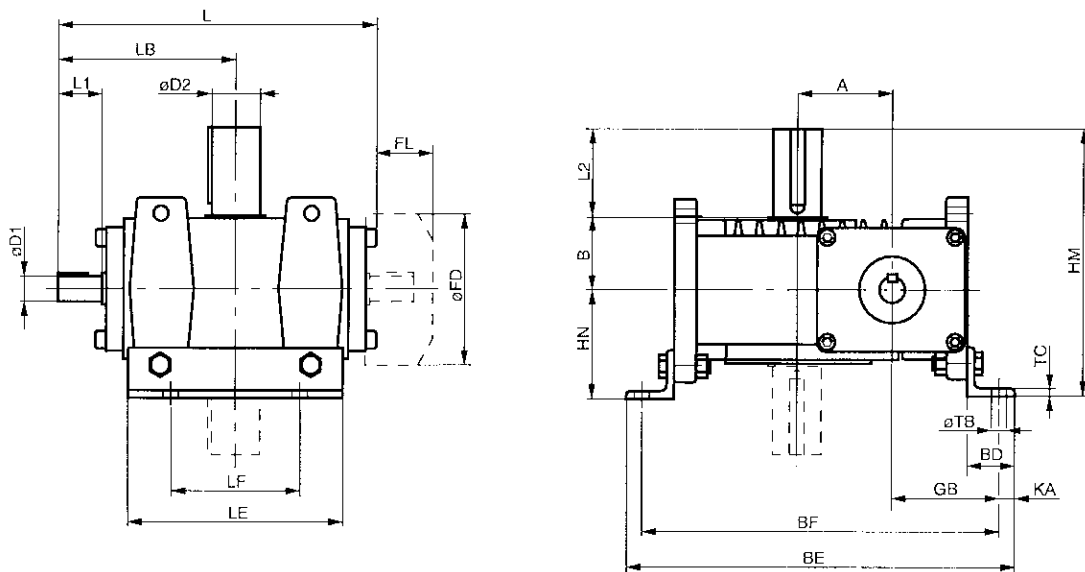

Mounting position HU, HN, HD. Also state position of input shaft A or B. Mounting position HU-A

Size	Ratio	A	B	BD	BF	BE	D1	D2	L2	L1	FD	FL	GB	HM	HN	L	LB	LF	LE	KA	TB	TC	Kgs	Oil (lit)
BS	<55	88	70	45	335	365	28	45	82	42	140	55	102	252	100	300	168	120	200	15	14	7	40	1.5
88	>55	88	70	45	335	365	24	45	82	42	140	55	102	252	100	300	168	120	200	15	14	7	40	1.5
BS	<60	112	82	60	420	460	35	55	82	58	140	55	128	289	125	355	202	135	250	20	18	10	57	1.6
112	>60	112	82	60	420	460	28	55	82	42	140	55	128	289	125	339	186	135	250	20	18	10	57	1.6

BS 88-112 Motorflange

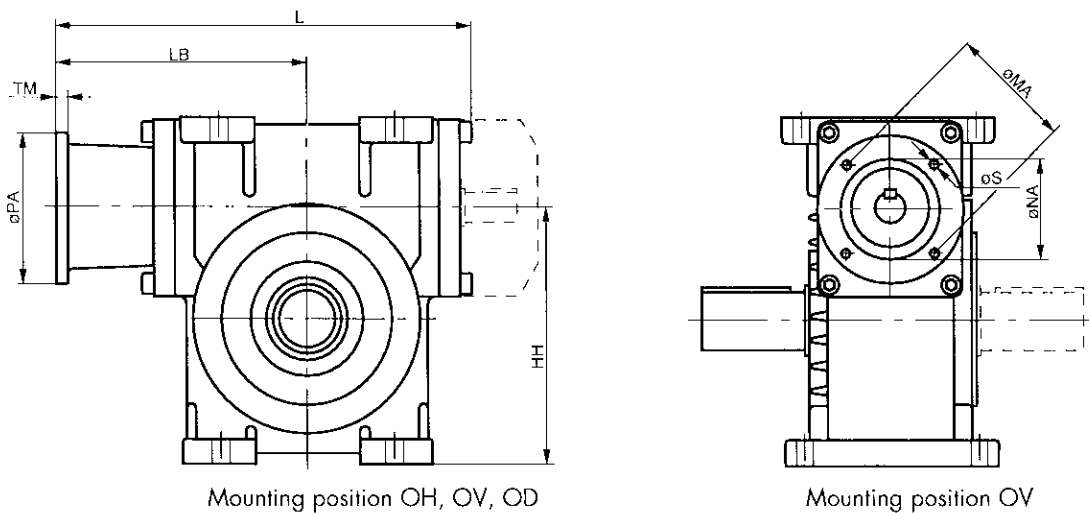

Mounting position OH, OV, OD

Mounting position OV

Size	Motor size	HH	B14 Flange								B5 Flange							
			L	LB	MA	NA	PA	S	TM	L	LB	MA	NA	PA	S	TM	Vikt	
BS	i>55	80	203	345	213	100	80H7	118	7	10	355	223	165	130H7	200	11.5	12	41
	90	203	355	233	115	95H7	140	9	12	355	223	165	130H7	200	11.5	12	41	
	100/112	203	365	233.5	130	110H7	160	9	12	365	233.5	215	180H7	250	14	12	42	
BS	i<55	132	203	398	266	265	230H7	300	14	13	50							
	i>60	90	252	397	244	115	95H7	140	9	12	397	244	165	130H7	200	11.5	12	58
	i>60	100/112	252	408	254.5	130	110H7	160	9	12	408	254.5	215	180H7	250	14	12	59
112	100/112	252	420	267	130	110H7	160	9	12	420	267	215	180H7	250	14	12	61	
	132	252	440	287	265	230H7	300	14	13	67								

Shaft tolerance, see page 57

Execution with output flange and shaft BS40-112

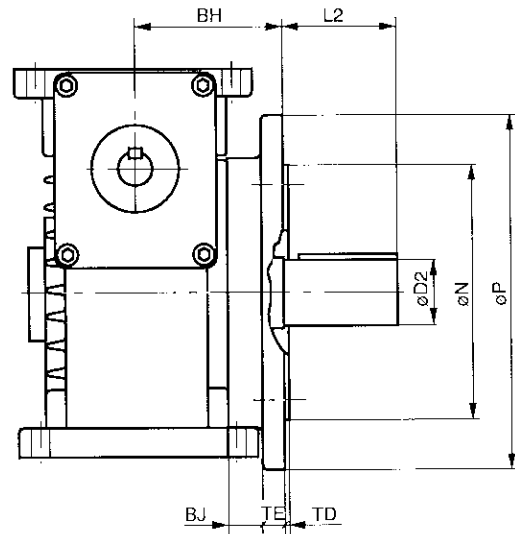
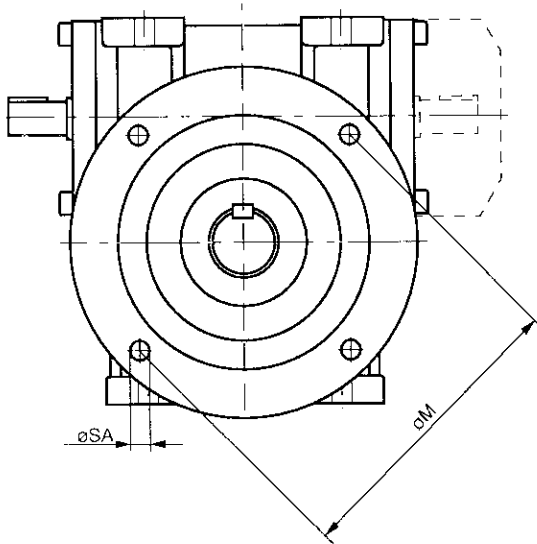
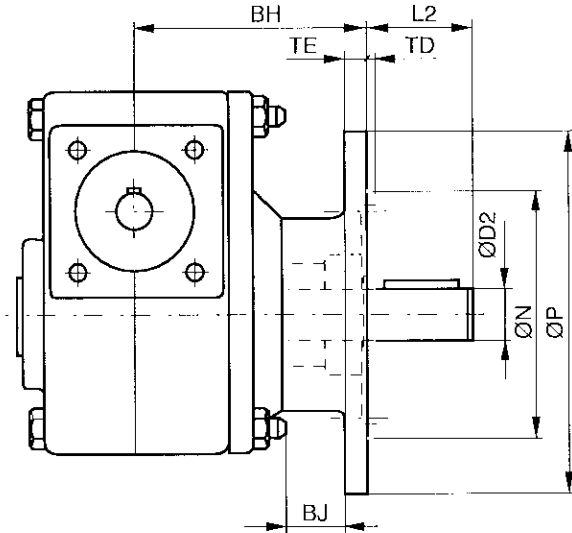
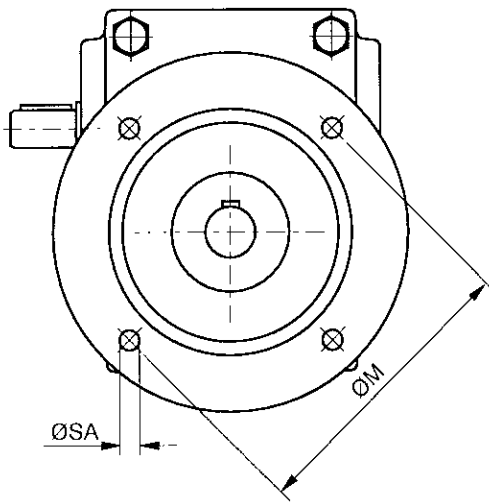

1) Standard execution,
others on request

Size	BH	D2	L2	BJ	M	N	P	SA	TE	TD	Vikt
BS 40	91.5	20	36	28	100	80h7	118	7	10	3	4.1
					115 ¹	95h7 ¹	140 ¹	9			
					130	110h7	160	9			
					165	130h7	200	11			
BS 50	99	25	42	28	100	80h7	118	7	10	3.5	6.6
					115	95h7	140	9			
					130 ¹	110h7 ¹	160 ¹	9			
					165	130h7	200	11			
BS 63	106	30	58	35	130	110h7	160	9	12	3.5	9.3
					165 ¹	130h7 ¹	200 ¹	11			
BS 71	122.4	35	58	32	165	130h7	200	11	12	3.5	13.9
BS 88	105	45	82	24	215	180j6	250	14	15	4	47
BS 112	125	55	82	32	265	230j6	300	14	15	4	69

Shaft tolerance, see page 57

Execution with torque arm

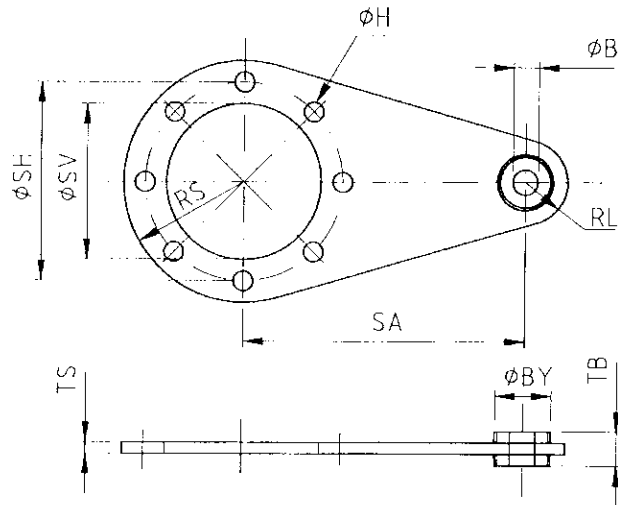

Size	ϕB	ϕBY	ϕH	SA	ϕSH	ϕSV	RL	RS	TS	TB
BS 35	9	20	7 (8x)	100	70	55	15	42.5	4	12

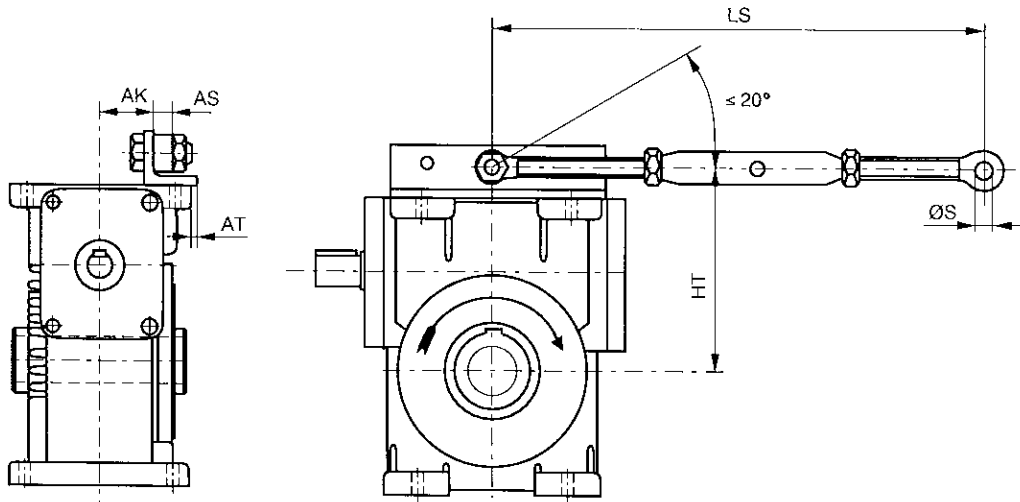
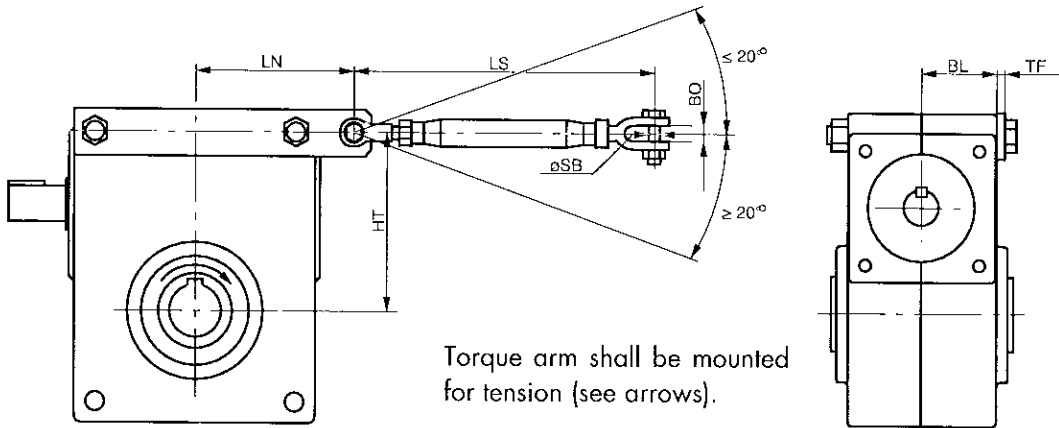

Size	AK	AS	AT	BO	HT	BL	LN	LS min/max	S	SB	TF	Kgs
BS 40	-	-	-	9	76	36.5	70	165/245	-	8	4	4.0
BS 50	-	-	-	9	88	39	85	165/245	-	8	5	5.8
BS 63	-	-	-	11	106	41	103	190/290	-	3/8"	5	7.5
BS 71	-	-	-	11	120	50.7	107.5	190/290	-	3/8"	5	10.7
BS 88	47	18	-	-	190	-	-	460/600	16	-	-	40.0
BS 112	60	18	5	-	240	-	-	480/600	16	-	-	57

Execution with electromagnetic brake

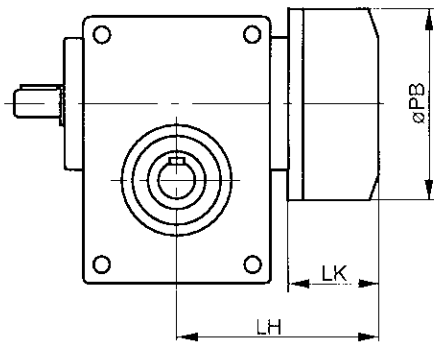

Size	Brake size	Brake torque Nm	øPB	LH	LK	Vikt
BS 40	02	3	85	112	55	4.6
	03	5.7	100	114	60	5.2
	04	12.6	116	120	66	6.3
BS 50	03	6.4	100	131	60	7
	04	14.4	116	137	66	8.1
	05	24	137	146	75	10.4
BS 63	03	6.4	100	142	60	8.7
	04	14.4	116	148	66	9.8
	05	24	137	157	75	12.1
BS 71	04	16	116	159	74	12.3
	05	26	137	159	74	14.3

Shaft bushings

Size	Hollow shaft mm			
	Standard	Bushing		
BS 88	45	40	35	-
BS 112	55	50	45	40

Key and locking screws are supplied with each set of bushes.

Shaft dimensions and tolerances

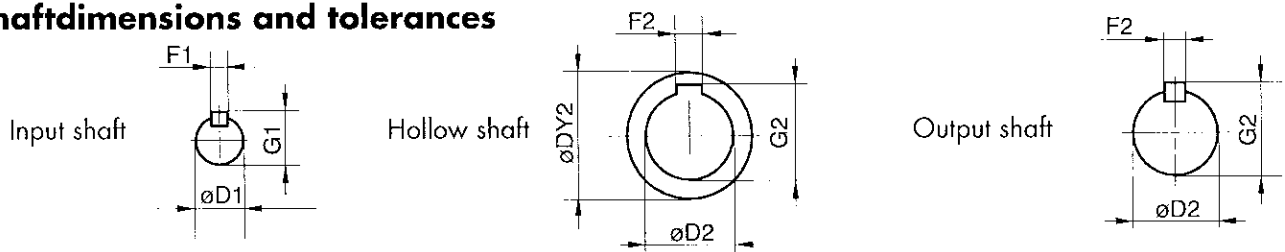

Size	Input shaft			Hollow shaft				Output shaft		
	D1	F1	G1	DY2	D2	F2	G2	D2	F2	G2
BS 35				30d9	20H7	6JS9	22.8	20j6	6h9	22.5
BS 40	14j6	5h9	16	37d9	20H7	6JS9	22.8	20j6	6h9	22.5
BS 50	19j6	6h9	21.5	40d9	25H7	8JS9	28.3	25j6	8h9	28.0
BS 63	19j6	6h9	21.5	45d9	30H7	8JS9	33.3	30j6	8h9	33.0
BS 71	24j6	8h9	27	50d9	35H7	10JS9	38.3	35j6	10h9	38.0
BS 88 i<60	28j6	8h9	31	65d9	45H7	14D10	48.8	45k6	14h9	48.5
BS 88 i>60	24j6	8h9	27							
BS 112 i<60	35j6	10h9	38	80d9	55H7	16D10	59.3	55k6	16h9	59.0
BS 112 i>60	28j6	8h9	31							

Keyway acc. to SMS 2305

Maximum input speed n_1

	Size							
	35	40	50	63	71	88	112i<60:1	112i>60:1
n_1 , max rpm	4500	6000	5500	5000	4500	4000	3000	3500

Worm Gear with environmental classification

With BS (size 40-71) classified acc to environmental class we are able to recommend the gears for installation in ambient conditions where normally

only materials in stainless steel are accepted. The gears are classified acc to environmental class M2-M3, Swedish standard stBK-N4.

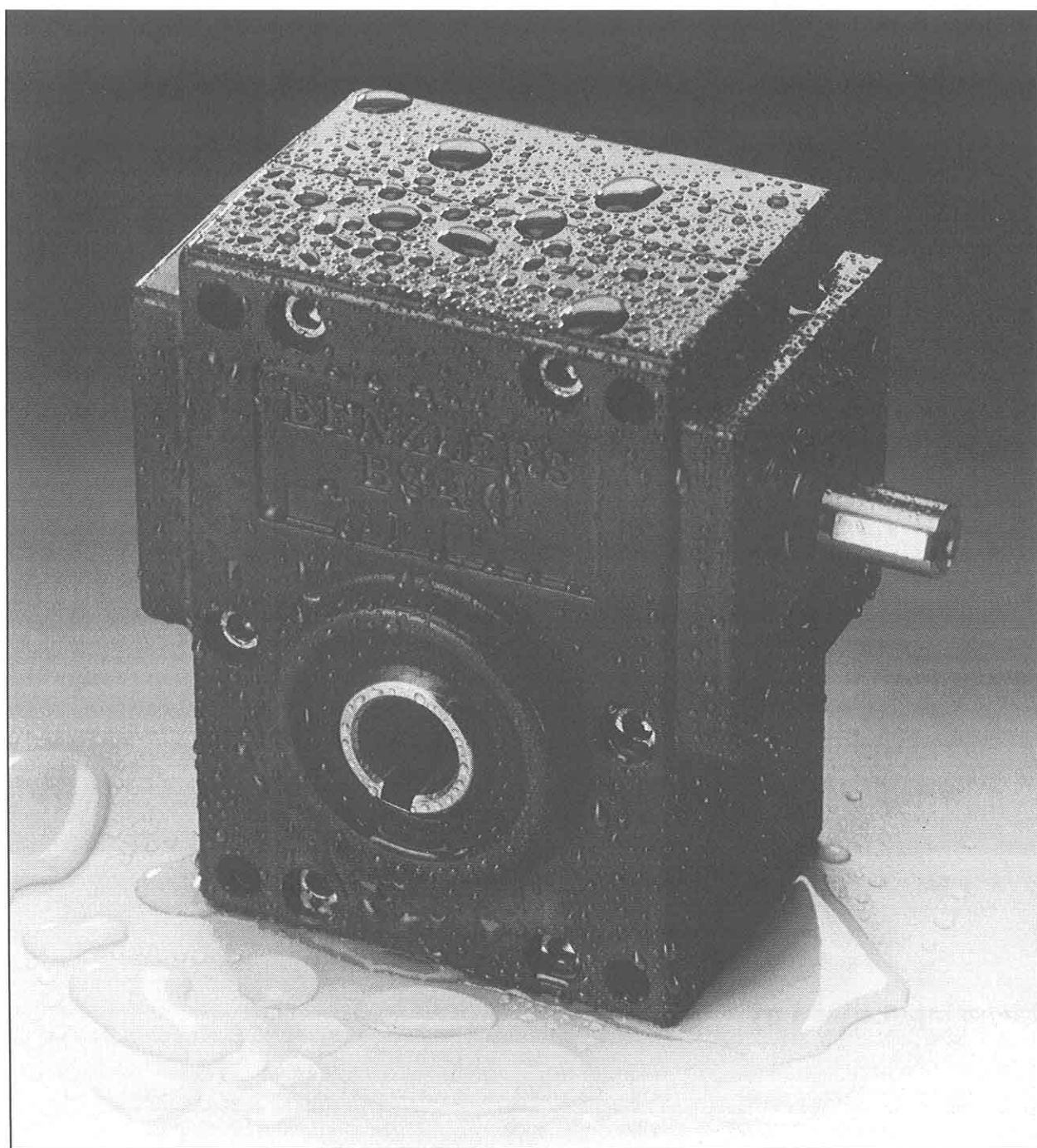

Advantages:

- No corrosion
- Low weight (aluminium)
- High rating
- IEC-standard
- High surface finish
- Modern design
- No maintenance
- Easy handling
- Large number of motor alternatives

Product specification

- coated gear case, flanges and feet
- stainless steel bolts in gear housing
- stainless steel hollow shaft (SS 2346 alt. 2382)
- stainless steel output shaft
- surface for seal ring protected by stainless steel sleeve (SS 2333)
- Seal rings of viton
- ratings acc to catalogue

- high resistance against corrosion
- very hard and resistant against wear
- low tendency to be sticky
- hygienic

Application examples

- food industry
- paper and cellulose industry
- pharmaceutical industry
- chemical industry
- defence industry
- marine and mobile installations
- all outdoor installations

Type of coating

The coating is a recently developed surface coating method for aluminium.

The coating means that the material surface is, by a chemical process, converted into an aluminium oxide, which gives a very hard, ceramic, surface finish.

The oxide layer is then impregnated and coated with plastic. With heat treatment a very strong and resistant connection between oxide and plastic is created.

Unique coating qualities:

Gear		BS 40	BS 50	BS 63	BS 71
Catalogue rating, Nm	max	78	120	197	315
	min	31	62	92	143
Output speed, rpm	max	429	358	369	381
	min	9	9	7	7
Max static load, Nm		93	150	250	400
Radial force on output shaft, N		2000	2700	4000	5000
Thrust load on output shaft, N		2000	2500	3500	4500

Applications

Worm gear with shrink fit

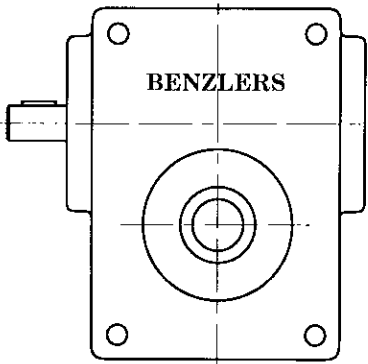

Size	Shrink disc	A	B	øC	øD	Nm
BS 40	HSD 30-22	119	46	60	20	155
BS 50	HSD 36-22	128	49	72	25	350
BS 63	HSD 44-22	133	50.5	80	30	440
BS 71	HSD 44-22	154	61	80	35	770

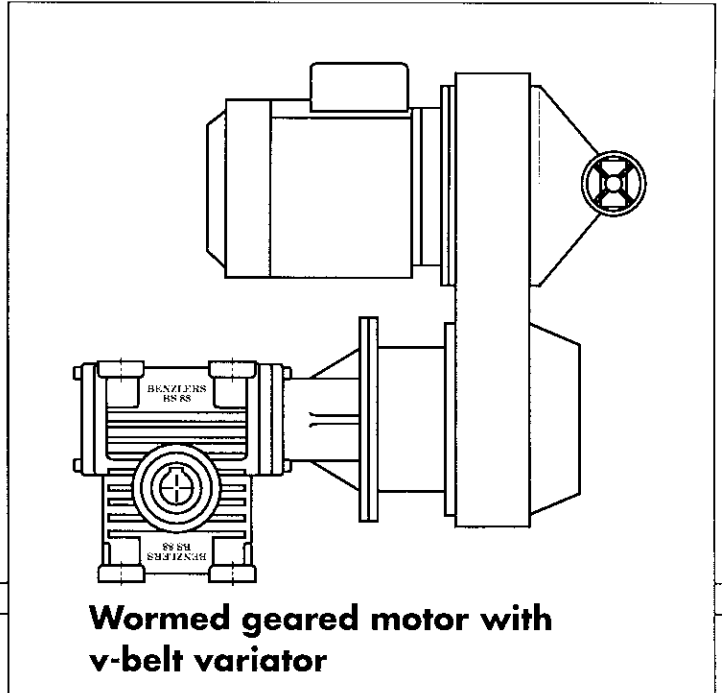
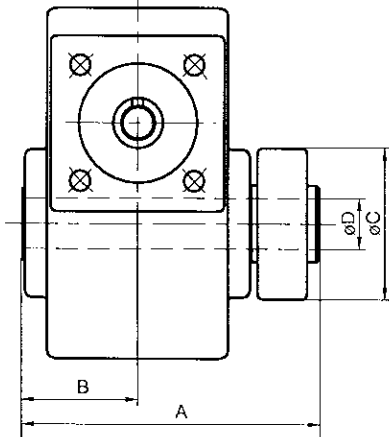

Wormed geared motor with v-belt variator

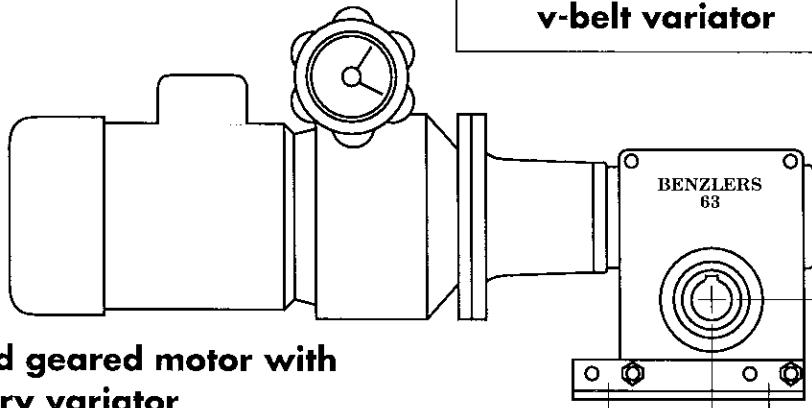

Wormed geared motor with planetary variator

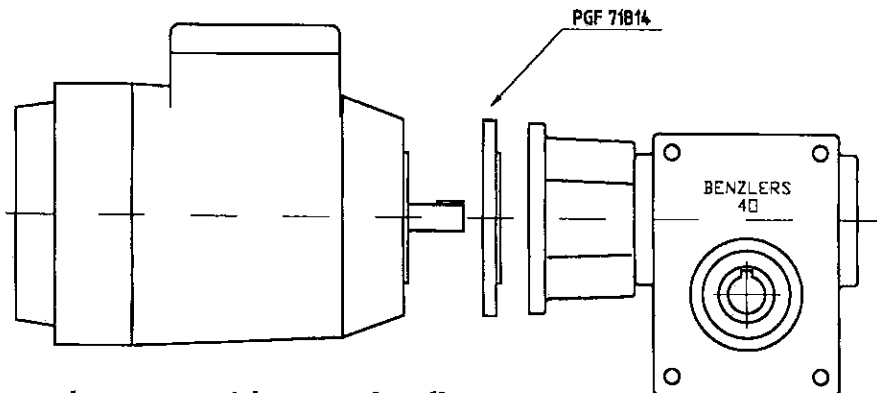

Wormed geared motor with encoder flange (PGF)

Benzlers "electronic" catalogue

We at Benzlers has as one of our goals to continuously help our customers to increase their profitability and efficiency. As a step on this road we have made programs for CAD and PC with drawings and calculation programs for our whole range of gears, which will simplify your selection of gears.

This electronic catalogue will help you with;

Selection of gear and geared motor.

Documentation of selection and related power demands etc.

Detail drawing and Layout drawing.

With these programs you will win considerable amount of time in the design stadium and will gain higher development speed in your own business. Except gaining time the selection will secure that the optimal gear combination is selected in each and every case. Thereby the risk for expensive breakdown will decrease to a minimum and also unnecessary high cost if too big gears are selected .



Mounting

General

1. The gear should be placed on a flat and solid foundation.
2. Sprocket, pulley or coupling on shaft can not be mounted with force. This will damage the gear.
3. To avoid increasing load on shafts and bearings, the gear and the driven machine should be carefully aligned, even if an elastic coupling is used.
4. If sprockets are used on the output shaft the preferable direction of pull should be such that the gear housing will be pressed towards the foundation.
5. When situated outdoors or working under adverse conditions as heat, dust or damp, the gear must be provided with sufficient protection, but the cooling air circulation must not be unduly restricted.

Hollow shaft gears

1. The gear is normally mounted on a shaft with tolerance js6. The hollow shaft have tolerance H7. Grease the shaft with Molykote BR2 or equivalent before the gear is mounted. The gear shall not be mounted with force. The gear shall be locked against axial movement. Set screws in hollow shaft can be used for BS88 and 112.

Lubrication

Before delivery BS40-112 are filled with synthetic oil - Mobil SHC 634 and BS35 with synthetic grease - Mobil SHC 007. This type of lubrication is extra suitable for worm gears.

At normal condition the oil/grease never needs to be changed.
Ambient temperature -30°C - +30°C.

Maintenance

1. Benzler worm gears are lubricated for life with synthetic oil/grease and are therefore maintenance free.
2. Check that there are no leakage.
3. The worm gears shall under no circumstances be entirely filled with oil or grease.

Running in

1. The gear should be run under low load conditions during the first 10-30 hours. Then the load should gradually be increased to full load.
2. The length of the running-in period depends on the size of the gear and the actual working conditions.
3. When increasing the load the temperature of the gear can exceed the ambient temperature by 60-70° C. Oil- and gear temperatures of 95-100° C are harmless and have no influence on the function of the gear. When the temperature exceeds 100° C special sealrings must be used.
4. Gears which are not used for a long period should be run for short periods, approximately every third month.

Questionnaire

To specify a drive precisely, certain data are essential. The most important questions are listed in the table below. If you do not have the required data available in this form, we advise you to use a technical handbook or other suitable documentation. Should you have any question, please do not hesitate to contact us, Benzlers specialists will be pleased to assist you.

Load designation

Output power (kW): P_e	at n_{max}	at n_{min}	Motor			
			Enclosure IP			
Output speed (RPM):	n_{emax}	n_{emin}	Operating voltage	motor (V)	brake (V)	frequency (Hz)
Output torque (Nm): T_e	at n_{max}	at n_{min}	Brake torque (Nm)			
Overhung load (N): F_{r2e}	at output shaft	at input shaft	Ambient factors			
			Ambient temperature (°C)			
Axial thrust load (N): F_{a2e}	at output shaft	at input shaft	Load cycle / Duty cycle	S /	% ED	
(away + / towards -)			Starting frequency (1/h)			
Moment of inertia (kgm ²):	at output shaft	at input shaft				
Unit type and mounting position (see page 11)						

Additional information:

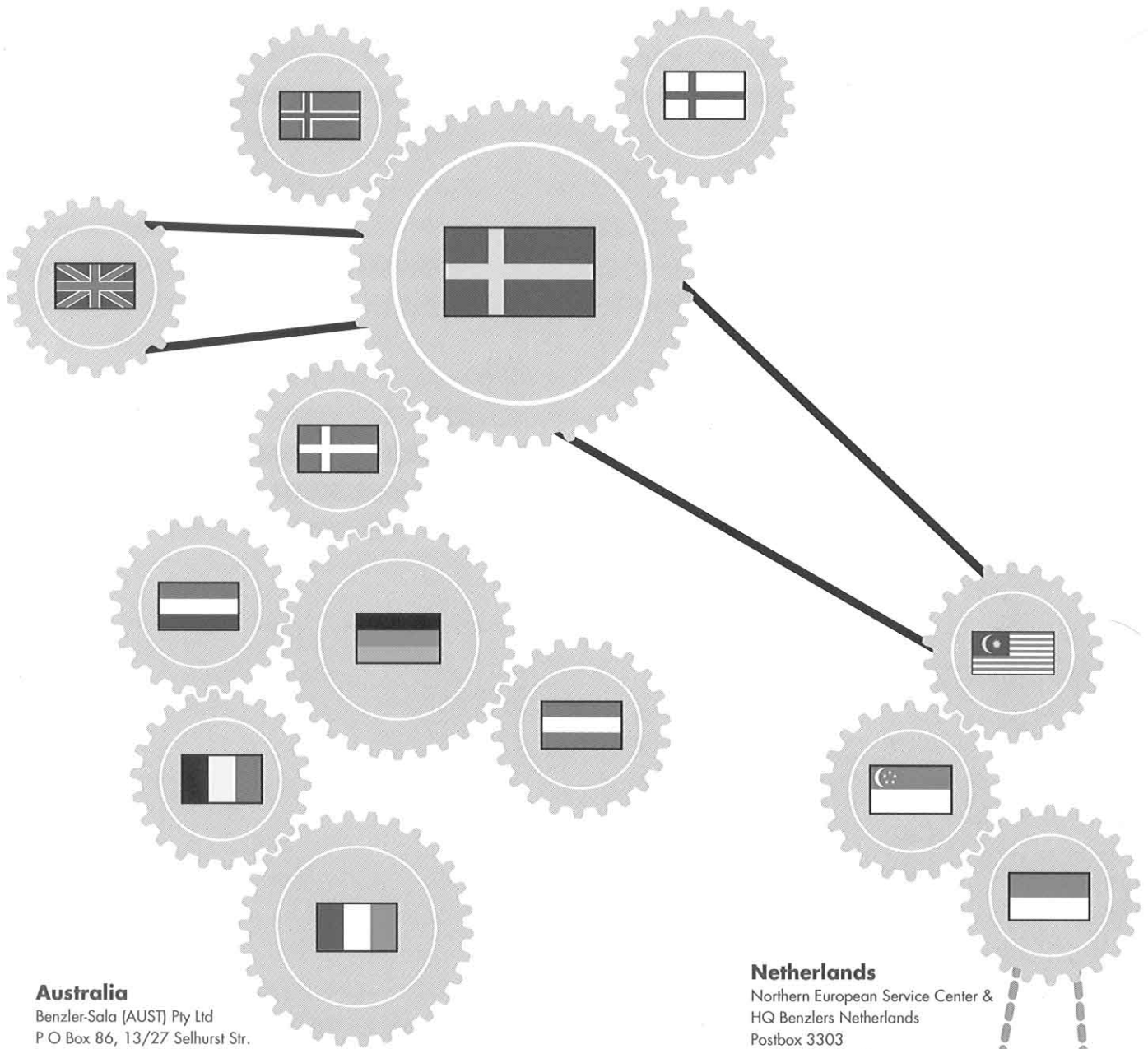

Australia

Benzler-Sala (AUST) Pty Ltd
 P O Box 86, 13/27 Selhurst Str.
 Coopers Plains QLD 4108
 Phone +61 - 7 3345 2444
 Telefax +61 - 7 3345 7222

Austria

Benzler Ant. technik Ges MBH
 Urnenhainweg 7
 AT-4050 Traun
 Phone +43 - 7229 618 91
 Telefax +43 - 7229 618 84

Belgium

Benzler Belgium BVBA
 Contact the Northern European
 Service Center (Netherlands)
 Phone +32 - 2 583 15 18
 Telefax +32 - 2 582 68 47

Denmark

Benzler Transmission A/S
 Hammerholmen 39
 DK-2650 Hvidovre
 Phone +45 - 36 34 03 00
 Telefax +45 - 36 77 02 42

Finland

OY Benzler AB
 PB 3
 FI-02211 Espoo
 Phone +358 - 9 8870 630
 Telefax +358 - 9 8870 631

France

Benzler Transmissions France
 Contact the Northern European
 Service Center (Netherlands)
 Phone +33 130 32 79 00
 Telefax +33 130 32 80 40

Germany

Benzler Antriebstechnik GmbH
 Contact the Northern European
 Service Center (Netherlands)
 Phone 0800 350 40 00
 Telefax 0800 350 40 01

Great Britain

Benzler (UK) Limited
 Salt House Road
 Brackmills Ind Estate
 GB-Northampton NN4 7EX
 Phone +44 - 1604 765 281
 Telefax +44 - 1604 765 243

Italy

Benzler Ferri S.p.A.
 Via F.lli Rosselli 16
 IT-420 19 Scandiano (RE)
 Phone: +39 05 22 763 314
 Telefax: +39 05 22 981 758

Malaysia

Benzler (M) Sdn Bhd
 No. 24 Jalan TP J3
 Taman Perindustrian Jaya
 MY-47200 Subang, Selangor
 Phone +60 - 3 745 0668
 Telefax +60 - 3 746 1436

Netherlands

Northern European Service Center &
 HQ Benzlers Netherlands
 Postbox 3303
 NL-5902 RH Venlo
 Phone +31 - 773 245 900
 Telefax +31 - 773 245 901

Norway

Benzler A/S
 PO Box 73 Leirdal
 Stromsveien 372
 NO-1008 Oslo
 Phone +47 - 22 90 94 30
 Telefax +47 - 22 90 94 11

Singapore

Benzler (FE) Pte Ltd
 1 Clementi Loop #03-08
 Singapore 129808
 Phone +65 - 469 0777
 Telefax +65 - 469 2083

BENZLERS

AB Benzlers Box 922, SE-251 09 Helsingborg, SWEDEN

Phone +46 42 18 68 00 Telefax +46 42 21 88 03 <http://www.benzlers.se>