

Series K

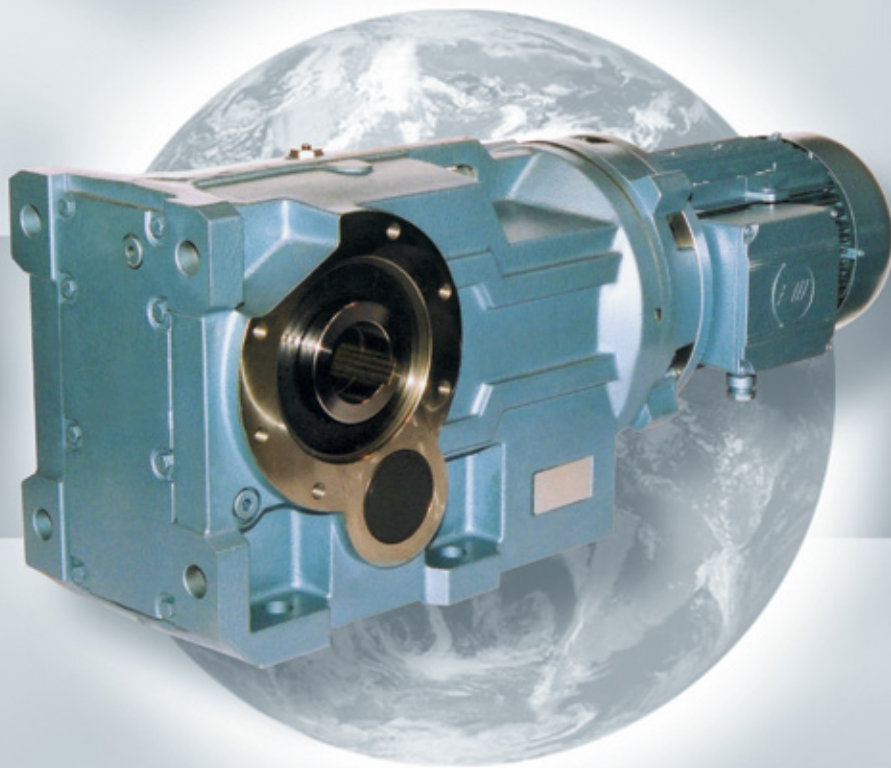

TEXTRON POWER TRANSMISSION

PRODUCTS IN THE RANGE

0105

Serving an entire spectrum of mechanical drive applications from food, energy, mining and metal; to automotive, aerospace and marine propulsion, Textron Power Transmission is here to make a positive difference to the supply of drive solutions.

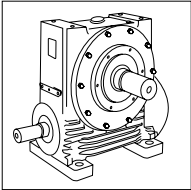

Series A
Worm gear units and geared motors in single & double reduction types

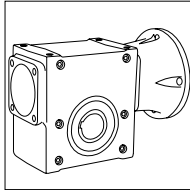

Series B
Conax helicoidal gear geometry right angle gearmotors and reducers

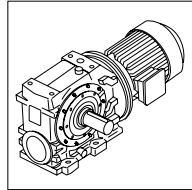

Series C
Right angle drive helical worm geared motors & reducers

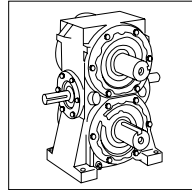

Series D
Dual gears on parallel output shafts

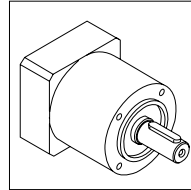

Series E
Economical planetary servo gearboxes

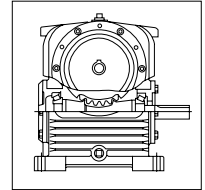

Extruder Drive
Rugged duty reducer takes high screw pressure

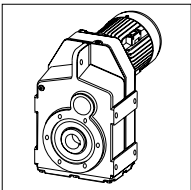

Series F
Parallel helical shaft mounted geared motors & reducers

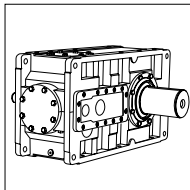

Series G
Helical parallel shaft & bevel helical right angle drive gear units

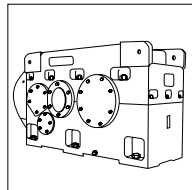

Series H
Large helical parallel shaft & bevel helical right angle drive units

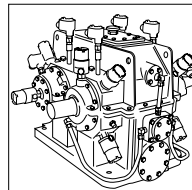

Highspeed
Helical parallel shaft high speed units

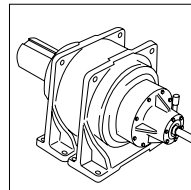

HTP
High torque planetary gear units

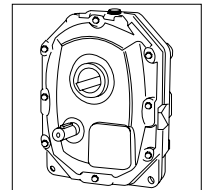

Series J
Shaft mounted helical speed reducers

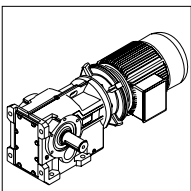

Series K
Right angle helical bevel helical geared motors & reducers

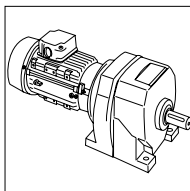

Series M
In-line helical geared motors & reducers

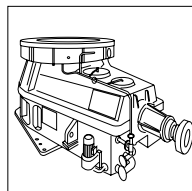

Mill Drives
Bevel planetary vertical mill drives

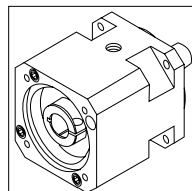

Series P
Precision planetary servo gearboxes

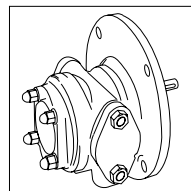

Pumps
Double helical gear pumps

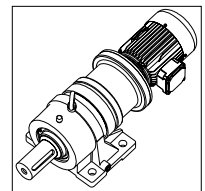

Series Q
In-line planetary geared motors & reducers

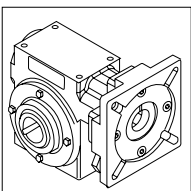

Model RG
Right angle gearhead in two precision levels

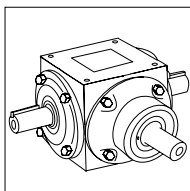

Series R
Right angle spiral bevel gear unit

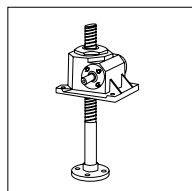

Series S
Screwjack worm gear units

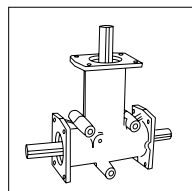

Series T
Right angle straight bevel gear unit

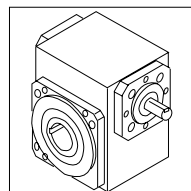

Series W
Precision right angle servo gearboxes

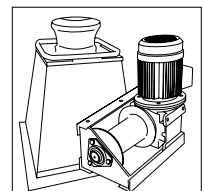

Winches & Capstans
Custom engineered solutions

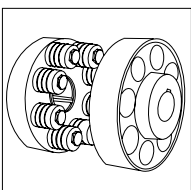

Series X Cone Ring
Pin and bush elastomer coupling

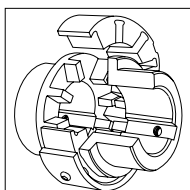

Series X Flexiwrap
Double flexing elastomer coupling

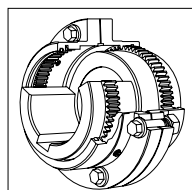

Series X Gear
Torsionally rigid, high torque coupling

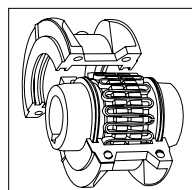

Series X Grid
Double flexing steel grid coupling

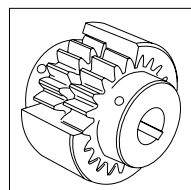

Series X Nylicon
Gear coupling with nylon sleeve

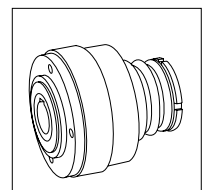

Series X Torque Limiter
Overload protection device

Textron Power Transmission can create custom engineered transmission solutions of any size and configuration.

0203

General Description _____	1
Unit Designations _____	2
Explanation and use of Ratings and Service Factors _____	3
Load Classification by Applications _____	4
Selection Procedure _____	5 - 6
Output Options _____	7 - 8
Motor Adaptors _____	9 - 10
Lubrication _____	11
Mounting Positions _____	12
Unit Handings _____	13
MOTORISED	
Motor Performance Data and Standard Motor Variants Available _____	15 - 16
Brake Motors _____	17
Motor Details _____	18
Additional Motor Features _____	19
Additional Gearbox Features _____	20
Selection Tables - Geared Motors _____	21 - 59
Dimension Sheets - Geared Motors _____	60 - 62
Motorised Backstop Module _____	63
REDUCER	
Overhung & Axial Loads on Shafts _____	65 - 66
Ratings - Input Power / Output Torque _____	67 - 76
Dimension Sheets - Speed Reducers _____	77 - 78
Thermal Power Ratings / Dimensions of Unit with Fan _____	79 - 80
Reducer Backstop Module _____	81
OUTPUT OPTIONS	
Dimensions of Outputshaft Options _____	82
Kibo Bushes _____	83 - 84
Shrink Disc _____	85
Taper Release Bushing _____	86 - 87
Dimension Sheet - Torque Bracket _____	88
Dimensions of B5 (D) Flange units _____	89
Dimensions of B14 (C) Flange units _____	90
Dimension Sheet - Assembly / Disassembly _____	91 - 92
Shipping Specification _____	93 - 94

0106

Series K right angle drive helical bevel helical geared motors offer ratios from 8 : 1 to 160 : 1 in three stages or up to 10,000 : 1 in five stages and 36,000 : 1 in 6 stages. Motors are available up to 90kW and output torque capacity up to 12,300Nm. The Series K geared motor is designed with integral cast feet for base or end mounting and can be offered with single or double extended output shafts. Units are also available shaft mounted or with output flanges and are available for mounting horizontally or vertically. The units can also be offered with a bolt on torque reaction bracket and all variants are available either motorised or with an input shaft assembly.

Adding to the new range of Textron Power Transmission geared motors this product takes advantage of our many years of accumulated design expertise together with the use of high quality materials and components. The end result is a series of speed reducing geared motors offering high load carrying capacities, increased efficiency, quiet running and reliability.

The range includes:

9 sizes of unit K03, K04, K05, K06, K07, K08, K09, K10 and K12

- Version B - standard unit with feet
- Version F or H - standard unit with output flange
- Version T or Q - standard unit with torque bracket

Unit Types:

- Unit type M - Motorised with IEC standard motor
- Unit type N - Motorised with NEMA standard motor
- Unit type H - Motorised with high efficiency motor (EFF1 or EPACT)
- Unit type E - Motorised with NEMA high efficiency motor (EPACT)
- Unit type G - Unit to allow fitting of IEC motor (non Textron PT motor)
- Unit type A - Unit to allow fitting of NEMA motor (non Textron PT motor)
- Unit type R - Reducer unit
- Unit type S - Reducer unit with fan kit
- Unit type W - Reducer unit with backstop CCW rotation
- Unit type X - Reducer unit with backstop CW rotation
- Unit type Y - Reducer unit with fan and backstop CW rotation
- Unit type Z - Reducer unit with fan and backstop CCW rotation

Design Features Include:

- Patented standard motor connection (IEC or NEMA)
- Ability to fit double oil seals, on input or output shaft as required
- All units are dimensionally interchangeable with other major European manufacturers
- Braked geared motors are available as standard
- Units are manufactured and assembled from a family of modular kits for distributor friendliness minimising inventory and maximising availability
- Motorised units can be fitted with a backstop module and reducer units can be fitted with a backstop and fan.

As improvements in design are being made continually this specification is not to be regarded as binding in detail and drawings and capacities are subject to alteration without notice. Certified drawings will be sent on request.

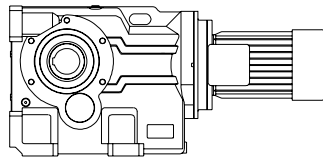

Motorised
Triple reduction
Standard unit with feet

*

K	0	8	3	2	5	0	.	B	M	C	-	1	B	7	.	5	A	-	-
---	---	---	---	---	---	---	---	---	---	---	---	---	---	---	---	---	---	---	---

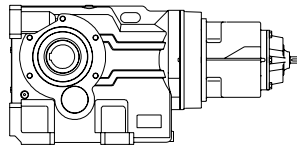

Reducer
Quintuple reduction
Standard unit with feet

*

K	0	8	5	2	1	2	C	B	R	C	-	1	-	-	-	-	-	-	-
---	---	---	---	---	---	---	---	---	---	---	---	---	---	---	---	---	---	---	---

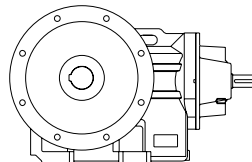

Reducer
Triple reduction
Standard unit with output flange on left

*

K	0	9	3	1	5	0	.	F	R	H	-	1	-	-	-	-	-	-	-
---	---	---	---	---	---	---	---	---	---	---	---	---	---	---	---	---	---	---	---

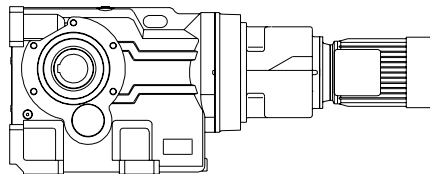

Motorised
Quintuple reduction
Standard unit with feet

*

K	0	8	5	2	1	2	C	B	M	C	-	1	B	.	2	5	A	-	-
---	---	---	---	---	---	---	---	---	---	---	---	---	---	---	---	---	---	---	---

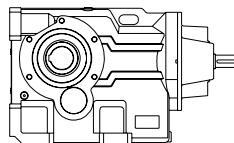

Reducer
Triple reduction
Standard unit with feet

*

K	0	8	3	2	5	0	.	B	R	C	-	1	-	-	-	-	-	-	-
---	---	---	---	---	---	---	---	---	---	---	---	---	---	---	---	---	---	---	---

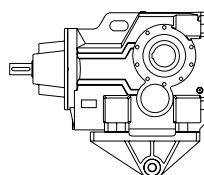

Reducer
Triple reduction
Standard unit with torque bracket

*

K	0	8	3	2	5	0	.	T	R	H	-	1	-	-	-	-	-	-	-
---	---	---	---	---	---	---	---	---	---	---	---	---	---	---	---	---	---	---	---

* Typical unit designations

0203

Gearbox Codes														Motor Codes					
Series	Size of Unit			No of Reductions	Revision Version	Nominal Overall Ratio			Unit Version	Type of Unit	Output Shaft	Motor Adaptor	Mounting Position	Geared Motor Power	No of Motor Poles	Additional Motor Features	Additional Gearbox Features		
1	2	3	4	5	6	7	8	9	10	11	12	13	14	15	16	17	18	19	20
K																			
K	0	8	3	2	5	0	.	B	M	C	-	1	D	.	1	8	A	-	-

*
Example

20 - Additional Gearbox Features
Double Oil Seal, Motorised Backstop Etc
eg See Page 20

1 - Series K
Range

2, 3 - Size of Unit
 Through

4 - No of Reductions
 Through

5 - Revision Version
 For Sizes 03 to 08
 For Sizes 09 to 12

6, 7, 8 - Nominal Overall Ratio
eg See Pages 67 - 76

9 - Unit Version
Standard Unit with Feet
STD Unit with Output Flange on Left ** on Right **
STD Unit with Torque Bracket on Left ** on Right **

10 - Type of Unit
 - Motorised with IEC standard motor
 - Motorised with NEMA standard motor
 - Motorised with IEC high efficiency motor (EFF1 or EPACT)
 - Motorised with NEMA high efficiency motor (EPACT)
 - Unit to allow fitting of IEC motor (non Textron PT motor)
 - Unit to allow fitting of NEMA motor (non Textron PT motor)
 - Reducer unit
 - Reducer unit with fan kit
 - Reducer unit with backstop CCW rotation
 - Reducer unit with backstop CW rotation
 - Reducer unit with fan and backstop CW rotation
 - Reducer unit with fan and backstop CCW rotation

19 - Additional Motor Features
eg See Page 19
For Types Without Motor Enter

18 - No of Motor Poles
 No motor
50 Hz 60 Hz
4 Pole (Std) 1500 rpm 1800 rpm
4 Pole (High) 1500 rpm 1800 rpm
6 Pole (Std) 1000 rpm 1200 rpm
6 Pole (High) 1000 rpm 1200 rpm
2 Pole 3000 rpm 3600 rpm
8 Pole 750 rpm 900 rpm
 Dual speed or special motor

15, 16, 17 - Geared Motor Powers
Motor Power Required
eg See Page 21 - 59
For reducer and non standard motor types enter

13, 14 - Mounting Position
eg See Page 12

12 - Motor Adaptor For Unit Types Column 10 Entries M, N, H, E, G or A
See Pages 9 and 10
For All Other Types Enter

11 - OUTPUT SHAFT
Standard Single Extension on Left ** on Right **
Standard Double Extension
Extended Shaft for Flange Mounted Units
Standard Hollow Shaft
Standard Kibo Shaft - entry depends on shaft diameter see page 84
Standard Taper Release on Left ** on Right **
Standard Shrink Disc on Left ** on Right **
See pages 7 & 8 for inch options

* This Page May Be Photocopied Allowing The Customer To Enter Their Order
** Looking on Inputshaft Mounting Position 1 (See page 13 for unit handings)

EXPLANATION & USE OF RATINGS & SERVICE FACTORS

0108

Gear unit selection is made by comparing actual loads with catalogue ratings. Catalogue ratings are based on a standard set of loading conditions, whereas actual load conditions vary according to type of application. Service Factors are therefore used to calculate an equivalent load to compare with catalogue ratings.
 i.e. Equivalent Load = Actual Load x Service Factor

Mechanical ratings and service factors Fm and Fs

Mechanical ratings measure capacity in terms of life and/or strength, assuming 10 hr/day continuous running under uniform load conditions.

Catalogue ratings allow 100% overload at starting, braking or momentarily during operation up to 10 hours per day.

The unit selected must therefore have a catalogue rating at least equal to half maximum overload.

Mechanical Service Factor Fm (Table 1) is used to modify the actual load according to daily operating time, and type of loading.

Load characteristics for a wide range of applications are detailed in Table 3 opposite, which are used in deciding the appropriate Service Factor Fm from Table 1.

If overloads can be calculated, or accurately assessed, actual loads should be used instead of Fm.

For units subjected to frequent stop/starts overloads in excess of 10 times/day multiply factor Fm x Factor Fs (table 2).

For applications where units are to operate in extremely dusty or moist/humid atmospheres unit selection should be referred to Textron Power Transmission application engineers.

Table 1. Mechanical Service Factor (Fm)

Prime mover	Duration of service-hrs per day	Load classification-driven machine		
		Uniform mass acceleration factor ≤ 0.2	Moderate mass acceleration factor ≤ 3	Heavy mass acceleration factor ≤ 10
Electric motor, steam turbine or hydraulic motor	Under 3	0.80	1.00	1.50
	3 to 10	1.00	1.25	1.75
	Over 10	1.25	1.50	2.00
Multi-cylinder internal combustion engine	Under 3	1.00	1.25	1.75
	3 to 10	1.25	1.50	2.00
	Over 10	1.50	1.75	2.25
Single cylinder internal combustion engine	Under 3	1.25	1.50	2.00
	3 to 10	1.50	1.75	2.25
	Over 10	1.75	2.00	2.50

Mass acceleration factor = $\frac{\text{all external moments of inertia}^*}{\text{moment of inertia of driving motor}}$ * calculated with reference to the motor speed

Table 2. Number of Starts Factor (Fs)

Start / Stops per hour (1)	Up to 1	5	10	40	60	≥ 200
Factor Fs	1.00	1.03	1.06	1.10	1.15	1.20

Note: (1) Intermediate values are obtained by linear interpolation

0106

EXAMPLE APPLICATION DETAILS

Absorbed power of driven machine = 13kW
 Output speed of gearbox or Input speed of machine = 44rev/min
 Application = Uniformly loaded belt conveyor
 Duration of service (hours per day) = 24hrs
 Mounting position = 1
 Ambient temperature = 20°C
 Running time (%) = 100%

1 DETERMINE MECHANICAL SERVICE FACTOR (Fm)

Refer to Load Classification by Application, table 3, page 4

Application = Uniformly loaded belt conveyor

Conveyors-uniformly loaded or fed		U = Uniform load
apron assembly	U	
belt	U	
bucket chain	U	

Refer to mechanical service factor (Fm), table 1, page 3

Duration of service (hours per day) = 24hrs

Prime mover	Duration of service-hrs per day	Load classification-drive	
		Uniform	Moderate Shock
Electric motor, steam turbine or hydraulic motor	Under 3	0.80	1.00
	3 to 10	1.00	1.25
	Over 10	1.25	1.50

Therefore mechanical service factor (Fm) = 1.25

2 DETERMINE REQUIRED OUTPUT TORQUE AT GEARBOX OUTPUTSHAFT

$$\text{Absorbed output torque} = \frac{\text{Absorbed power} \times 9550}{\text{Gearbox output speed}}$$

$$\frac{13 \times 9550}{43} = 2887 \text{ Nm}$$

3 SELECT GEARED MOTOR

Refer to selection table one motor size larger than absorbed power.

Absorbed power = 13kW, therefore refer to 15kW selection table, page 51

Always select from 4 POLE selection table in the first instance as this offers a more economical solution.

Required output speed of gearbox = 43 rev/min

15 kW	N2 R/MIN	i	M2 Nm	Fm	N	UNIT DESIGNATION	Kg	Motor Frame Size
	Output Speed	Ratio	Output Torque	Service Factor	Overhung Load			
4 POLE	181	8.03	757	3.39	34000	K 0 9 3 1 8 . 0 _ M _ _ _ 1 5 . A - - Column Entry 1 Through 20 Spaces to be filled when entering order	272	160L
	97	14.94	1408	2.68	34000			
	81	17.93	1700	2.05	34000			
	73	20.03	1893	1.88	34000			
	67	21.61	2040	2.03	34000			
	60	24.14	2280	1.85	34000			
	52	27.78	2621	1.44	34000			
	46	31.67	3005	1.26	34000			
	43	33.47	3162	1.33	34000			
	38	38.16	3596	1.17	34000			

Go to point 4

0207

4 CHECK OUTPUT TORQUE

Output torque (M2) of selected unit must be equal or more than required output torque at gearbox outputshaft.

Required output torque at gearbox outputshaft = 2887 Nm

15 kW	N2 R/MIN	i	M2 Nm	Fm	N	UNIT DESIGNATION	Kg	Motor Frame Size
	Output Speed	Ratio	Output Torque	Service Factor	Overhung Load			
4 POLE	181	8.03	757	3.39	34000	K 0 9 3 1 8 . 0 _ M _ - _ - 1 5 . A - -	272	160L
	97	14.94	1408	2.68	34000	1 6 .		
	81	17.93	1700	2.05	34000	1 8 .		
	73	20.03	1893	1.88	34000	2 0 .		
	67	21.61	2040	2.03	34000	2 2 .		
	60	24.14	2280	1.85	34000	2 5 .		
	52	27.78	2621	1.44	34000	2 8 .		
	46	31.67	3005	1.26	34000	3 2 .		
	43	33.47	3162	1.33	34000	3 6 .		
	38	38.16	3596	1.17	34000	4 0 .		

Selected unit's output torque (M2) = 3162 Nm, therefore unit is acceptable

5 CHECK SERVICE FACTOR

Service factor (Fm) of selected unit must be equal or more than required service factor.

Required service factor of gearbox = 1.25

15 kW	N2 R/MIN	i	M2 Nm	Fm	N	UNIT DESIGNATION	Kg	Motor Frame Size
	Output Speed	Ratio	Output Torque	Service Factor	Overhung Load			
4 POLE	181	8.03	757	3.39	34000	K 0 9 3 1 8 . 0 _ M _ - _ - 1 5 . A - -	272	160L
	97	14.94	1408	2.68	34000	1 6 .		
	81	17.93	1700	2.05	34000	1 8 .		
	73	20.03	1893	1.88	34000	2 0 .		
	67	21.61	2040	2.03	34000	2 2 .		
	60	24.14	2280	1.85	34000	2 5 .		
	52	27.78	2621	1.44	34000	2 8 .		
	46	31.67	3005	1.26	34000	3 2 .		
	43	33.47	3162	1.33	34000	3 6 .		
	38	38.16	3596	1.17	34000	4 0 .		

Selected unit's service factor (Fm) = 1.33, therefore unit is acceptable.

6 CHECK OVERHUNG LOADS

If sprocket, gear, etc is mounted on the outputshaft then refer to Overhung Loads Procedure, page 65, and compare with allowable overhung load (N) of selected unit

Allowable overhung load (N) must be equal or more than calculated overhung load (P)

15 kW	N2 R/MIN	i	M2 Nm	Fm	N	UNIT DESIGNATION	Kg	Motor Frame Size
	Output Speed	Ratio	Output Torque	Service Factor	Overhung Load			
4 POLE	181	8.03	757	3.39	34000	K 0 9 3 1 8 . 0 _ M _ - _ - 1 5 . A - -	272	160L
	97	14.94	1408	2.68	34000	1 6 .		
	81	17.93	1700	2.05	34000	1 8 .		
	73	20.03	1893	1.88	34000	2 0 .		
	67	21.61	2040	2.03	34000	2 2 .		
	60	24.14	2280	1.85	34000	2 5 .		
	52	27.78	2621	1.44	34000	2 8 .		
	46	31.67	3005	1.26	34000	3 2 .		
	43	33.47	3162	1.33	34000	3 6 .		
	38	38.16	3596	1.17	34000	4 0 .		

NOTE: If any of the following conditions occur then consult Textron Power Transmission Application Engineers:-

- a) Inertia of the Driven Machine (Referred to motor speed) >10 Inertia of Gear Unit plus Motor
- b) Ambient temperature is above 40°C

0203

OUTPUTBORE OPTIONS,
COLUMN 11 ENTRY

Standard / Inch Hollow Shaft

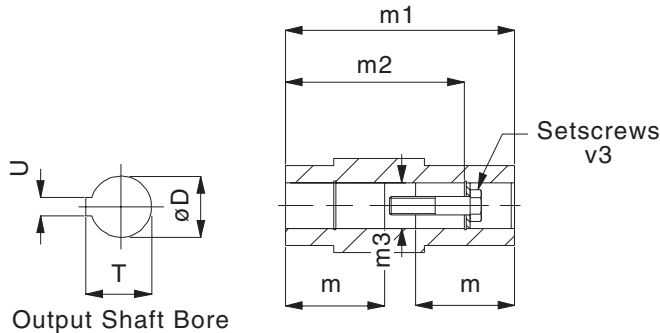

Column 11 Entry

- Standard Hollow Shaft H
- Standard Kibo Shaft * - entry depends on shaft diameter see page 84
- Standard Taper Release * W on Left V on Right
- Standard Shrink Disc * X on Left Y on Right
- Inch Hollow Shaft A
- Inch Kibo Shaft * - entry depends on shaft diameter contact TPT
- Inch Taper Release * Z on Left S on Right
- Inch Shrink Disc * M on Left U on Right

* See pages 83 - 87 for dimensions of these shaft options

SIZE OF UNIT	TYPE OF BORE	COLUMN 11 ENTRY	DIMENSIONS IN MM (Inch bore in inches)							
			øD	m	m1	m2	øm3	T	U	v3
K03	Standard	H	30.021 / 30.000	52.5	120	105	30.3	33.5	8	M10x50L
	Inch	A	1.251" / 1.250"	2.07"	4.724"	4.13"	1.26"	1.377"	0.250"	3/8" UNF x 2" LONG
K04	Standard	H	35.025 / 35.000	66	150	132	35.3	38.5	10	M12x55L
	Inch	A	1.376" / 1.375"	2.60"	5.906"	5.12"	1.38"	1.525"	0.3125"	1/2" UNF x 2 1/4" LONG
K05	Standard	H	40.025 / 40.000	73	166	142	40.3	43.5	12	M16x70L
	Inch	A	1.501" / 1.500"	2.87"	6.535"	5.59"	1.51"	1.675"	0.375"	5/8" UNF x 2 3/4" LONG
K06	Standard	H	40.025 / 40.000	80	180	156	40.3	43.5	12	M16x70L
	Inch	A	1.501" / 1.500"	3.15"	7.087"	6.14"	1.51"	1.675"	0.375"	5/8" UNF x 2 3/4" LONG
K07	Standard	H	50.025 / 50.000	92.5	210	183	50.5	54	14	M16x70L
	Inch	A	2.001" / 2.000"	3.64"	8.268"	7.20"	2.02"	2.230"	0.500"	5/8" UNF x 2 3/4" LONG
K08	Standard	H	60.030 / 60.000	105	240	210	60.5	64.5	18	M20x80L
	Inch	A	2.3762" / 2.3750"	4.134"	9.449"	8.268"	2.382"	2.656"	0.625"	3/4" - 16 UNF x 3 1/4" LONG
K09	Standard	H	70.030 / 70.000	132.5	300	270	70.5	75	20	M20x80L
	Inch	A	2.7512" / 2.7500"	5.217"	11.811"	10.630"	2.772"	3.037"	0.625"	3/4" - 16 UNF x 3 1/4" LONG
K10	Standard	H	80.030 / 80.000	155	350	313	80.5	85.5	22	M20x80L
	Inch	A	3.2514" / 3.2500"	6.102"	13.780"	12.323"	3.268"	3.591"	0.750"	3/4" - 16 UNF x 3 1/4" LONG
K12	Standard	H	100.035 / 100.000	180	410	373	100.5	106.5	28	M24x110L
	Inch	A	4.0014" / 4.0000"	7.087"	16.142"	14.685"	4.020"	4.446"	1.000"	1" - 12 UNF x 4 1/2" LONG

0106

OUTPUTSHAFT OPTIONS.
COLUMN 11 ENTRY

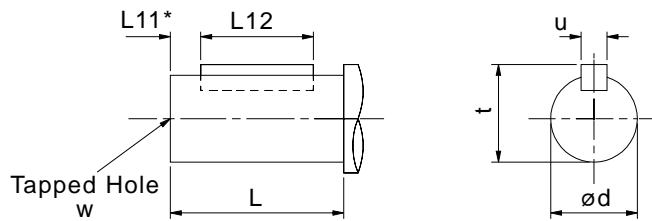

Column 11 Entry

- Standard Single Extension C on Left E on Right
- Standard Double Extension D
- Std Extended Shaft for Flange Mounted Units F
- Inch Single Extension N on Left B on Right
- Inch Double Extension P
- Inch Extended Shaft for Flange Mount Units G

SIZE OF UNIT	TYPE OF OUTPUT SHAFT	COLUMN 11 ENTRY	DIMENSIONS IN MM (Inch shaft in inches)						
			ød	L	L11	L12	t	u	w
K03	Standard Single Ext.	C / E / F	25.015 / 25.002	47	3	40	28	8	M10 x 1.5 x 22 Deep
	Standard Double Ext.	D	25.015 / 25.002	47	3	40	28	8	M10 x 1.5 x 22 Deep
	Inch Single Ext.	N / B / G	1.0000" / 0.9995"	1.85"	*	1.44"	1.106"	0.25"	3/8 UNF x 0.75" Deep
	Inch Double Ext.	P	1.0000" / 0.9995"	1.85"	*	1.44"	1.106"	0.25"	3/8 UNF x 0.75" Deep
K04	Standard Single Ext.	C / E / F	30.015 / 30.002	56	3	50	33	8	M12 x 1.75 x 28 Deep
	Standard Double Ext.	D	30.015 / 30.002	56	3	50	33	8	M12 x 1.75 x 28 Deep
	Inch Single Ext.	N / B / G	1.2500" / 1.2495"	2.20"	*	2"	1.359"	0.25"	1/2 UNF x 1.13" Deep
	Inch Double Ext.	P	1.2500" / 1.2495"	2.20"	*	2"	1.359"	0.25"	1/2 UNF x 1.13" Deep
K05	Standard Single Ext.	C / E / F	35.018 / 35.002	66	3	60	38	10	M16 x 2 x 36 Deep
	Standard Double Ext.	D	35.018 / 35.002	66	3	60	38	10	M16 x 2 x 36 Deep
	Inch Single Ext.	N / B / G	1.3750" / 1.3745"	2.60"	*	2.375"	1.507"	0.3125"	5/8 UNF x 1.5" Deep
	Inch Double Ext.	P	1.3750" / 1.3745"	2.60"	*	2.375"	1.507"	0.3125"	5/8 UNF x 1.5" Deep
K06	Standard Single Ext.	C / E / F	40.018 / 40.002	76	3	70	43	12	M16 x 2 x 36 Deep
	Standard Double Ext.	D	39.991 / 39.975	76	3	70	43	12	M16 x 2 x 36 Deep
	Inch Single Ext.	N / B / G	1.625" / 1.624"	3.00"	*	2.375"	1.784"	0.375"	5/8 UNF x 1.5" Deep
	Inch Double Ext.	P	1.4996" / 1.4990"	3.00"	*	2.375"	1.664"	0.375"	5/8 UNF x 1.5" Deep
K07	Standard Single Ext.	C / E / F	50.018 / 50.002	95	3	80	53.5	14	M16 x 2 x 36 Deep
	Standard Double Ext.	D	49.991 / 49.975	95	3	80	53.5	14	M16 x 2 x 36 Deep
	Inch Single Ext.	N / B / G	2.000" / 1.999"	3.74"	*	2.75"	2.228"	0.50"	5/8 UNF x 1.5" Deep
	Inch Double Ext.	P	2.000" / 1.999"	3.74"	*	2.75"	2.228"	0.50"	5/8 UNF x 1.5" Deep
K08	Standard Single Ext.	C / E / F	60.030 / 60.011	114	3	100	64	18	M20 x 2.5 42 Deep
	Standard Double Ext.	D	59.990 / 59.971	114	3	100	64	18	M20 x 2.5 42 Deep
	Inch Single Ext.	N / B / G	2.3750" / 2.3740"	4.488"	*	3.6875"	2.65"	0.625"	3/4" 16 UNF x 1.65 Deep
	Inch Double Ext.	P	2.3746" / 2.3739"	4.488"	*	3.6875"	2.65"	0.625"	3/4" 16 UNF x 42 Deep
K09	Standard Single Ext.	C / E / F	70.030 / 70.011	135	3	110	74.5	20	M20 x 2.5 x 42 Deep
	Standard Double Ext.	D	69.990 / 69.971	135	3	110	74.5	20	M20 x 2.5 x 42 Deep
	Inch Single Ext.	N / B / G	2.875" / 2.874"	5.315"	*	4.625"	3.20"	0.750"	3/4" 16 UNF x 1.65 Deep
	Inch Double Ext.	P	2.625" / 2.624"	5.315"	*	3.6875"	3.03"	0.625"	3/4" 16 UNF x 42 Deep
K10	Standard Single Ext.	C / E / F	90.035 / 90.013	172	5	140	95	25	M20 x 2.5 x 42 Deep
	Standard Double Ext.	D	75.030 / 75.011	163	5	110	79.5	20	M20 x 2.5 x 42 Deep
	Inch Single Ext.	N / B / G	3.625" / 3.624"	6.772"	*	5.9375"	4.01"	0.875"	3/4" 16 UNF x 1.65 Deep
	Inch Double Ext.	P	3.125" / 3.124"	6.417"	*	4.625"	3.45"	0.750"	3/4" 16 UNF x 42 Deep
K12	Standard Single Ext.	C / E / F	110.035 / 110.013	213	5	180	116	28	M24 x 3 x 55 Deep
	Standard Double Ext.	D	95.035 / 95.013	200	5	140	100	25	M20 x 2.5 x 42 Deep
	Inch Single Ext.	N / B / G	4.375" / 4.374"	8.386"	*	6.500"	4.81"	1.000"	1" 12 UNF x 2.17 Deep
	Inch Double Ext.	P	3.875" / 3.874"	7.874"	*	6.500"	4.31"	1.000"	1" 12 UNF x 55 Deep

* Inch shaft has an open ended keyway, therefore no 'L11' dimension is required

MOTOR ADAPTORS IEC & NEMA

0205

TRIPLE REDUCTION UNITS

IEC Flanges B14 - Column 12 Entry For Unit Types Column 10 Entries G, H and M Only

MOTOR FRAME / FLANGE	UNIT SIZE, NUMBER OF REDUCTIONS, REVISION NUMBER										
	RATIO COVERAGE	K0332		K0432		K0532		K0632		K0732	
		8.0 - 20.	25. - 125	8.0 - 32.	36. - 125	8.0 - 25.	28. - 125	8.0 - 25.	28. - 125	8.0 - 20.	25. - 125
71	COLUMN 12	H	H	-	H	-	-	-	-	-	-
80		B	K	B	K	-	G	-	G	-	G
90		D	R	D	R	-	J	-	J	-	J
100		-	-	-	-	B	L	B	L	B	L
112		-	-	-	-	B	L	B	L	B	L
132		-	-	-	-	-	-	-	-	D	N

IEC Flanges B5 - Column 12 Entry For Unit Types Column 10 Entries G, H and M Only

MOTOR FRAME / FLANGE	UNIT SIZE, NUMBER OF REDUCTIONS, REVISION NUMBER																			
	RATIO COVERAGE	K0332		K0432		K0532		K0632		K0732		K0832		K0931		K1031		K1231		
		8.0 - 20.	25. - 125	8.0 - 32.	36. - 125	8.0 - 25.	28. - 125	8.0 - 25.	28. - 125	8.0 - 20.	25. - 125	8.0 - 32.	36. - 125	8.0 - 40.	45. - 160	8.0 - 36.	40. - 160	8.0 - 40.	45. - 100	112 - 160
63	COLUMN 12 ENTRY	F	F	-	F	-	V	-	V	-	-	-	-	-	-	-	-	-	-	
71		G	G	-	G	-	D	-	D	-	-	-	-	-	-	-	-	-	-	
80		A	J	A	J	W	F	W	F	-	F	-	D	-	E	-	-	-	-	
90		C	Q	C	Q	Y	H	Y	H	-	H	-	E	-	F	-	-	-	-	
100		-	-	-	-	A	K	A	K	A	K	A	F	-	G	-	E	-	G	N
112		-	-	-	-	A	K	A	K	A	K	A	F	-	G	-	E	-	G	N
132		-	-	-	-	N	P	N	P	C	M	B	G	-	H	-	F	-	H	P
160		-	-	-	-	-	-	-	-	E	P	C	H	A	J	A	G	A	J	Q
180		-	-	-	-	-	-	-	-	-	-	-	-	B	K	B	H	B	K	R
200		-	-	-	-	-	-	-	-	-	-	-	-	C	L	C	J	C	L	S
225		-	-	-	-	-	-	-	-	-	-	-	-	D	M	D	K	D	M	T
250		-	-	-	-	-	-	-	-	-	-	-	-	-	-	-	-	E	U	-
280	-	-	-	-	-	-	-	-	-	-	-	-	-	-	-	-	F	W	-	

NEMA Flanges C Face - Column 12 Entry For Unit Types Column 10 Entries A, E and N Only

MOTOR FRAME / FLANGE	UNIT SIZE, NUMBER OF REDUCTIONS, REVISION NUMBER																			
	RATIO	K0332		K0432		K0532		K0632		K0732		K0832		K0931		K1031		K1231		
		8.0 - 20.	25. - 125	8.0 - 32.	36. - 125	8.0 - 25.	28. - 125	8.0 - 25.	28. - 125	8.0 - 20.	25. - 125	8.0 - 32.	36. - 125	8.0 - 40.	45. - 160	8.0 - 36.	40. - 160	8.0 - 40.	45. - 100	112 - 160
56c	COLUMN 12 ENTRY	T	U	T	U	-	Q	-	Q	-	Q	-	M	-	-	-	-	-	-	
143/145TC		V	W	V	W	-	R	-	R	-	R	-	N	-	-	-	-	-	-	
182/184TC		X	-	X	-	S	T	S	T	S	T	J	P	-	S	-	P	-	N	A
213/215TC		-	-	-	-	U	-	U	-	U	V	K	Q	-	T	-	Q	-	P	B
254/256TC		-	-	-	-	-	-	-	-	W	-	L	U	P	U	L	R	F	Q	C
284/286TC		-	-	-	-	-	-	-	-	-	-	-	-	Q	V	M	S	G	R	D
324/326TC		-	-	-	-	-	-	-	-	-	-	-	-	R	W	N	T	H	S	E
364/365TC		-	-	-	-	-	-	-	-	-	-	-	-	-	-	-	-	J	T	-
404/405TC		-	-	-	-	-	-	-	-	-	-	-	-	-	-	-	-	K	U	-

MOTOR ADAPTORS IEC & NEMA

0205

QUINTUPLE REDUCTION UNITS

IEC Flanges B14 - Column 12 Entry For Unit Types Column 10 Entries G, H and M Only

MOTOR FRAME / FLANGE	UNIT SIZE, NUMBER OF REDUCTIONS, REVISION NUMBER																		
	K0352		K0452		K0552		K0652		K0752		K0852		K0951		K1051		K1251		
	RATIO COVERAGE		RATIO COVERAGE		RATIO COVERAGE		RATIO COVERAGE		RATIO COVERAGE		RATIO COVERAGE		RATIO COVERAGE		RATIO COVERAGE		RATIO COVERAGE		
71	H	H	H	H	-	H	-	H	-	H	-	-	-	-	-	-	-	-	
80	B	K	B	K	B	K	B	K	B	K	-	G	-	G	-	G	-	G	
90	D	R	D	R	D	R	D	R	D	R	-	J	-	J	-	J	-	J	
100	-	-	-	-	-	-	-	-	-	-	B	L	B	L	B	L	B	L	
112	-	-	-	-	-	-	-	-	-	-	B	L	B	L	B	L	B	L	
132	-	-	-	-	-	-	-	-	-	-	-	-	-	-	-	D	N	D	N

IEC Flanges B5 - Column 12 Entry For Unit Types Column 10 Entries G, H and M Only

MOTOR FRAME / FLANGE	UNIT SIZE, NUMBER OF REDUCTIONS, REVISION NUMBER																		
	K0352		K0452		K0552		K0652		K0752		K0852		K0951		K1051		K1251		
	RATIO COVERAGE		RATIO COVERAGE		RATIO COVERAGE		RATIO COVERAGE		RATIO COVERAGE		RATIO COVERAGE		RATIO COVERAGE		RATIO COVERAGE		RATIO COVERAGE		
63	F	F	F	F	-	F	-	F	-	F	-	V	-	V	-	-	-	-	
71	G	G	G	G	-	G	-	G	-	G	-	D	-	D	-	-	-	-	
80	A	J	A	J	A	J	A	J	A	J	W	F	W	F	-	F	-	F	
90	C	Q	C	Q	C	Q	C	Q	C	Q	Y	H	Y	H	-	H	-	H	
100	-	-	-	-	-	-	-	-	-	-	A	K	A	K	A	K	A	K	
112	-	-	-	-	-	-	-	-	-	-	A	K	A	K	A	K	A	K	
132	-	-	-	-	-	-	-	-	-	-	N	P	N	P	C	M	C	M	
160	-	-	-	-	-	-	-	-	-	-	-	-	-	-	-	E	P	E	P

NEMA Flanges C Face - Column 12 Entry For Unit Types Column 10 Entries A, E and N Only

MOTOR FRAME / FLANGE	UNIT SIZE, NUMBER OF REDUCTIONS, REVISION NUMBER																	
	K0352		K0452		K0552		K0652		K0752		K0852		K0951		K1051		K1251	
	RATIO		RATIO		RATIO		RATIO		RATIO		RATIO		RATIO		RATIO		RATIO	
56c	T	U	T	U	T	U	T	U	T	U	-	Q	-	Q	-	Q	-	Q
143/145TC	V	W	V	W	V	W	V	W	V	W	-	R	-	R	-	R	-	R
182/184TC	X	-	X	-	X	-	X	-	X	-	S	T	S	T	S	T	S	T
213/215TC	-	-	-	-	-	-	-	-	-	-	U	-	U	-	U	V	U	V
254/256TC	-	-	-	-	-	-	-	-	-	-	-	-	-	-	W	-	W	-

0106

Gear units 03, 04, 05, 06 & 07 will be supplied filled with a quantity of EP mineral oil (TPT Grade 6E) appropriate to the intended mounting position. However if, as requested, the unit is supplied without lubricant then the oil quantity required is obtained from Table 2. Gear units 08, 09, 10 & 12 are supplied without lubricant. Recommended lubricants are listed in the Approved Lubricant scheme booklet.

LUBRICATION CHANGE PERIOD

- Sizes 03, 04 and 05 are filled for life.
- All other sizes of Series K will require an oil change:
 - 10,000 hours for mineral oil
 - 20,000 hours for synthetic oil

TEMPERATURE LIMITATIONS

The standard lubricant is suitable for operation in ambient temperatures of 0° to 35°C, outside of this consult Table 1 or Textron Power Transmission Application Engineers.

TABLE 1 OIL GRADES

LUBRICANT	AMBIENT TEMPERATURE RANGE		
	-5°C to 20°C (type E) -30°C to 20°C (type H)	0°C to 35°C	20°C to 50°C
EP Mineral Oil (type E)	5E (VG 220)	6E (VG 320)	7E (VG 460)
Polyalphaolefin based Synthetic (type H)	5H (VG 220)	5H (VG 220)	6H (VG 320)

TABLE 2 LUBRICANT QUANTITY (Litres) TRIPLE REDUCTION

K03, K04 & K05 - fill with correct quantity of lubricant

K06, K07, K08, K09, K10 & K12 - fill gearbox until oil escapes from level plug hole

TRIPLE REDUCTION										
Unit Size	K0332	K0432	K0532	K0632	K0732	K0832	K0931	K1031	K1231	
MOUNTING POSITION	1	0.8	1.0	1.5	1.7	3.5	4.5	8.8	14	22
	2	1.0	1.3	1.85	2.8	5.8	8.0	15	24	36
	3	1.0	1.3	1.85	2.8	5.8	8.0	15	24	36
	4	1.3	1.7	2.4	3.3	6.8	9.1	17.5	28.6	41
	5	1.7	2.2	3.1	4.2	8.7	10.4	20.9	33	49
	6	1.0	1.3	1.9	2.9	5.8	9.1	16.3	25.6	35.9

TABLE 3 LUBRICANT QUANTITY (Litres) QUINTUPLE REDUCTION

QUINTUPLE REDUCTION											
Unit Size	K0352		K0452		K0552		K0652		K0752		
	* Primary	Secondary	* Primary	Secondary	* Primary	Secondary	* Primary	Secondary	* Primary	Secondary	
	M0122	K0332	M0122	K0432	M0322	K0532	M0322	K0632	M0322	K0732	
MOUNTING POSITION	1	0.7	0.8	0.7	1.0	0.8	1.5	0.8	1.7	0.8	3.5
	2	0.7	1.0	0.7	1.3	0.8	1.85	0.8	2.8	0.8	5.8
	3	0.7	1.0	0.7	1.3	0.8	1.85	0.8	2.8	0.8	5.8
	4	0.7	1.3	0.7	1.7	0.8	2.4	0.8	3.3	0.8	9.1
	5	1.0	1.7	1.0	2.1	1.4	3.1	1.4	4.2	1.4	10.4
	6	1.1	1.0	1.1	1.3	1.5	1.9	1.5	2.9	1.5	9.1

QUINTUPLE REDUCTION									
Unit Size	K0852		K0951		K1051		K1251		
	* Primary	Secondary	* Primary	Secondary	* Primary	Secondary	* Primary	Secondary	
	M0522	K0832	M0522	K0931	M0722	K1031	M0722	K1231	
MOUNTING POSITION	1	1.6	4.5	1.6	8.8	2.8	14.0	2.8	22.0
	2	1.6	9.3	1.6	15.0	2.8	24.0	2.8	36.0
	3	1.6	6.2	1.6	15.0	2.8	24.0	2.8	36.0
	4	1.6	9.1	1.6	17.5	2.8	28.6	2.8	41.0
	5	1.9	10.4	1.9	20.9	3.2	33.0	3.2	49.0
	6	2.5	9.1	2.5	16.3	4.9	25.6	4.9	35.9

* NOTE: Primary units filled with Textron Power Transmission Grade 6E lubricant suitable for all ambient temperatures between 0°C and 35°C

0106

COLUMN 13 ENTRY

Enter for units with no oil fill

Base Mounted Units

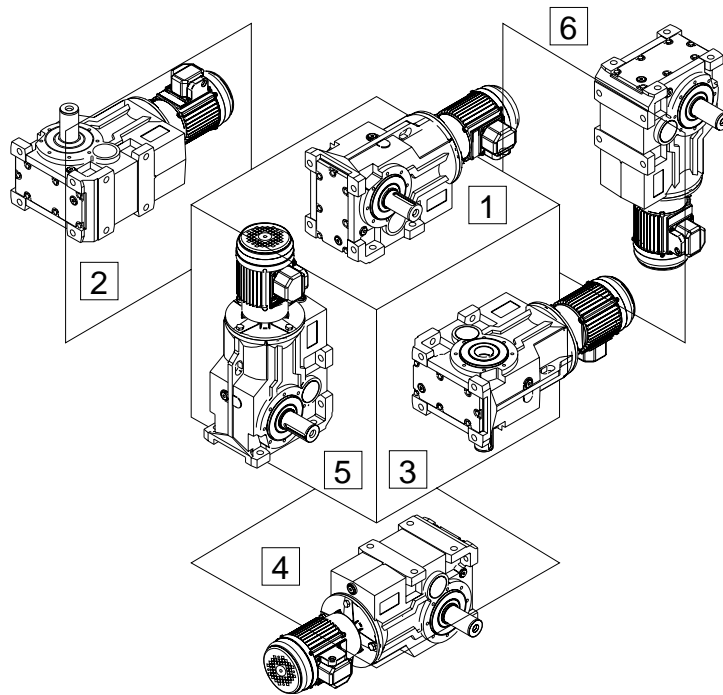

Flange Mounted Units

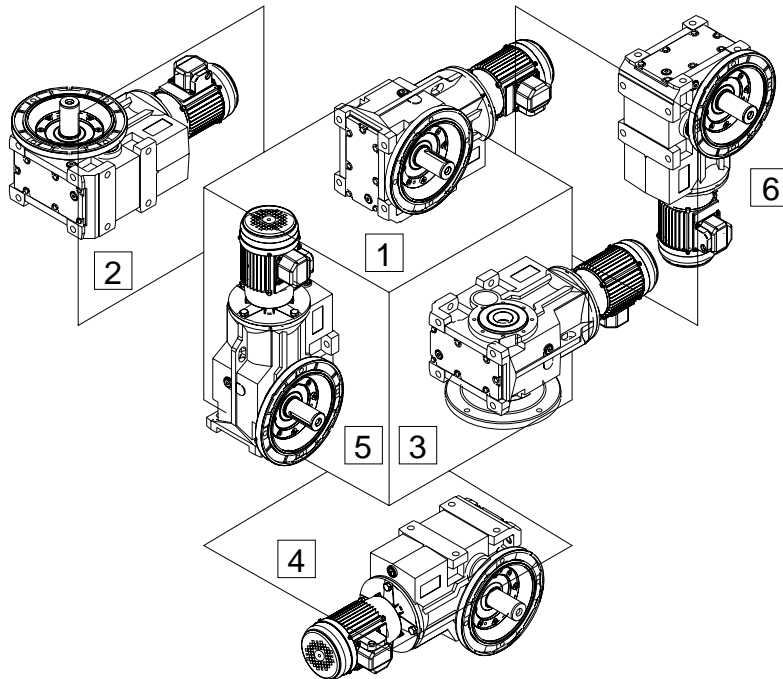

MOUNTING POSITIONS - SHOWN AS MOTORISED - APPLIES ALSO FOR REDUCERS

COLUMN 14 ENTRY

ALL MOTORS

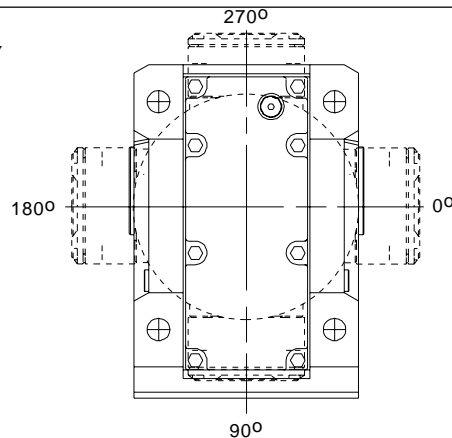

Column 14 Entry	Terminal Box Position
A	0°
B	90°
C	180°
D	270°
-	Reducer or no motor fitted

0203

Column 9 Entry	Left	Right
Unit Version Std Unit with Output Flange	F	H
Std Unit with Torque Bracket	T	Q

Column 11 Entry	Metric		Inch	
	Left	Right	Left	Right
Single Output Shaft	C	E	N	B
Double Output Shaft	D		P	

Hollow Shaft	H	A		
Kibo	Column 11 entry depends on shaft bore diameter, please see page 84 	Column 11 entry depends on shaft bore diameter, please contact Textron Power Transmission for inch Kibo options. 		
Taper Release	W Note: non-standard handing, please contact Textron Power Transmission	V Driven Machine Side	Z Note: non-standard handing, please contact Textron Power Transmission	S Driven Machine Side
Shrink Disc	X Note: non-standard handing, please contact Textron Power Transmission	Y Driven Machine Side	M Note: non-standard handing, please contact Textron Power Transmission	U Driven Machine Side

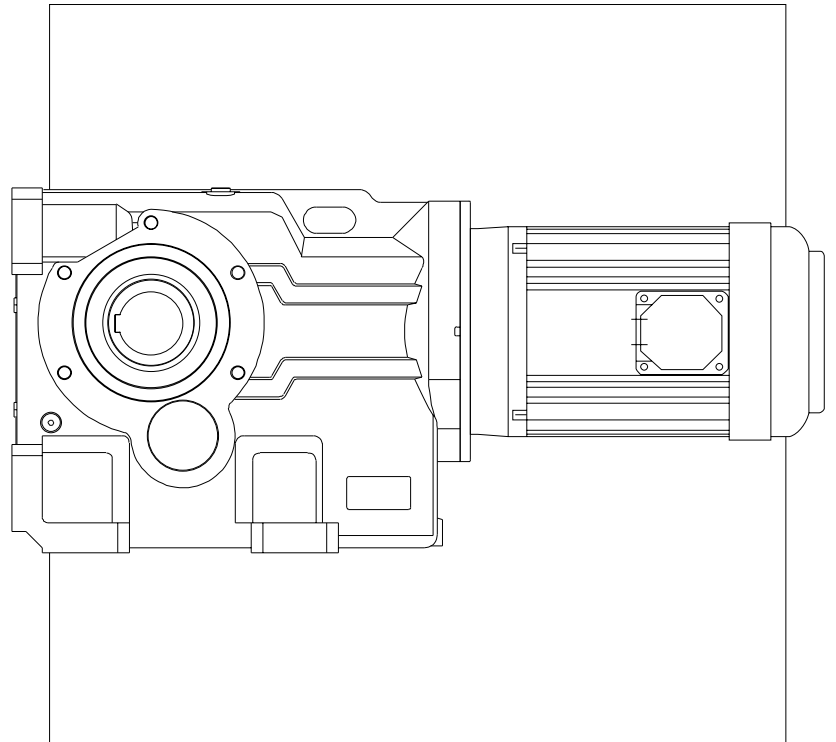

MOTORISED SERIES K

TEXTRON POWER TRANSMISSION

MOTOR PERFORMANCE DATA

0205

TEFC, CLASS F, 40°C AMBIENT TEMP. AS; BS DESIGN B CONTINUOUS DUTY S.F. 1.0, 380, 400, 415 50HZ

ALUMINIUM MOTORS TYPICAL PERFORMANCE (400 V)

kW	Full Load (RPM)	Frame No.	Current at 400V (Amps)	Efficiency		Power Factor		D.O.L. Start Current (% FLT)	D.O.L. Start Torque (% FLT)	Pull Up Torque (% FLT)	Pull Out Torque (% FLT)	Rotor Inertia GD ² (kg,m ²)	Approx Weight (kg)
				100% Load (%)	75% Load (%)	100% Load (Cos ϕ)	75% Load (Cos ϕ)						
0.12	2790	63	0.44	61.2	59.0	0.65	0.58	490	200	170	280	0.0020	4.5
	1360	63	0.45	60.5	60.0	0.62	0.51	450	200	180	260	0.0022	4.5
	870	63	0.59	52.0	51.0	0.57	0.49	380	175	158	200	0.0029	4.5
0.18	2800	63	0.59	64.0	61.5	0.70	0.62	490	200	170	280	0.0021	4.5
	1370	63	0.64	62.0	62.4	0.64	0.59	430	200	180	260	0.0028	4.5
	900	71	0.68	60.0	61.9	0.60	0.51	380	175	158	200	0.0053	6.5
0.25	2800	63	0.76	66.2	64.6	0.75	0.67	550	200	170	280	0.0023	4.5
	1400	71	0.82	65.5	64.0	0.67	0.59	490	200	180	250	0.0034	6.5
	900	71	0.90	63.0	63.3	0.61	0.53	400	175	158	210	0.0064	6.5
0.37	2800	71	0.92	71.0	69.0	0.83	0.76	670	200	170	280	0.0023	6.5
	1400	71	1.13	68.5	66.2	0.70	0.61	530	200	180	250	0.0045	6.5
	920	80A	1.29	66.7	65.2	0.62	0.58	450	175	158	210	0.0081	9.5
0.55	2780	71	1.35	74.3	72.8	0.80	0.74	680	200	170	260	0.0023	6.5
	1420	80A	1.56	73.5	72.0	0.72	0.64	590	200	180	250	0.0067	9.5
	920	80B	1.76	69.5	67.5	0.65	0.58	490	175	158	220	0.011	11
0.75	2830	80A	1.66	76.5	77.0	0.85	0.80	690	200	170	250	0.0045	9.5
	1415	80A	1.97	75.3	74.3	0.73	0.67	580	200	180	250	0.0081	9.5
	920	90S	2.16	73.8	72.3	0.67	0.60	510	175	158	210	0.016	13.5
1.1	2820	80B	2.36	79.0	79.5	0.85	0.81	795	200	170	250	0.0054	11
	1410	90S	2.70	77.8	76.8	0.76	0.69	640	200	180	240	0.013	13.5
	925	90L	3.05	74.0	76.8	0.67	0.60	520	175	158	220	0.022	14.5
1.5	2860	90S	3.18	80.0	80.5	0.85	0.82	755	200	170	270	0.0099	13.5
	1420	90L	3.50	80.0	78.2	0.79	0.71	650	200	180	240	0.016	14.5
	925	100L	3.88	79.0	78.2	0.70	0.64	590	175	158	210	0.03	24
2.2	2860	90L	4.59	82.3	82.8	0.84	0.82	795	200	170	270	0.014	14.5
	1420	90LA	5.03	81.0	81.2	0.78	0.72	760	200	180	240	0.022	20
	1425	100L	4.89	82.3	81.6	0.79	0.73	700	200	180	240	0.03	24
	950	112M	5.40	81.6	80.8	0.72	0.65	640	175	158	220	0.054	31
3	2870	100L	5.94	83.8	84.3	0.87	0.85	770	200	170	270	0.021	24
	1425	100L	6.51	83.2	83.0	0.80	0.74	700	200	180	240	0.042	24
	955	132SA	6.74	83.2	83.0	0.77	0.72	680	175	158	230	0.14	48
4	2880	112M	7.7	85.3	85.8	0.88	0.86	830	200	160	260	0.042	31
	1435	112M	8.45	85.3	84.0	0.80	0.75	760	200	160	240	0.059	31
	960	132M	9.19	84.5	83.0	0.75	0.68	685	175	158	240	0.16	52
5.5	2900	132SA	10.5	86.7	86.2	0.88	0.83	830	200	170	250	0.059	48
	1430	112MA	11.7	85.7	85.5	0.79	0.75	820	200	180	230	0.085	45
	1440	132SA	11.5	86.7	85.5	0.80	0.75	760	200	180	230	0.095	48
	960	132M	12.0	85.5	84.8	0.77	0.72	720	175	158	230	0.21	52
7.5	2900	132SB	14.2	87.9	87.9	0.87	0.85	765	200	170	240	0.07	53
	1445	132M	14.9	87.9	87.9	0.83	0.78	730	200	180	230	0.13	52
	960	160MA	16.0	86.5	84.7	0.79	0.73	680	175	158	230	0.37	81
9.2	1440	132MA	18.15	87.7	87.9	0.84	0.80	760	200	180	230	0.19	78
11	2900	160MA	20.5	88.5	88.0	0.88	0.86	795	200	170	230	0.15	81
	1440	132MB	21.1	88.4	88.1	0.85	0.82	820	200	180	230	0.22	88
	1450	160MA	20.7	88.5	88.5	0.87	0.83	790	200	180	230	0.29	81
	965	160L	22.3	88.0	88.0	0.81	0.76	730	175	158	220	0.54	95
15	2910	160MB	26.6	90.5	90.5	0.90	0.89	820	200	170	230	0.20	78
	1455	160L	27.9	90.5	90.5	0.86	0.81	780	200	180	220	0.34	95
18.5	2915	160L	32.6	91.0	91.0	0.90	0.89	775	200	170	230	0.24	95

MOTOR PERFORMANCE DATA

0104

TEFC, CLASS F, 40. AMBIENT TEMP. AS; BS DESIGN B CONTINUOUS DUTY S.F. 1.0, 380, 400, 415 50HZ

CAST IRON MOTORS TYPICAL PERFORMANCE (400 V)

kW	Full Load (RPM)	Frame No.	Current at 400V (Amps)	Efficiency		Power Factor		D.O.L. Start Current (% FLT)	D.O.L. Start Torque (% FLT)	Pull Up Torque (% FLT)	Pull Out Torque (% FLT)	Rotor Inertia GD ² (kg,m ²)	Approx Weight (kg)
				100% Load (%)	75% Load (%)	100% Load (Cos ϕ)	75% Load (Cos ϕ)						
4	723	D160M	9.8	85.9	85.7	75.5	67.9	532	198	188	283	0.351	113
5.5	720	D160M	12.9	84.5	84.9	75.5	68.2	575	217	195	331	0.0821	113
7.5	720	D160L	17	86.1	86.9	77.3	70.3	576	216	194	340	0.1141	133
11	730	D180L	24	87.5	87.8	77.4	70.2	657	230	207	297	0.167	181
15	970	D180L	29	89.5	89.8	82.7	77.9	640	213	191	303	0.167	181
	730	D200L	32	89.1	89.2	77.8	71.2	625	186	167	298	0.325	232
18.5	1470	D180M	34	90.5	90.7	89.1	84.7	757	245	220	315	0.135	167
	975	D200L	36	89.9	90.1	84.0	78.7	651	213	191	329	0.302	232
	730	D225S	38	90.1	90.2	77.0	71.0	680	200	180	300	0.481	287
22	2940	D180M	39	90.8	90.6	90.7	88.9	752	252	226	344	0.071	167
	1470	D180L	40	91.3	91.8	88.1	84.2	674	225	202	309	0.136	181
	975	D200L	42	89.9	90.3	84.7	81.1	669	217	195	316	0.347	232
	730	D225M	44	90.6	90.7	77.0	72.2	682	213	191	301	0.531	322
30	2945	D200L	53	91.6	91.3	90.0	87.9	742	266	239	346	0.119	232
	1470	D200L	55	91.9	92.1	88.5	83.4	664	231	207	303	0.245	232
	980	D225M	55	91.7	91.8	85.2	82.6	612	235	211	284	0.525	322
	730	D250M	60	90.8	90.8	82.3	76.8	582	198	178	298	0.809	385
37	2945	D200L	64	92.0	91.3	92.0	89.8	782	248	223	298	0.809	232
	1475	D225S	66	92.4	92.5	87.5	84.9	658	221	198	306	0.39	287
	980	D250M	68	91.5	91.4	86.8	83.1	688	212	190	323	0.807	385
	735	D280S	74	91.5	91.5	79.0	71.0	660	200	180	240	1.381	510
45	2950	D225M	77	92.5	92.4	89.8	87.8	788	275	247	369	0.221	322
	1475	D225M	80	92.5	92.5	88.8	86.2	743	209	188	314	0.45	322
	980	D280S	82	92.5	92.3	86.0	83.0	700	230	207	270	1.334	510
	735	D280M	90	92.0	91.8	79.0	71.0	660	200	180	240	1.721	600
55	2965	D250M	95	93.0	92.1	89.2	86.3	770	195	175	368	0.305	385
	1475	D250M	98	93.0	92.8	88.9	86.0	685	223	200	316	0.64	385
	980	D280M	100	92.8	92.5	86.0	83.0	700	230	207	270	1.598	600
75	2965	D280S	127	93.6	93.0	91.0	89.0	780	220	200	250	0.584	510
	1485	D280S	133	93.8	93.5	87.0	85.0	750	220	200	240	1.045	510
90	2965	D280M	152	93.9	93.3	91.0	89.0	780	220	200	250	0.665	600
	1485	D280M	159	94.2	93.9	87.0	85.0	750	220	200	240	1.396	600

- NOTE.
1. The above are typical values based on test.
 2. Actual load & full voltage starting, According to BS 4999, AS 1359.
 3. Tolerance according to BS4999, AS1359.
 4. Efficiency, power factor, speed and torque are the same for other voltages. Current values vary inversely with voltage.
 5. Data subject to change without notice.

0104

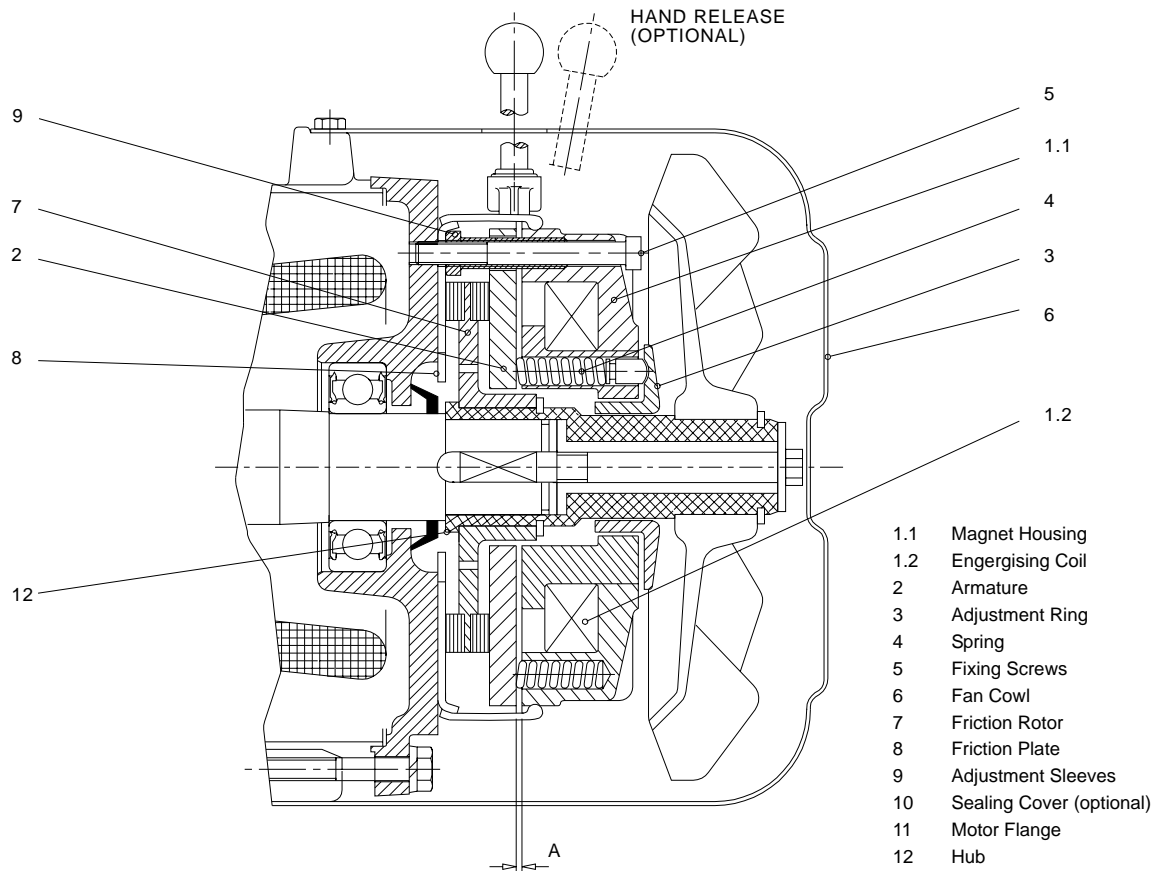

BRAKE MOTORS

Construction and Operating Principle

The magnet housing (1.1) of the spring applied brake contains the permanently fitted energising coil (1.2) with its supply lead protruding from the brake periphery. In the adjustment ring (3) are fitted the pressure springs (4), which push the friction rotor (7) via the armature (2) against the static friction plate (8) and thus against the motor flange (11). The braking effect is achieved thereby. The air gap 'A' is adapted by means of sleeves (9). The air gap 'A' cannot be re-adjusted. It is recommended to replace the friction rotor (7) when it is worn (end of wear). The friction rotor (7) has a star shaped bore (size 10,11 and 14) or a square bore (size 08, 13, 16 and 19) and can thus be glided axially on the hub (12). When applying a DC current to the energising coil (1.2), a magnetic force is induced, compensating the effect of the spring, lifting the armature (2) and thereby releasing the brake. No axial load is applied by the brake to the shaft that is to be decelerated

Condition upon Delivery

The brake motor is supplied ready for use, ie the air gap 'A' is pre-set to the specified value at the factory by means of the sleeves (9). The required nominal torque M_2 is also adjusted at the factory.

MOTOR FRAME SIZE		63	71	80	90	100	112	132S	132M	160
BRAKE SIZE		08	08	10	11	13	14	14	16	19
BRAKE TORQUE (M_2)	Nm	2.5	5	10	20	40	65	65	100	170
COUPLING TIME (t_1)	Ms	18	18	20	30	45	86	86	90	130

For larger frame sizes standard proprietary brake motors are available. For details contact Textron Power Transmission

0205

B14 'C' FACE

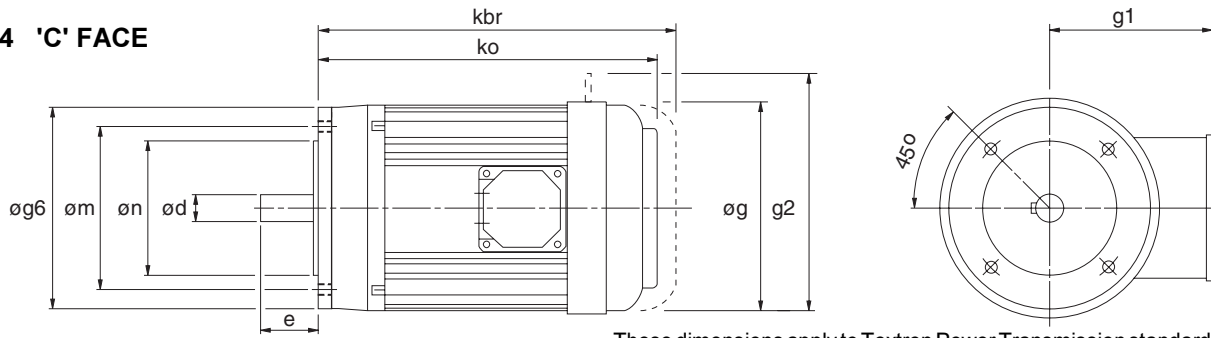

These dimensions apply to Textron Power Transmission standard motors

MOTOR FRAME SIZE	øg6	øm	øn	ød	e	ko	kbr	øg	g1	g2	FIXING BOLTS
71	105	85	70	14	30	220.5	265	138	114	167	4 x M6
80A	120	100	80	19	40	238.5	291	157	124.5	190	4 x M6
80B	120	100	80	19	40	247.5	300	157	124.5	190	4 x M6
90S	140	115	95	24	50	260	312	177	133	218	4 x M8
90L	140	115	95	24	50	275	327	177	133	218	4 x M8
90LA	140	115	95	24	50	284	336	177	133	218	4 x M8
100L	160	130	110	28	60	310	370	197	144	238	4 x M8
112M	160	130	110	28	60	325	399	219	155	238	4 x M8
112MA	160	130	110	28	60	344	419	219	155	238	4 x M8
132SA	200	165	130	38	80	392	475	235	172	288	4 x M10
132M	200	165	130	38	80	412	495	235	172	288	4 x M10
132MA	200	165	130	38	80	436	519	235	172	288	4 x M10
132MB	200	165	130	38	80	472	555	235	172	288	4 x M10

B5 'D' FLANGE

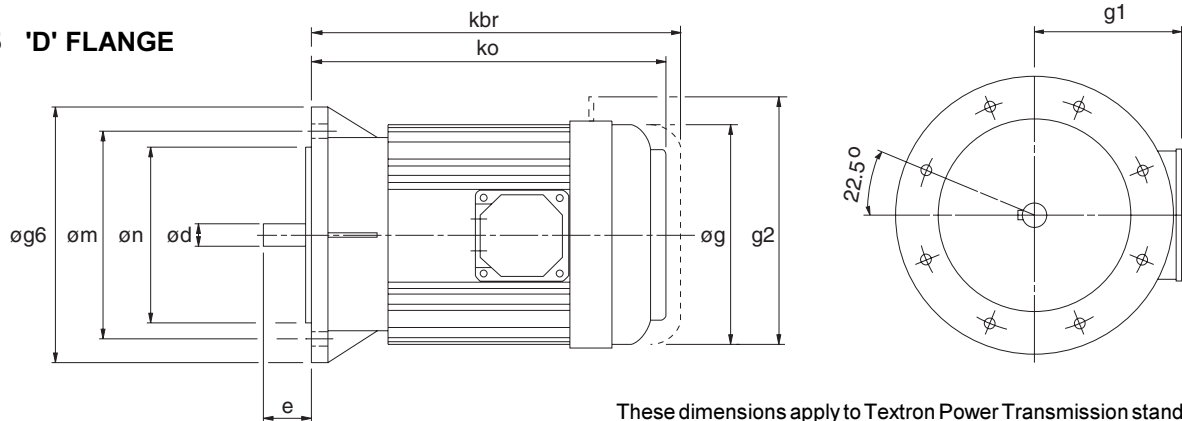

These dimensions apply to Textron Power Transmission standard motors

MOTOR FRAME SIZE	øg6	øm	øn	ød	e	ko	kbr	øg	g1	g2	FIXING BOLTS
63	140	115	95	11	23	218	263	122	107.5	160	4 x M8
71	160	130	110	14	30	220.5	265	138	114	167	4 x M8
80A	200	165	130	19	40	238.5	291	157	124.5	190	4 x M10
80B	200	165	130	19	40	247.5	300	157	124.5	190	4 x M10
90S	200	165	130	24	50	260	312	177	133	218	4 x M10
90L	200	165	130	24	50	275	327	177	133	218	4 x M10
90LA	200	165	130	24	50	284	336	177	133	218	4 x M10
100L	250	215	180	28	60	310	370	197	144	238	4 x M12
112M	250	215	180	28	60	325	399	219	155	238	4 x M12
112MA	250	215	180	28	60	344	419	219	155	238	4 x M12
132SA	300	265	230	38	80	392	475	235	172	288	4 x M12
132M	300	265	230	38	80	412	495	235	172	288	4 x M12
132MA	300	265	230	38	80	436	519	235	172	288	4 x M12
132MB	300	265	230	38	80	472	555	235	172	288	4 x M12
160M	350	300	250	42	110	455	538	273	282	323	4 x M16
160L	350	300	250	42	110	500	583	273	282	323	4 x M16
180M	350	300	250	48	110	557	-	382	307	-	4 x M16
180L	350	300	250	48	110	595	-	382	307	-	4 x M16
200L	400	350	300	55	110	658	-	420	372	-	4 x M16
225S	450	400	350	60	140	671	-	458	427	-	8 x M16
225M	450	400	350	60	140	696	-	458	427	-	8 x M16
250M	550	500	450	65	140	770.5	-	510	490	-	8 x M16
280S	550	500	450	75	140	837	-	576	520	-	8 x M16
280M	550	500	450	75	140	888	-	576	520	-	8 x M16

ADDITIONAL MOTOR FEATURES

0102

ADDITIONAL MOTOR FEATURES - COLUMN 19 ENTRY

Column 19 Entry	Brake Motor	Hand Release on Brake	Forced Ventilation / Constant Blower (TECB)	Thermistors	Special
-					
A	●				
B	●	●			
C			●		
D	●		●		
E	●	●	●		
F				●	
G	●			●	
H	●	●		●	
K			●	●	
L	●		●	●	
M	●	●	●	●	
S					●

Please refer to Textron Power Transmission for details of the following additional motor features

- PGF encoder flange
- Wash down
- Customised brake torque
- Separate brake supply
- Aluminium fan
- Anti Condensation heater
- Bi-metal temperature detectors, Thermostat
- EExEII T3
- Ex nA II T3
- IP56
- IP65
- Metal fan cover
- Rain cowl
- Separate terminal box
- IP55

ADDITIONAL GEARBOX FEATURES

0102

ADDITIONAL GEARBOX FEATURES - COLUMN 20 ENTRY

Column 20 Entry	Double Oil Seals	Oil Level Glass	Motorised Backstop		Special
			CW Rotation	CCW Rotation	
-					
A	●				
B		●			
C	●	●			
D			●		
E	●		●		
F		●	●		
G	●	●	●		
H				●	
I	●			●	
J		●		●	
K	●	●		●	
L					●

Please refer to Textron Power Transmission for details of the following additional gearbox features

- Prime paint only
- Wash down
- BISSC compatible
- Special oil (food compatible, bio-degradable, different viscosities etc)

0205

0.12 kW

4 POLE

6 POLE

NOTE
Other output speeds are available using 2 and 8 pole motors - Consult Textron Power Transmission

N2 R/MIN	i	M2 Nm	Fm	N	Unit Designation	Kg	Motor Size
Output Speed	Ratio	Output Torque	Service Factor	Overhung Load	Column Entry <input type="text" value="1"/> Through <input type="text" value="20"/> Spaces to be filled when entering order	Weight of base mount unit	
163	8.33	6	20.32	4300	K 0 3 3 2 8 . 0 _ M _ _ _ . 1 2 A _ _	20.5	63
121	11.25	9	16.96	4730	1 1 .		
106	12.8	10	15.63	4930	1 2 .		
94	14.5	11	14.46	5130	1 4 .		
73	18.54	15	12.19	5550	1 8 .		
68	19.98	16	11.57	5680	2 0 .		
54	25.23	20	9.77	6000	2 5 .		
48	28.6	23	8.91	6000	2 8 .		
42	32.68	26	8.13	6000	3 2 .		
37	36.35	29	7.5	6000	3 6 .		
34	40.08	32	6.9	6000	4 0 .		
31	44.11	35	6.27	6000	4 5 .		
26	51.68	41	5.36	6000	5 0 .		
22	62	50	4.47	6000	6 3 .		
19	72.27	58	3.85	6000	7 1 .		
17	80.3	64	3.46	6000	8 0 .		
14	96.7	78	2.38	6000	1 0 0		
12	110.83	89	1.78	6000	1 1 2		
11	125.96	101	1.54	6000	1 2 5		
11	127.79	99	2.27	6000	K 0 3 5 2 1 2 5 _ M _ _ _ . 1 2 A _ _	29.5	63
9.4	145.34	112	1.99	6000	1 4 0		
8.3	164.66	127	1.76	6000	1 6 0		
6.5	210.58	163	1.37	6000	2 0 0		
6	226.95	176	1.27	6000	2 5 0		
4.7	286.52	222	1.01	6000	2 8 0		
4.2	324.82	252	0.89	6000	3 2 0		
9.2	147.98	115	3.83	6000	K 0 4 5 2 1 4 0 _ M _ _ _ . 1 2 A _ _	34.5	63
8	170.21	131	3.35	6000	1 6 0		
6.8	199.9	155	2.83	6000	2 0 0		
5.3	257.59	200	2.2	6000	2 5 0		
4.8	284.33	219	2.01	6000	2 8 0		
4.2	322.4	251	1.75	6000	3 2 0		
3.8	355.03	277	1.59	6000	3 6 0		
3.3	407.03	318	1.39	6000	4 0 0		
3	448.23	349	1.26	6000	4 5 0		
2.7	508.14	396	1.11	6000	5 0 0		
2.3	580.67	453	0.97	6000	5 6 0		
2.1	645.94	503	0.88	6000	6 3 0		
104	8.33	10	14.12	4860	K 0 3 3 2 8 . 0 _ M _ _ _ . 1 2 C _ _	20.5	63
77	11.25	14	11.86	5330	1 1 .		
68	12.8	16	10.88	5550	1 2 .		
60	14.5	18	10.04	5770	1 4 .		
47	18.54	23	8.46	6000	1 8 .		
44	19.98	25	8.01	6000	2 0 .		
34	25.23	32	6.8	6000	2 5 .		
30	28.6	36	6.17	6000	2 8 .		
27	32.68	41	5.4	6000	3 2 .		
24	36.35	46	4.87	6000	3 6 .		
22	40.08	51	4.41	6000	4 0 .		
20	44.11	56	4.01	6000	4 5 .		
17	51.68	65	3.43	6000	5 0 .		
14	62	78	2.86	6000	6 3 .		
12	72.27	91	2.45	6000	7 1 .		
11	80.3	101	2.21	6000	8 0 .		
9	96.7	122	1.52	6000	1 0 0		
7.8	110.83	139	1.14	6000	1 1 2		
6.9	125.96	158	0.99	6000	1 2 5		
6.8	127.79	156	1.44	6000	K 0 3 5 2 1 2 5 _ M _ _ _ . 1 2 C _ _	29.5	63
6	145.34	177	1.26	6000	1 4 0		
5.3	164.66	201	1.12	6000	1 6 0		
4.1	210.58	257	0.87	6000	2 0 0		
3.8	226.95	277	0.81	6000	2 5 0		
8.2	105.69	133	3.25	6000	K 0 4 3 2 1 1 2 _ M _ _ _ . 1 2 C _ _	26.5	63
7.2	120.15	151	2.92	6000	1 2 5		
6.5	134.38	164	2.68	6000	K 0 4 5 2 1 2 5 _ M _ _ _ . 1 2 C _ _	34.5	63
5.9	147.98	181	2.43	6000	1 4 0		
5.1	170.21	207	2.12	6000	1 6 0		
4.4	199.9	245	1.8	6000	2 0 0		
3.4	257.59	316	1.4	6000	2 5 0		
3.1	284.33	346	1.27	6000	2 8 0		
2.7	322.4	396	1.11	6000	3 2 0		
2.5	355.03	435	1.01	6000	3 6 0		
2.1	407.03	499	0.88	6000	4 0 0		
1.9	448.23	550	0.8	6000	4 5 0		

0205

0.18 kW	N2 R/MIN	i	M2 Nm	Fm	N	Unit Designation	Kg	Motor Size
	Output Speed	Ratio	Output Torque	Service Factor	Overhung Load	Column Entry <input type="text" value="1"/> Through <input type="text" value="20"/> Spaces to be filled when entering order	Weight of base mount unit	
	4 POLE							
	165	8.33	10	13.65	4269	K 0 3 3 2 8 . 0 _ M _ _ _ _ . 1 8 A _ _	20.5	63
	122	11.25	13	11.39	4688	1 1 .		
	107	12.8	15	10.5	4882	1 2 .		
	95	14.5	17	9.71	5076	1 4 .		
	74	18.54	22	8.19	5481	1 8 .		
	69	19.98	24	7.77	5606	2 0 .		
	54	25.23	30	6.56	5913	2 5 .		
	48	28.6	34	5.98	5916	2 8 .		
	42	32.68	39	5.46	5917	3 2 .		
	38	36.35	43	5.03	5917	3 6 .		
	34	40.08	48	4.63	5952	4 0 .		
	31	44.11	53	4.21	5957	4 5 .		
	27	51.68	62	3.6	5963	5 0 .		
	22	62	74	3	6000	6 3 .		
	19	72.27	87	2.58	6000	7 1 .		
	17	80.3	96	2.33	6000	8 0 .		
	14	96.7	116	1.6	6000	1 0 0		
	12	110.83	132	1.2	6000	1 1 2		
	11	125.96	151	1.03	6000	1 2 5		
	11	127.79	147	1.52	6000	K 0 3 5 2 1 2 5 _ M _ _ _ _ . 1 8 A _ _	29.5	63
	9.4	145.34	167	1.34	6000	1 4 0		
	8.3	164.66	190	1.18	6000	1 6 0		
	6.5	210.58	243	0.92	6000	2 0 0		
	6	226.95	262	0.86	6000	2 5 0		
	13	105.69	127	3.3	6000	K 0 4 3 2 1 1 2 _ M _ _ _ _ . 1 8 A _ _	26.5	63
	11	120.15	144	3.06	6000	1 2 5		
	10	134.38	156	2.83	6000	K 0 4 5 2 1 2 5 _ M _ _ _ _ . 1 8 A _ _	34.5	63
	9.3	147.98	171	2.57	6000	1 4 0		
	8	170.21	196	2.25	6000	1 6 0		
	6.9	199.9	231	1.9	6000	2 0 0		
	5.3	257.59	299	1.48	6000	2 5 0		
	4.8	284.33	327	1.35	6000	2 8 0		
	4.2	322.4	375	1.18	6000	3 2 0		
	3.9	355.03	412	1.07	6000	3 6 0		
	3.4	407.03	473	0.93	6000	4 0 0		
	3.1	448.23	521	0.85	6000	4 5 0		
	3	452.95	530	1.24	7496	K 0 5 5 2 4 5 0 _ M _ _ _ _ . 1 8 A _ _	48.5	63
	2.7	498.8	584	1.13	7496	5 0 0		
	2.4	573.74	671	0.98	7496	5 6 0		
	2.2	623.76	730	0.9	7496	6 3 0		
	3.1	444.5	522	1.58	8000	K 0 6 5 2 4 5 0 _ M _ _ _ _ . 1 8 A _ _	56.5	63
	2.8	489.49	576	1.43	8000	5 0 0		
	2.4	563.04	662	1.25	8000	5 6 0		
	2.2	612.13	719	1.15	8000	6 3 0		
	1.9	711.95	835	0.99	8000	7 0 0		
	1.7	796.55	931	0.89	8000	8 0 0		
	2.9	465.77	551	3.03	15000	K 0 7 5 2 4 5 0 _ M _ _ _ _ . 1 8 A _ _	74.5	63
	2.7	512.91	607	2.75	15000	5 0 0		
	2.3	589.97	698	2.39	15000	5 6 0		
	2.1	641.41	758	2.2	15000	6 3 0		
	1.9	737.04	870	1.92	15000	7 0 0		
	1.6	835.78	984	1.7	15000	8 0 0		
	1.5	924	1088	1.53	15000	9 0 0		
	1.3	1061.77	1249	1.34	15000	1 0 C		
	1.1	1204.01	1413	1.18	15000	1 1 C		
	1.1	1267.37	1488	1.12	15000	1 2 C		

NOTE
Other output speeds are available using 2 and 8 pole motors - Consult Textron Power Transmission

0205

0.18 kW

6 POLE

N2 R/MIN	i	M2 Nm	Fm	N	Unit Designation	Kg	Motor Size
Output Speed	Ratio	Output Torque	Service Factor	Overhung Load	Column Entry <input type="text" value="1"/> Through <input type="text" value="20"/> Spaces to be filled when entering order	Weight of base mount unit	
108	8.33	15	9.74	4815	K 0 3 3 2 8 . 0 _ M _ _ _ . 1 8 C - -	22.5	71
80	11.25	20	8.18	5271	1 1 .		
70	12.8	23	7.5	5482	1 2 .		
62	14.5	26	6.93	5693	1 4 .		
49	18.54	34	5.83	5915	1 8 .		
45	19.98	36	5.52	5916	2 0 .		
36	25.23	46	4.69	5916	2 5 .		
31	28.6	52	4.26	5914	2 8 .		
28	32.68	60	3.72	5910	3 2 .		
25	36.35	66	3.36	5905	3 6 .		
22	40.08	73	3.04	5965	4 0 .		
20	44.11	81	2.77	5964	4 5 .		
17	51.68	95	2.36	5942	5 0 .		
15	62	113	1.97	5976	6 3 .		
12	72.27	132	1.69	5903	7 1 .		
11	80.3	147	1.53	6000	8 0 .		
9.3	96.7	177	1.05	5923	1 0 0		
7	127.79	226	0.99	6000	K 0 3 5 2 1 2 5 _ M _ _ _ . 1 8 C - -	30.5	71
6.2	145.34	257	0.87	6000	1 4 0		
11	80.1	146	3.01	6000	K 0 4 3 2 8 0 . _ M _ _ _ . 1 8 C - -	27.5	71
10	93.12	170	2.49	6000	1 0 0		
8.5	105.69	193	2.24	5986	1 1 2		
7.5	120.15	219	2.01	6000	1 2 5		
6.7	134.38	239	1.85	6000	K 0 4 5 2 1 2 5 _ M _ _ _ . 1 8 C - -	36.5	71
6.1	147.98	263	1.68	6000	1 4 0		
5.3	170.21	301	1.46	6000	1 6 0		
4.5	199.9	355	1.24	6000	2 0 0		
3.5	257.59	458	0.96	6000	2 5 0		
3.2	284.33	502	0.88	6000	2 8 0		
2	452.95	809	0.81	7496	K 0 5 5 2 4 5 0 _ M _ _ _ . 1 8 C - -	50.5	71
2	444.5	797	1.04	8000	K 0 6 5 2 4 5 0 _ M _ _ _ . 1 8 C - -	58.5	71
1.8	489.49	879	0.94	8000	5 0 0		
1.6	563.04	1010	0.82	8000	5 6 0		
1.9	465.77	839	1.99	15000	K 0 7 5 2 4 5 0 _ M _ _ _ . 1 8 C - -	76.5	71
1.8	512.91	925	1.8	15000	5 0 0		
1.5	589.97	1063	1.57	15000	5 6 0		
1.4	641.41	1155	1.45	15000	6 3 0		
1.2	737.04	1325	1.26	15000	7 0 0		
1.1	835.78	1500	1.11	15000	8 0 0		
0.97	924	1656	1.01	15000	9 0 0		
0.85	1061.77	1901	0.88	15000	1 0 C		

NOTE
Other output speeds are available using 2 and 8 pole motors - Consult Textron Power Transmission

0205

0.25 kW

4 POLE

N2 R/MIN	i	M2 Nm	Fm	N	Unit Designation	Kg	Motor Size
Output Speed	Ratio	Output Torque	Service Factor	Overhung Load	Column Entry 1 Through 20 Spaces to be filled when entering order	Weight of base mount unit	
168	8.33	13	10.04	4233	K 0 3 3 2 8 . 0 _ M _ _ _ . 2 5 A _ _	22.5	71
124	11.25	18	8.38	4640	1 1 .		
109	12.8	21	7.72	4827	1 2 .		
97	14.5	23	7.14	5013	1 4 .		
76	18.54	30	6.02	5401	1 8 .		
70	19.98	33	5.72	5519	2 0 .		
56	25.23	41	4.83	5812	2 5 .		
49	28.6	47	4.4	5818	2 8 .		
43	32.68	53	4.02	5820	3 2 .		
39	36.35	59	3.7	5822	3 6 .		
35	40.08	65	3.41	5896	4 0 .		
32	44.11	72	3.1	5907	4 5 .		
27	51.68	84	2.65	5921	5 0 .		
23	62	101	2.21	6000	6 3 .		
19	72.27	118	1.9	6000	7 1 .		
17	80.3	131	1.71	6000	8 0 .		
14	96.7	158	1.17	6000	1 0 0		
13	110.83	180	0.88	6000	1 1 2		
11	127.79	200	1.12	6000	K 0 3 5 2 1 2 5 _ M _ _ _ . 2 5 A _ _	30.5	71
10	145.34	228	0.98	6000	1 4 0		
8.5	164.66	258	0.87	6000	1 6 0		
20	71.09	116	3.8	6000	K 0 4 3 2 7 1 . _ M _ _ _ . 2 5 A _ _	27.5	71
17	80.1	130	3.38	6000	8 0 .		
15	93.12	152	2.69	6000	1 0 0		
13	105.69	172	2.43	6000	1 1 2		
12	120.15	195	2.25	6000	1 2 5		
10	134.38	212	2.08	6000	K 0 4 5 2 1 2 5 _ M _ _ _ . 2 5 A _ _	36.5	71
9.5	147.98	233	1.89	6000	1 4 0		
8.2	170.21	266	1.65	6000	1 6 0		
7	199.9	315	1.4	6000	2 0 0		
5.4	257.59	406	1.09	6000	2 5 0		
4.9	284.33	444	0.99	6000	2 8 0		
4.3	322.4	509	0.87	6000	3 2 0		
3.1	452.95	720	0.91	7496	K 0 5 5 2 4 5 0 _ M _ _ _ . 2 5 A _ _	50.5	71
2.8	498.8	794	0.83	7496	5 0 0		
3.1	444.5	710	1.16	8000	K 0 6 5 2 4 5 0 _ M _ _ _ . 2 5 A _ _	58.5	71
2.9	489.49	783	1.06	8000	5 0 0		
2.5	563.04	900	0.92	8000	5 6 0		
2.3	612.13	978	0.84	8000	6 3 0		
3	465.77	749	2.23	15000	K 0 7 5 2 4 5 0 _ M _ _ _ . 2 5 A _ _	76.5	71
2.7	512.91	825	2.02	15000	5 0 0		
2.4	589.97	949	1.76	15000	5 6 0		
2.2	641.41	1031	1.62	15000	6 3 0		
1.9	737.04	1183	1.41	15000	7 0 0		
1.7	835.78	1338	1.25	15000	8 0 0		
1.5	924	1479	1.13	15000	9 0 0		
1.3	1061.77	1698	0.98	15000	1 0 C		
1.2	1204.01	1921	0.87	15000	1 1 C		
1.1	1267.37	2023	0.83	15000	1 2 C		

NOTE
Other output speeds are available using 2 and 8 pole motors - Consult Textron Power Transmission

0205

0.25 kW	N2 R/MIN	i	M2 Nm	Fm	N	Unit Designation	Kg	Motor Size
	Output Speed	Ratio	Output Torque	Service Factor	Overhung Load	Column Entry 1 Through 20 Spaces to be filled when entering order	Weight of base mount unit	
	6 POLE							
	108	8.33	21	7.01	4764	K 0 3 3 2 8 . 0 _ M _ _ _ . 2 5 C _ _	22.5	71
	80	11.25	28	5.89	5202	1 1 .		
	70	12.8	32	5.4	5404	1 2 .		
	62	14.5	37	4.99	5604	1 4 .		
	49	18.54	47	4.2	5816	1 8 .		
	45	19.98	51	3.97	5819	2 0 .		
	36	25.23	64	3.38	5819	2 5 .		
	31	28.6	73	3.06	5815	2 8 .		
	28	32.68	83	2.68	5805	3 2 .		
	25	36.35	93	2.42	5794	3 6 .		
	22	40.08	102	2.19	5925	4 0 .		
	20	44.11	112	1.99	5923	4 5 .		
	17	51.68	132	1.7	5876	5 0 .		
	15	62	158	1.42	5948	6 3 .		
	12	72.27	184	1.22	5791	7 1 .		
	11	80.3	204	1.1	6000	8 0 .		
	18	49.35	125	3.5	6000	K 0 4 3 2 5 0 _ M _ _ _ . 2 5 C _ _	27.5	71
	15	59.24	150	2.92	6000	6 3 .		
	13	71.09	180	2.44	6000	7 1 .		
	11	80.1	203	2.17	6000	8 0 .		
	10	93.12	237	1.79	6000	1 0 0		
	8.5	105.69	268	1.62	5971	1 1 2		
	7.5	120.15	304	1.45	6000	1 2 5		
	6.7	134.38	332	1.33	6000	K 0 4 5 2 1 2 5 _ M _ _ _ . 2 5 C _ _	36.5	71
	6.1	147.98	365	1.21	6000	1 4 0		
	5.3	170.21	418	1.05	6000	1 6 0		
	4.5	199.9	493	0.89	6000	2 0 0		
	1.9	465.77	1166	1.43	15000	K 0 7 5 2 4 5 0 _ M _ _ _ . 2 5 C _ _	76.5	71
	1.8	512.91	1285	1.3	15000	5 0 0		
	1.5	589.97	1476	1.13	15000	5 6 0		
	1.4	641.41	1604	1.04	15000	6 3 0		
	1.2	737.04	1841	0.91	15000	7 0 0		
	1.1	835.78	2083	0.8	15000	8 0 0		

NOTE
Other output speeds are available using 2 and 8 pole motors - Consult Textron Power Transmission

0205

0.37 kW	N2 R/MIN	i	M2 Nm	Fm	N	Unit Designation	Kg	
	Output Speed	Ratio	Output Torque	Service Factor	Overhung Load	Column Entry 1 Through 20 Spaces to be filled when entering order	Weight of base mount unit	Motor Size
	4 POLE							
	168	8.33	20	6.78	4171	K 0 3 3 2 8 . 0 _ M _ _ _ . 3 7 A _ _	22.5	71
	124	11.25	27	5.66	4556	1 1 .		
	109	12.8	31	5.22	4732	1 2 .		
	97	14.5	35	4.83	4906	1 4 .		
	76	18.54	45	4.07	5263	1 8 .		
	70	19.98	48	3.86	5372	2 0 .		
	56	25.23	61	3.26	5640	2 5 .		
	49	28.6	69	2.97	5650	2 8 .		
	43	32.68	79	2.71	5655	3 2 .		
	39	36.35	88	2.5	5658	3 6 .		
	35	40.08	97	2.3	5801	4 0 .		
	32	44.11	107	2.09	5821	4 5 .		
	27	51.68	125	1.79	5849	5 0 .		
	23	62	150	1.49	6000	6 3 .		
	19	72.27	175	1.28	6000	7 1 .		
	17	80.3	194	1.16	6000	8 0 .		
	31	45.39	110	3.94	6000	K 0 4 3 2 4 5 . _ M _ _ _ . 3 7 A _ _	27.5	71
	28	49.35	119	3.68	6000	5 0 .		
	24	59.24	143	3.08	6000	6 3 .		
	20	71.09	171	2.57	6000	7 1 .		
	17	80.1	193	2.28	6000	8 0 .		
	15	93.12	225	1.82	6000	1 0 0		
	13	105.69	255	1.64	6000	1 1 2		
	12	120.15	289	1.52	6000	1 2 5		
	10	134.38	313	1.41	6000	K 0 4 5 2 1 2 5 _ M _ _ _ . 3 7 A _ _	36.5	71
	9.5	147.98	345	1.28	6000	1 4 0		
	8.2	170.21	394	1.12	6000	1 6 0		
	7	199.9	466	0.95	6000	2 0 0		
	3	465.77	1108	1.51	15000	K 0 7 5 2 4 5 0 _ M _ _ _ . 3 7 A _ _	76.5	71
	2.7	512.91	1222	1.37	15000	5 0 0		
	2.4	589.97	1404	1.19	15000	5 6 0		
	2.2	641.41	1526	1.09	15000	6 3 0		
	1.9	737.04	1751	0.95	15000	7 0 0		
	1.7	835.78	1980	0.84	15000	8 0 0		

NOTE
Other output speeds are available using 2 and 8 pole motors - Consult Textron Power Transmission

0205

0.37 kW	N2	i	M2	Fm	N	Unit Designation	Kg	Motor Size		
	R/MIN		Nm			Column Entry 1 Through 20	Weight of base mount unit			
	Output Speed	Ratio	Output Torque	Service Factor	Overhung Load	Spaces to be filled when entering order				
6 POLE	110	8.33	30	4.84	4676	K 0 3 3 2 8 . 0 _ M _ _ _ . 3 7 C - -	25.5	80A		
	82	11.25	41	4.07	5085	1 1 .				
	72	12.8	47	3.73	5269	1 2 .				
	63	14.5	53	3.44	5451	1 4 .				
	50	18.54	68	2.9	5647	1 8 .				
	46	19.98	74	2.75	5653	2 0 .				
	36	25.23	93	2.33	5653	2 5 .				
	32	28.6	106	2.12	5645	2 8 .				
	28	32.68	121	1.85	5625	3 2 .				
	25	36.35	134	1.67	5604	3 6 .				
	23	40.08	148	1.51	5857	4 0 .				
	21	44.11	163	1.38	5853	4 5 .				
	18	51.68	191	1.18	5761	5 0 .				
	15	62	229	0.98	5901	6 3 .				
	13	72.27	267	0.84	5598	7 1 .				
	29	31.54	116	3.7	6000	K 0 4 3 2 3 2 . _ M _ _ _ . 3 7 C - -	31.5	80A		
	26	35.83	131	3.34	6000	3 6 .				
	23	39.46	145	3.03	6000	4 0 .				
	20	45.39	168	2.62	6000	4 5 .				
	19	49.35	182	2.42	6000	5 0 .				
	16	59.24	218	2.02	6000	6 3 .				
	13	71.09	261	1.69	5990	7 1 .				
	11	80.1	294	1.5	6000	8 0 .				
	10	93.12	343	1.24	6000	1 0 0				
	8.7	105.69	388	1.12	5944	1 1 2				
	7.7	120.15	441	1	6000	1 2 5				
	6.8	134.38	480	0.92	6000	K 0 4 5 2 1 2 5 _ M _ _ _ . 3 7 C - -			39.5	80A
	6.2	147.98	529	0.83	6000	1 4 0				
	12	79.77	294	2.24	8000	K 0 5 3 2 8 0 . _ M _ _ _ . 3 7 C - -			40.5	80A
	9.4	97.76	360	1.83	8000	1 0 0				
	8.4	108.96	401	1.64	8000	1 1 2				
	7.5	122.2	448	1.35	8000	1 2 5				
	13	71.49	263	3.13	8000	K 0 6 3 2 7 1 . _ M _ _ _ . 3 7 C - -	48.5	80A		
	12	78.28	290	2.85	8000	8 0 .				
	10	95.93	353	2.34	8000	1 0 0				
	8.6	106.93	393	2.1	8000	1 1 2				
	7.7	119.92	439	1.35	8000	1 2 5				
	2	465.77	1688	0.99	15000	K 0 7 5 2 4 5 0 _ M _ _ _ . 3 7 C - -	79.5	80A		
	1.8	512.91	1861	0.9	15000	5 0 0				
	2	462.28	1672	1.62	15674	K 0 8 5 2 4 5 0 _ M _ _ _ . 3 7 C - -	148.5	80A		
	1.8	505.9	1829	1.48	15674	5 0 0				
	1.7	537.67	1944	1.39	15674	5 6 0				
	1.4	641.16	2317	1.17	15674	6 3 0				
	1.2	759.86	2743	0.99	15674	7 0 0				
	1.1	811.29	2927	0.93	15674	8 0 0				
1	887.84	3203	0.85	15674	9 0 0					
1.6	562.75	2039	1.85	34000	K 0 9 5 1 5 6 0 _ M _ _ _ . 3 7 C - -	206.5	80A			
1.4	654.52	2370	1.59	34000	6 3 0					
1.3	727.17	2630	1.44	34000	7 0 0					
1.2	788.65	2853	1.48	34000	8 0 0					
0.98	940.44	3400	1.24	34000	9 0 0					
0.9	1027.68	3710	1.02	34000	1 0 C					
0.83	1114.56	4025	1.05	34000	1 1 C					
0.77	1190	4295	0.98	34000	1 2 C					

NOTE
Other output speeds are available using 2 and 8 pole motors - Consult Textron Power Transmission

0205

0.55 kW	N2 R/MIN	i	M2 Nm	Fm	N	Unit Designation	Kg	Motor Size
	Output Speed	Ratio	Output Torque	Service Factor	Overhung Load	Column Entry <input type="text" value="1"/> Through <input type="text" value="20"/> Spaces to be filled when entering order	Weight of base mount unit	
	4 POLE							
171	8.33	29	4.63	4078	K 0 3 3 2 8 . 0 _ M _ _ _ . 5 5 A _ _	25.5	80A	
126	11.25	40	3.86	4432	1 1 .			
111	12.8	45	3.56	4590	1 2 .			
98	14.5	51	3.29	4745	1 4 .			
77	18.54	66	2.78	5057	1 8 .			
71	19.98	71	2.64	5150	2 0 .			
56	25.23	90	2.23	5381	2 5 .			
50	28.6	102	2.03	5398	2 8 .			
43	32.68	116	1.85	5407	3 2 .			
39	36.35	129	1.71	5412	3 6 .			
35	40.08	143	1.57	5658	4 0 .			
32	44.11	157	1.43	5692	4 5 .			
27	51.68	184	1.22	5740	5 0 .			
23	62	220	1.02	6000	6 3 .			
20	72.27	256	0.88	6000	7 1 .			
51	27.76	99	3.85	6000	K 0 4 3 2 2 8 . _ M _ _ _ . 5 5 A _ _	31.5	80A	
45	31.54	112	3.51	6000	3 2 .			
40	35.83	127	3.28	6000	3 6 .			
36	39.46	140	2.97	6000	4 0 .			
31	45.39	162	2.69	6000	4 5 .			
29	49.35	175	2.51	6000	5 0 .			
24	59.24	209	2.1	6000	6 3 .			
20	71.09	251	1.75	6000	7 1 .			
18	80.1	283	1.56	6000	8 0 .			
15	93.12	330	1.24	6000	1 0 0			
13	105.69	374	1.12	6000	1 1 2			
12	120.15	424	1.04	6000	1 2 5			
11	134.38	460	0.96	6000	K 0 4 5 2 1 2 5 _ M _ _ _ . 5 5 A _ _	39.5	80A	
10	147.98	505	0.87	6000	1 4 0			
19	72.85	258	2.55	8000	K 0 5 3 2 7 1 . _ M _ _ _ . 5 5 A _ _	40.5	80A	
18	79.77	282	2.33	8000	8 0 .			
15	97.76	345	1.91	8000	1 0 0			
13	108.96	386	1.71	8000	1 1 2			
12	122.2	432	1.41	8000	1 2 5			
12	118.4	406	1.62	7496	K 0 5 5 2 1 2 5 _ M _ _ _ . 5 5 A _ _	53.5	80A	
10	142.79	492	1.34	7496	1 4 0			
9	157.35	542	1.21	7496	1 6 0			
6.8	207.81	713	0.92	7496	2 0 0			
23	60.62	216	3.83	8000	K 0 6 3 2 6 3 . _ M _ _ _ . 5 5 A _ _	48.5	80A	
20	71.49	253	3.26	8000	7 1 .			
18	78.28	278	2.97	8000	8 0 .			
15	95.93	341	2.42	8000	1 0 0			
13	106.93	377	2.19	8000	1 1 2			
12	119.92	423	1.41	8000	1 2 5			
12	116.19	401	2.06	8000	K 0 6 5 2 1 2 5 _ M _ _ _ . 5 5 A _ _	61.5	80A	
10	140.12	485	1.7	8000	1 4 0			
9.2	154.41	535	1.54	8000	1 6 0			
7	203.93	704	1.17	8000	2 0 0			
5.5	259.02	895	0.92	8000	2 5 0			
4.8	294.26	1017	0.81	8000	2 8 0			
13	113.5	401	3.99	15000	K 0 7 3 2 1 1 2 _ M _ _ _ . 5 5 A _ _	67.5	80A	
11	126.11	442	3.12	15000	1 2 5			
12	120.29	420	3.98	15000	K 0 7 5 2 1 2 5 _ M _ _ _ . 5 5 A _ _	79.5	80A	
11	133.48	467	3.57	15000	1 4 0			
10	147.09	515	3.24	15000	1 6 0			
6.7	211.12	737	2.27	15000	2 0 0			
6.1	233.36	816	2.05	15000	2 5 0			
5.4	265.1	927	1.8	15000	2 8 0			
4.7	304.63	1063	1.57	15000	3 2 0			
3.8	373.86	1305	1.28	15000	3 6 0			
3.4	414.65	1447	1.15	15000	4 0 0			
3	465.77	1625	1.03	15000	4 5 0			
2.8	512.91	1791	0.93	15000	5 0 0			
2.4	589.97	2058	0.81	15000	5 6 0			
3.1	462.28	1605	1.69	15674	K 0 8 5 2 4 5 0 _ M _ _ _ . 5 5 A _ _	148.5	80A	
2.8	505.9	1756	1.54	15674	5 0 0			
2.6	537.67	1867	1.45	15674	5 6 0			
2.2	641.16	2226	1.22	15674	6 3 0			
1.9	759.86	2637	1.03	15674	7 0 0			
1.8	811.29	2815	0.96	15674	8 0 0			
1.6	887.84	3079	0.88	15674	9 0 0			
2.5	562.75	1959	1.93	34000	K 0 9 5 1 5 6 0 _ M _ _ _ . 5 5 A _ _	206.5	80A	
2.2	654.52	2278	1.66	34000	6 3 0			
2	727.17	2526	1.49	34000	7 0 0			
1.8	788.65	2742	1.54	34000	8 0 0			
1.5	940.44	3269	1.29	34000	9 0 0			
1.4	1027.68	3567	1.06	34000	1 0 C			
1.3	1114.56	3871	1.09	34000	1 1 C			
1.2	1190	4132	1.02	34000	1 2 C			
0.96	1476.68	5121	0.82	34000	1 4 C			

NOTE
Other output speeds are available using 2 and 8 pole motors - Consult Textron Power Transmission

0205

0.55 kW	N2 R/MIN	i	M2 Nm	Fm	N	Unit Designation	Kg	Motor Size
	Output Speed	Ratio	Output Torque	Service Factor	Overhung Load	Column Entry <input type="text" value="1"/> Through <input type="text" value="20"/> Spaces to be filled when entering order	Weight of base mount unit	
	6 POLE							
	110	8.33	46	3.26	4544	K 0 3 3 2 8 . 0 _ M _ _ _ . 5 5 C _ _	27	80B
	82	11.25	62	2.74	4908	1 1 .		
	72	12.8	70	2.51	5067	1 2 .		
	63	14.5	79	2.32	5221	1 4 .		
	50	18.54	102	1.95	5394	1 8 .		
	46	19.98	110	1.85	5403	2 0 .		
	36	25.23	139	1.57	5403	2 5 .		
	32	28.6	158	1.42	5390	2 8 .		
	28	32.68	180	1.25	5355	3 2 .		
	25	36.35	200	1.12	5319	3 6 .		
	23	40.08	221	1.02	5754	4 0 .		
	21	44.11	243	0.93	5747	4 5 .		
	51	17.95	99	3.64	6000	K 0 4 3 2 1 8 . _ M _ _ _ . 5 5 C _ _	33	80B
	45	20.4	112	3.35	6000	2 0 .		
	37	25.03	137	2.91	6000	2 5 .		
	33	27.76	153	2.68	6000	2 8 .		
	29	31.54	173	2.49	6000	3 2 .		
	26	35.83	196	2.25	6000	3 6 .		
	23	39.46	216	2.04	6000	4 0 .		
	20	45.39	250	1.76	6000	4 5 .		
	19	49.35	270	1.63	6000	5 0 .		
	16	59.24	324	1.36	6000	6 3 .		
	13	71.09	388	1.13	5975	7 1 .		
	11	80.1	437	1.01	6000	8 0 .		
	10	93.12	510	0.83	6000	1 0 0		
	15	61.78	340	1.93	8000	K 0 5 3 2 6 3 . _ M _ _ _ . 5 5 C _ _	42	80B
	13	72.85	400	1.65	8000	7 1 .		
	12	79.77	437	1.51	7321	8 0 .		
	9.4	97.76	535	1.23	7176	1 0 0		
	8.4	108.96	596	1.1	6954	1 1 2		
	7.5	122.2	667	0.91	6976	1 2 5		
	7.8	118.4	631	1.04	7496	K 0 5 5 2 1 2 5 _ M _ _ _ . 5 5 C _ _	55	80B
	6.4	142.79	764	0.86	7496	1 4 0		
	20	45.76	252	3.28	8000	K 0 6 3 2 4 5 . _ M _ _ _ . 5 5 C _ _	50	80B
	19	48.86	269	3.07	8000	5 0 .		
	15	60.62	334	2.47	8000	6 3 .		
	13	71.49	392	2.11	7928	7 1 .		
	12	78.28	431	1.92	8000	8 0 .		
	10	95.93	525	1.57	8000	1 0 0		
	8.6	106.93	585	1.41	7858	1 1 2		
	7.7	119.92	654	0.91	8000	1 2 5		
	7.9	116.19	623	1.33	8000	K 0 6 5 2 1 2 5 _ M _ _ _ . 5 5 C _ _	63	80B
	6.6	140.12	753	1.1	8000	1 4 0		
	6	154.41	830	1	8000	1 6 0		
	9.3	98.65	536	2.98	15000	K 0 7 3 2 1 0 0 _ M _ _ _ . 5 5 C _ _	69	80B
	8.1	113.5	620	2.58	15000	1 1 2		
	7.3	126.11	682	2.02	15000	1 2 5		
	7.6	120.29	650	2.57	15000	K 0 7 5 2 1 2 5 _ M _ _ _ . 5 5 C _ _	81	80B
	6.9	133.48	723	2.31	15000	1 4 0		
	6.3	147.09	797	2.09	15000	1 6 0		
	4.4	211.12	1141	1.46	15000	2 0 0		
	3.9	233.36	1262	1.32	15000	2 5 0		
	3.5	265.1	1434	1.16	15000	2 8 0		
	3	304.63	1645	1.02	15000	3 2 0		
	2.5	373.86	2018	0.83	15000	3 6 0		
	2	462.28	2486	1.09	15674	K 0 8 5 2 4 5 0 _ M _ _ _ . 5 5 C _ _	150	80B
	1.8	505.9	2719	1	15674	5 0 0		
	1.7	537.67	2890	0.94	15674	5 6 0		
	1.6	562.75	3031	1.25	34000	K 0 9 5 1 5 6 0 _ M _ _ _ . 5 5 C _ _	208	80B
	1.4	654.52	3524	1.07	34000	6 3 0		
	1.3	727.17	3909	0.97	34000	7 0 0		
	1.2	788.65	4242	0.99	34000	8 0 0		
	0.98	940.44	5054	0.83	34000	9 0 0		
	1.8	514.73	2775	2.59	43100	K 1 0 5 1 5 0 0 _ M _ _ _ . 5 5 C _ _	332	80B
	1.6	566.2	3051	2.35	43100	5 6 0		
	1.4	650.62	3505	2.05	43100	6 3 0		
	1.3	722.98	3888	1.85	43100	7 0 0		
	1.2	783.15	4209	1.71	43100	8 0 0		
	1	904.27	4859	1.48	43100	9 0 0		
	0.94	979.53	5259	1.37	43100	1 0 C		
	0.79	1170.88	6283	1.14	43100	1 1 C		
	0.73	1268.32	6799	1.06	43100	1 2 C		
	0.63	1470.48	7872	0.91	43100	1 4 C		
	0.56	1634.03	8737	0.82	43100	1 6 C		
	1.6	584.22	3150	3.84	61368	K 1 2 5 1 5 6 0 _ M _ _ _ . 5 5 C _ _	492	80B
	1.4	671.32	3618	3.34	61368	6 3 0		
	1.2	756.72	4076	2.97	61368	7 0 0		
	1.1	808.78	4353	2.85	61293	8 0 0		
	0.97	946.46	5093	2.37	61368	9 0 0		
	0.91	1011.58	5439	2.28	61293	1 0 C		
	0.81	1140.25	6128	2.03	61293	1 1 C		
	0.75	1225.51	6584	1.84	61368	1 2 C		
	0.61	1518.59	8141	1.53	61293	1 4 C		
	0.54	1711.76	9174	1.35	61293	1 6 C		
	0.51	1811.28	9693	1.28	61293	1 8 C		
	0.45	2041.68	10923	1.14	61293	2 0 C		
	0.41	2235.86	11949	1.04	61293	2 2 C		
	0.34	2683.03	14299	0.87	61293	2 5 C		
	0.32	2887.22	15351	0.81	61293	2 8 C		

NOTE
Other output speeds are available using 2 and 8 pole motors - Consult Textron Power Transmission

0205

0.75 kW	N2 R/MIN	i	M2 Nm	Fm	N	Unit Designation	Kg	Motor Size
	Output Speed	Ratio	Output Torque	Service Factor	Overhung Load	Column Entry 1 Through 20 Spaces to be filled when entering order	Weight of base mount unit	
	4 POLE							
	170	8.33	40	3.38	3975	K 0 3 3 2 8 . 0 _ M _ _ _ . 7 5 A _ _	25.5	80A
	126	11.25	54	2.82	4293	1 1 .		
	111	12.8	62	2.6	4433	1 2 .		
	98	14.5	71	2.41	4566	1 4 .		
	76	18.54	90	2.03	4828	1 8 .		
	71	19.98	98	1.93	4903	2 0 .		
	56	25.23	123	1.63	5093	2 5 .		
	49	28.6	140	1.48	5119	2 8 .		
	43	32.68	158	1.35	5132	3 2 .		
	39	36.35	177	1.25	5138	3 6 .		
	35	40.08	195	1.15	5500	4 0 .		
	32	44.11	215	1.04	5550	4 5 .		
	27	51.68	252	0.89	5620	5 0 .		
	79	17.95	87	3.81	6000	K 0 4 3 2 1 8 . _ M _ _ _ . 7 5 A _ _	31.5	80A
	69	20.4	99	3.49	6000	2 0 .		
	57	25.03	122	3.03	5945	2 5 .		
	51	27.76	135	2.81	5944	2 8 .		
	45	31.54	153	2.56	5939	3 2 .		
	39	35.83	175	2.39	6000	3 6 .		
	36	39.46	192	2.17	6000	4 0 .		
	31	45.39	221	1.96	6000	4 5 .		
	29	49.35	240	1.83	6000	5 0 .		
	24	59.24	287	1.54	6000	6 3 .		
	20	71.09	344	1.28	6000	7 1 .		
	18	80.1	387	1.14	6000	8 0 .		
	15	93.12	452	0.91	6000	1 0 0		
	13	105.69	512	0.82	6000	1 1 2		
	43	32.99	160	3.77	7830	K 0 5 3 2 3 2 . _ M _ _ _ . 7 5 A _ _	40.5	80A
	38	36.91	180	3.54	8000	3 6 .		
	36	39.34	192	3.29	8000	4 0 .		
	30	46.63	227	2.89	8000	4 5 .		
	28	49.78	243	2.71	8000	5 0 .		
	23	61.78	301	2.19	8000	6 3 .		
	19	72.85	354	1.86	7667	7 1 .		
	18	79.77	386	1.7	7637	8 0 .		
	14	97.76	473	1.39	7760	1 0 0		
	13	108.96	528	1.25	7541	1 1 2		
	12	122.2	591	1.03	8000	1 2 5		
	12	118.4	555	1.19	7496	K 0 5 5 2 1 2 5 _ M _ _ _ . 7 5 A _ _	53.5	80A
	10	142.79	673	0.98	7496	1 4 0		
	9	157.35	742	0.89	7496	1 6 0		
	31	45.76	223	3.71	8000	K 0 6 3 2 4 5 . _ M _ _ _ . 7 5 A _ _	48.5	80A
	29	48.86	238	3.47	8000	5 0 .		
	23	60.62	295	2.8	8000	6 3 .		
	20	71.49	347	2.38	8000	7 1 .		
	18	78.28	380	2.17	8000	8 0 .		
	15	95.93	467	1.77	8000	1 0 0		
	13	106.93	516	1.6	8000	1 1 2		
	12	119.92	579	1.03	8000	1 2 5		
	12	116.19	549	1.51	8000	K 0 6 5 2 1 2 5 _ M _ _ _ . 7 5 A _ _	61.5	80A
	10	140.12	665	1.24	8000	1 4 0		
	9.2	154.41	732	1.13	8000	1 6 0		
	6.9	203.93	964	0.86	8000	2 0 0		
	14	98.65	476	3.36	15000	K 0 7 3 2 1 0 0 _ M _ _ _ . 7 5 A _ _	67.5	80A
	12	113.5	548	2.91	15000	1 1 2		
	11	126.11	606	2.28	15000	1 2 5		
	12	120.29	574	2.91	15000	K 0 7 5 2 1 2 5 _ M _ _ _ . 7 5 A _ _	79.5	80A
	11	133.48	640	2.61	15000	1 4 0		
	10	147.09	705	2.37	15000	1 6 0		
	6.7	211.12	1009	1.66	15000	2 0 0		
	6.1	233.36	1117	1.49	15000	2 5 0		
	5.3	265.1	1269	1.32	15000	2 8 0		
	4.6	304.63	1455	1.15	15000	3 2 0		
	3.8	373.86	1786	0.94	15000	3 6 0		
	3.4	414.65	1980	0.84	15000	4 0 0		
	3.1	462.28	2197	1.23	15674	K 0 8 5 2 4 5 0 _ M _ _ _ . 7 5 A _ _	148.5	80A
	2.8	505.9	2403	1.13	15674	5 0 0		
	2.6	537.67	2555	1.06	15674	5 6 0		
	2.2	641.16	3047	0.89	15674	6 3 0		
	2.5	562.75	2681	1.41	34000	K 0 9 5 1 5 6 0 _ M _ _ _ . 7 5 A _ _	206.5	80A
	2.2	654.52	3118	1.21	34000	6 3 0		
	1.9	727.17	3457	1.09	34000	7 0 0		
	1.8	788.65	3752	1.12	34000	8 0 0		
	1.5	940.44	4473	0.94	34000	9 0 0		

NOTE
Other output speeds are available using 2 and 8 pole motors - Consult Textron Power Transmission

0205

0.75 kW	N2 R/MIN	i	M2 Nm	Fm	N	Unit Designation	Kg				
	Output Speed	Ratio	Output Torque	Service Factor	Overhung Load	Column Entry <input type="text" value="1"/> Through <input type="text" value="20"/> Spaces to be filled when entering order	Weight of base mount unit	Motor Size			
4 POLE	2.7	514.73	2453	2.93	43100	K 1 0 5 1 5 0 0 _ M _ _ _ . 7 5 A _ _	330.5	80A			
	2.5	566.2	2698	2.66	43100				5 6 0		
	2.2	650.62	3100	2.32	43100				6 3 0		
	2	722.98	3438	2.09	43100				7 0 0		
	1.8	783.15	3721	1.93	43100				8 0 0		
	1.6	904.27	4299	1.67	43100				9 0 0		
	1.4	979.53	4653	1.54	43100				1 0 C		
	1.2	1170.88	5562	1.29	43100				1 1 C		
	1.1	1268.32	6019	1.19	43100				1 2 C		
	0.96	1470.48	6973	1.03	43100				1 4 C		
	0.87	1634.03	7736	0.93	43100				1 6 C		
	0.81	1753.89	8307	0.86	43100				1 8 C		
	2.1	671.32	3203	3.77	61368				K 1 2 5 1 6 3 0 _ M _ _ _ . 7 5 A _ _	490.5	80A
	1.9	756.72	3608	3.35	61368						
	1.7	808.78	3854	3.22	61293	8 0 0					
	1.5	946.46	4510	2.68	61368	9 0 0					
	1.4	1011.58	4817	2.58	61293	1 0 C					
	1.2	1140.25	5425	2.29	61293	1 1 C					
	1.2	1225.51	5833	2.07	61368	1 2 C					
	0.93	1518.59	7215	1.72	61293	1 4 C					
	0.83	1711.76	8128	1.53	61293	1 6 C					
	0.78	1811.28	8594	1.45	61293	1 8 C					
	0.69	2041.68	9683	1.28	61293	2 0 C					
	0.63	2235.86	10595	1.17	61293	2 2 C					
	0.53	2683.03	12685	0.98	61293	2 5 C					
	0.49	2887.22	13594	0.91	61293	2 8 C					

NOTE
Other output speeds are available using 2 and 8 pole motors - Consult Textron Power Transmission

0205

0.75 kW	N2 R/MIN	i	M2 Nm	Fm	N	Unit Designation	Kg	Motor Size
	Output Speed	Ratio	Output Torque	Service Factor	Overhung Load	Column Entry <input type="text" value="1"/> Through <input type="text" value="20"/> Spaces to be filled when entering order	Weight of base mount unit	
	6 POLE							
	110	8.33	62	2.39	4397	K 0 3 3 2 8 . 0 _ M _ _ _ . 7 5 C - -	30.5	90S
	82	11.25	84	2.01	4712	1 1 .		
	72	12.8	96	1.84	4842	1 2 .		
	63	14.5	108	1.7	4966	1 4 .		
	50	18.54	139	1.43	5112	1 8 .		
	46	19.98	150	1.35	5125	2 0 .		
	36	25.23	189	1.15	5125	2 5 .		
	32	28.6	215	1.04	5106	2 8 .		
	28	32.68	246	0.91	5055	3 2 .		
	25	36.35	273	0.82	5003	3 6 .		
	81	11.3	85	3.63	6000	K 0 4 3 2 1 1 . _ M _ _ _ . 7 5 C - -	35.5	90S
	74	12.45	93	3.42	6000	1 2 .		
	65	14.14	106	3.14	6000	1 4 .		
	51	17.95	135	2.67	6000	1 8 .		
	45	20.4	153	2.45	6000	2 0 .		
	37	25.03	187	2.13	6000	2 5 .		
	33	27.76	209	1.97	6000	2 8 .		
	29	31.54	236	1.83	6000	3 2 .		
	26	35.83	267	1.65	6000	3 6 .		
	23	39.46	294	1.49	6000	4 0 .		
	20	45.39	341	1.29	6000	4 5 .		
	19	49.35	369	1.19	6000	5 0 .		
	16	59.24	443	1	6000	6 3 .		
	13	71.09	530	0.83	5958	7 1 .		
	32	28.37	213	2.96	8000	K 0 5 3 2 2 8 . _ M _ _ _ . 7 5 C - -	45.5	90S
	28	32.99	247	2.66	8000	3 2 .		
	25	36.91	277	2.38	8000	3 6 .		
	23	39.34	296	2.22	8000	4 0 .		
	20	46.63	350	1.88	8000	4 5 .		
	18	49.78	373	1.76	8000	5 0 .		
	15	61.78	464	1.42	7520	6 3 .		
	13	72.85	545	1.21	7265	7 1 .		
	12	79.77	596	1.1	6567	8 0 .		
	9.4	97.76	730	0.9	6261	1 0 0		
	8.4	108.96	813	0.81	5792	1 1 2		
	33	27.84	209	3.95	8000	K 0 6 3 2 2 8 . _ M _ _ _ . 7 5 C - -	53.5	90S
	28	32.38	243	3.4	8000	3 2 .		
	25	36.22	271	3.04	8000	3 6 .		
	24	38.61	290	2.85	8000	4 0 .		
	20	45.76	344	2.4	8000	4 5 .		
	19	48.86	367	2.25	8000	5 0 .		
	15	60.62	455	1.81	8000	6 3 .		
	13	71.49	534	1.55	7848	7 1 .		
	12	78.28	588	1.41	8000	8 0 .		
	10	95.93	716	1.15	8000	1 0 0		
	8.6	106.93	798	1.04	7700	1 1 2		
	7.9	116.19	849	0.97	8000	K 0 6 5 2 1 2 5 _ M _ _ _ . 7 5 C - -	66.5	90S
	6.6	140.12	1027	0.8	8000	1 4 0		
	12	75.07	559	2.86	15000	K 0 7 3 2 7 1 . _ M _ _ _ . 7 5 C - -	72.5	90S
	11	82.21	613	2.61	15000	8 0 .		
	9.3	98.65	732	2.18	14487	1 0 0		
	8.1	113.5	846	1.89	14539	1 1 2		
	7.3	126.11	931	1.48	14894	1 2 5		
	7.6	120.29	886	1.88	15000	K 0 7 5 2 1 2 5 _ M _ _ _ . 7 5 C - -	84.5	90S
	6.9	133.48	986	1.69	15000	1 4 0		
	6.3	147.09	1087	1.54	15000	1 6 0		
	4.4	211.12	1556	1.07	15000	2 0 0		
	3.9	233.36	1722	0.97	15000	2 5 0		
	3.5	265.1	1955	0.85	15000	2 8 0		
	8.6	107.1	797	3.36	21500	K 0 8 3 2 1 1 2 _ M _ _ _ . 7 5 C - -	127.5	90S
	7.5	123.33	915	2.93	21500	1 2 5		
	1.6	562.75	4134	0.91	34000	K 0 9 5 1 5 6 0 _ M _ _ _ . 7 5 C - -	211.5	90S
	1.8	514.73	3784	1.9	43100	K 1 0 5 1 5 0 0 _ M _ _ _ . 7 5 C - -	335.5	90S
	1.6	566.2	4161	1.73	43100	5 6 0		
	1.4	650.62	4779	1.5	43100	6 3 0		
	1.3	722.98	5303	1.36	43100	7 0 0		
	1.2	783.15	5739	1.25	43100	8 0 0		
	1	904.27	6627	1.08	43100	9 0 0		
	0.94	979.53	7172	1	43100	1 0 C		
	0.79	1170.88	8568	0.84	43100	1 1 C		
	1.7	531.11	3907	3.1	61368	K 1 2 5 1 5 0 0 _ M _ _ _ . 7 5 C - -	495.5	90S
	1.6	584.22	4296	2.81	61368	5 6 0		
	1.4	671.32	4934	2.45	61368	6 3 0		
	1.2	756.72	5559	2.18	61368	7 0 0		
	1.1	808.78	5937	2.09	61293	8 0 0		
	0.97	946.46	6946	1.74	61368	9 0 0		
	0.91	1011.58	7417	1.68	61293	1 0 C		
	0.81	1140.25	8357	1.49	61293	1 1 C		
	0.75	1225.51	8979	1.35	61368	1 2 C		
	0.61	1518.59	11101	1.12	61293	1 4 C		
	0.54	1711.76	12510	0.99	61293	1 6 C		
	0.51	1811.28	13217	0.94	61293	1 8 C		
	0.45	2041.68	14895	0.83	61293	2 0 C		

NOTE
Other output speeds are available using 2 and 8 pole motors - Consult Textron Power Transmission

0205

1.1 kW	N2	i	M2	Fm	N	Unit Designation	Kg	Motor Size		
	R/MIN		Nm			Column Entry 1 Through 20	Weight of base mount unit			
	Output Speed	Ratio	Output Torque	Service Factor	Overhung Load	Spaces to be filled when entering order				
4 POLE	169	8.33	59	2.3	3795	K 0 3 3 2 8 . 0 _ M _ _ _ _ 1 . 1 A - -	30.5	90S		
	125	11.25	80	1.92	4051	1 1 .				
	110	12.8	92	1.77	4157	1 2 .				
	97	14.5	104	1.64	4253	1 4 .				
	76	18.54	133	1.38	4427	1 8 .				
	71	19.98	144	1.31	4472	2 0 .				
	56	25.23	181	1.11	4590	2 5 .				
	49	28.6	206	1.01	4630	2 8 .				
	43	32.68	233	0.92	4650	3 2 .				
	39	36.35	260	0.85	4660	3 6 .				
	125	11.3	81	3.5	5740	K 0 4 3 2 1 1 . _ M _ _ _ _ 1 . 1 A - -			35.5	90S
	113	12.45	89	3.3	5890	1 2 .				
	100	14.14	101	3.04	6000	1 4 .				
	79	17.95	128	2.59	5867	1 8 .				
	69	20.4	146	2.37	5881	2 0 .				
	56	25.03	179	2.06	5850	2 5 .				
	51	27.76	199	1.91	5846	2 8 .				
	45	31.54	226	1.74	5833	3 2 .				
	39	35.83	257	1.63	6000	3 6 .				
	36	39.46	283	1.48	6000	4 0 .				
31	45.39	326	1.33	6000	4 5 .					
29	49.35	353	1.25	6000	5 0 .					
24	59.24	422	1.04	6000	6 3 .					
20	71.09	507	0.87	6000	7 1 .					
50	28.37	203	2.86	7070	K 0 5 3 2 2 8 . _ M _ _ _ _ 1 . 1 A - -	45.5	90S			
43	32.99	236	2.56	7262	3 2 .					
38	36.91	265	2.4	7370	3 6 .					
36	39.34	283	2.24	7345	4 0 .					
30	46.63	335	1.96	7295	4 5 .					
28	49.78	357	1.84	7266	5 0 .					
23	61.78	443	1.49	7346	6 3 .					
19	72.85	521	1.26	7085	7 1 .					
18	79.77	569	1.16	7004	8 0 .					
14	97.76	696	0.95	7340	1 0 0					
13	108.96	778	0.85	6740	1 1 2					
12	118.4	818	0.81	7496	K 0 5 5 2 1 2 5 _ M _ _ _ _ 1 . 1 A - -					
44	32.38	232	3.55	7864	K 0 6 3 2 3 2 . _ M _ _ _ _ 1 . 1 A - -			53.5	90S	
39	36.22	260	3.17	7844	3 6 .					
37	38.61	277	2.98	7830	4 0 .					
31	45.76	328	2.52	7987	4 5 .					
29	48.86	350	2.36	7973	5 0 .					
23	60.62	435	1.9	8000	6 3 .					
20	71.49	511	1.62	8000	7 1 .					
18	78.28	560	1.48	8000	8 0 .					
15	95.93	687	1.2	8000	1 0 0					
13	106.93	760	1.09	8000	1 1 2					
12	116.19	808	1.02	8000	K 0 6 5 2 1 2 5 _ M _ _ _ _ 1 . 1 A - -					
10	140.12	978	0.84	8000	1 4 0					
22	62.94	449	3.56	15000	K 0 7 3 2 6 3 . _ M _ _ _ _ 1 . 1 A - -	72.5	90S			
19	75.07	535	2.99	15000	7 1 .					
17	82.21	585	2.73	15000	8 0 .					
14	98.65	701	2.28	14720	1 0 0					
12	113.5	808	1.98	15000	1 1 2					
11	126.11	892	1.55	15000	1 2 5					
12	120.29	846	1.97	15000	K 0 7 5 2 1 2 5 _ M _ _ _ _ 1 . 1 A - -					
11	133.48	942	1.77	15000	1 4 0					
10	147.09	1038	1.61	15000	1 6 0					
6.7	211.12	1485	1.12	15000	2 0 0					
6	233.36	1644	1.02	15000	2 5 0					
5.3	265.1	1868	0.89	15000	2 8 0					
14	98.08	700	3.83	21500	K 0 8 3 2 1 0 0 _ M _ _ _ _ 1 . 1 A - -	127.5	90S			
13	107.1	763	3.51	21500	1 1 2					
11	123.33	876	3.06	21500	1 2 5					
3.1	462.28	3234	0.84	15674	K 0 8 5 2 4 5 0 _ M _ _ _ _ 1 . 1 A - -	153.5	90S			
2.5	562.75	3946	0.96	34000	K 0 9 5 1 5 6 0 _ M _ _ _ _ 1 . 1 A - -					
2.2	654.52	4589	0.82	34000	6 3 0					
2.7	514.73	3611	1.99	43100	K 1 0 5 1 5 0 0 _ M _ _ _ _ 1 . 1 A - -	335.5	90S			
2.5	566.2	3972	1.81	43100	5 6 0					
2.2	650.62	4563	1.57	43100	6 3 0					
2	722.98	5061	1.42	43100	7 0 0					
1.8	783.15	5477	1.31	43100	8 0 0					
1.6	904.27	6328	1.14	43100	9 0 0					
1.4	979.53	6848	1.05	43100	1 0 C					
1.2	1170.88	8187	0.88	43100	1 1 C					
1.1	1268.32	8860	0.81	43100	1 2 C					
2.7	531.11	3733	3.24	61368	K 1 2 5 1 5 0 0 _ M _ _ _ _ 1 . 1 A - -					
2.4	584.22	4105	2.95	61368	5 6 0					
2.1	671.32	4715	2.56	61368	6 3 0					
1.9	756.72	5311	2.28	61368	7 0 0					
1.7	808.78	5672	2.19	61293	8 0 0					
1.5	946.46	6638	1.82	61368	9 0 0					
1.4	1011.58	7090	1.75	61293	1 0 C					
1.2	1140.25	7985	1.56	61293	1 1 C					
1.2	1225.51	8586	1.41	61368	1 2 C					
0.93	1518.59	10620	1.17	61293	1 4 C					
0.82	1711.76	11964	1.04	61293	1 6 C					
0.78	1811.28	12650	0.98	61293	1 8 C					
0.69	2041.68	14252	0.87	61293	2 0 C					

NOTE
Other output speeds are available using 2 and 8 pole motors - Consult Textron Power Transmission

0205

1.1 kW	N2 R/MIN	i	M2 Nm	Fm	N	Unit Designation	Kg	Motor Size
	Output Speed	Ratio	Output Torque	Service Factor	Overhung Load	Column Entry <input type="text" value="1"/> Through <input type="text" value="20"/> Spaces to be filled when entering order	Weight of base mount unit	
	6 POLE							
	111	8.33	91	1.64	4140	K 0 3 3 2 8 . 0 _ M _ _ _ _ 1 . 1 C - -	31.5	90L
	82	11.25	123	1.38	4370	1 1 .		
	72	12.8	140	1.26	4450	1 2 .		
	64	14.5	158	1.17	4520	1 4 .		
	50	18.54	203	0.98	4620	1 8 .		
	46	19.98	219	0.93	4640	2 0 .		
	115	8.05	88	3.03	5850	K 0 4 3 2 8 . 0 _ M _ _ _ _ 1 . 1 C - -	36.5	90L
	82	11.3	124	2.49	6000	1 1 .		
	74	12.45	136	2.35	6000	1 2 .		
	65	14.14	155	2.15	6000	1 4 .		
	52	17.95	197	1.83	6000	1 8 .		
	45	20.4	223	1.68	6000	2 0 .		
	37	25.03	273	1.46	6000	2 5 .		
	33	27.76	305	1.35	6000	2 8 .		
	29	31.54	344	1.25	6000	3 2 .		
	26	35.83	390	1.13	6000	3 6 .		
	23	39.46	430	1.02	6000	4 0 .		
	20	45.39	498	0.88	6000	4 5 .		
	19	49.35	539	0.82	6000	5 0 .		
	33	28.37	310	2.03	7331	K 0 5 3 2 2 8 . _ M _ _ _ _ 1 . 1 C - -	46.5	90L
	28	32.99	361	1.82	7271	3 2 .		
	25	36.91	404	1.63	7213	3 6 .		
	24	39.34	432	1.52	7172	4 0 .		
	20	46.63	511	1.29	7041	4 5 .		
	19	49.78	545	1.21	6978	5 0 .		
	15	61.78	677	0.97	6680	6 3 .		
	13	72.85	796	0.83	5979	7 1 .		
	33	27.84	305	2.71	8000	K 0 6 3 2 2 8 . _ M _ _ _ _ 1 . 1 C - -	54.5	90L
	29	32.38	354	2.33	8000	3 2 .		
	26	36.22	396	2.08	8000	3 6 .		
	24	38.61	423	1.95	8000	4 0 .		
	20	45.76	502	1.65	8000	4 5 .		
	19	48.86	536	1.54	8000	5 0 .		
	15	60.62	664	1.24	8000	6 3 .		
	13	71.49	780	1.06	7708	7 1 .		
	12	78.28	858	0.96	8000	8 0 .		
	19	48.01	523	3.06	15000	K 0 7 3 2 4 5 . _ M _ _ _ _ 1 . 1 C - -	73.5	90L
	17	54.28	593	2.7	15000	5 0 .		
	15	62.94	686	2.33	15000	6 3 .		
	12	75.07	815	1.96	14293	7 1 .		
	11	82.21	895	1.79	14128	8 0 .		
	9.4	98.65	1068	1.5	13590	1 0 0		
	8.2	113.5	1234	1.3	13733	1 1 2		
	7.3	126.11	1358	1.02	14710	1 2 5		
	7.7	120.29	1293	1.29	15000	K 0 7 5 2 1 2 5 _ M _ _ _ _ 1 . 1 C - -	85.5	90L
	6.9	133.48	1439	1.16	15000	1 4 0		
	6.3	147.09	1586	1.05	15000	1 6 0		
	13	72.86	792	3.38	21500	K 0 8 3 2 7 1 . _ M _ _ _ _ 1 . 1 C - -	128.5	90L
	12	80.03	871	3.07	21500	8 0 .		
	9.4	98.08	1066	2.51	21500	1 0 0		
	8.6	107.1	1163	2.3	20165	1 1 2		
	7.5	123.33	1336	2.01	19856	1 2 5		
	7.7	120.31	1303	2.9	34000	K 0 9 3 1 1 2 5 _ M _ _ _ _ 1 . 1 C - -	181.5	90L
	7.2	128.92	1397	3.01	34000	1 4 0		
	6.4	144.96	1565	2.69	34000	1 6 0		
	1.8	514.73	5520	1.3	43100	K 1 0 5 1 5 0 0 _ M _ _ _ _ 1 . 1 C - -	336.5	90L
	1.6	566.2	6070	1.18	43100	5 6 0		
	1.4	650.62	6972	1.03	43100	6 3 0		
	1.3	722.98	7735	0.93	43100	7 0 0		
	1.2	783.15	8372	0.86	43100	8 0 0		
	1.7	531.11	5699	2.12	61368	K 1 2 5 1 5 0 0 _ M _ _ _ _ 1 . 1 C - -	496.5	90L
	1.6	584.22	6267	1.93	61368	5 6 0		
	1.4	671.32	7197	1.68	61368	6 3 0		
	1.2	756.72	8109	1.49	61368	7 0 0		
	1.1	808.78	8660	1.43	61293	8 0 0		
	0.98	946.46	10132	1.19	61368	9 0 0		
	0.91	1011.58	10820	1.15	61293	1 0 C		
	0.81	1140.25	12190	1.02	61293	1 1 C		
	0.75	1225.51	13098	0.92	61368	1 2 C		

NOTE
Other output speeds are available using 2 and 8 pole motors - Consult Textron Power Transmission

0205

1.5 kW	N2 R/MIN	i	M2 Nm	Fm	N	Unit Designation	Kg	Motor Size
	Output Speed	Ratio	Output Torque	Service Factor	Overhung Load	Column Entry <input type="text" value="1"/> Through <input type="text" value="20"/> Spaces to be filled when entering order	Weight of base mount unit	
	4 POLE							
	171	8.33	80	1.7	3590	K 0 3 3 2 8 . 0 _ M _ _ _ _ 1 . 5 A _ _	31.5	90L
	126	11.25	109	1.42	3774	1 1 .		
	111	12.8	124	1.31	3841	1 2 .		
	98	14.5	141	1.21	3895	1 4 .		
	77	18.54	180	1.02	3970	1 8 .		
	71	19.98	195	0.97	3980	2 0 .		
	176	8.05	78	3.15	5080	K 0 4 3 2 8 . 0 _ M _ _ _ _ 1 . 5 A _ _	36.5	90L
	126	11.3	109	2.59	5514	1 1 .		
	114	12.45	121	2.44	5639	1 2 .		
	100	14.14	137	2.25	5745	1 4 .		
	79	17.95	174	1.91	5715	1 8 .		
	70	20.4	198	1.75	5746	2 0 .		
	57	25.03	243	1.52	5740	2 5 .		
	51	27.76	270	1.41	5735	2 8 .		
	45	31.54	306	1.29	5712	3 2 .		
	40	35.83	348	1.2	6000	3 6 .		
	36	39.46	383	1.09	6000	4 0 .		
	31	45.39	442	0.99	6000	4 5 .		
	29	49.35	479	0.92	6000	5 0 .		
	50	28.37	276	2.12	6512	K 0 5 3 2 2 8 . _ M _ _ _ _ 1 . 5 A _ _	46.5	90L
	43	32.99	320	1.89	6613	3 2 .		
	38	36.91	359	1.78	6650	3 6 .		
	36	39.34	383	1.65	6596	4 0 .		
	30	46.63	453	1.45	6490	4 5 .		
	29	49.78	484	1.36	6427	5 0 .		
	23	61.78	600	1.1	6600	6 3 .		
	19	72.85	705	0.93	6420	7 1 .		
	18	79.77	770	0.86	6280	8 0 .		
	51	27.84	270	3.05	7546	K 0 6 3 2 2 8 . _ M _ _ _ _ 1 . 5 A _ _	54.5	90L
	44	32.38	314	2.62	7709	3 2 .		
	39	36.22	352	2.34	7667	3 6 .		
	37	38.61	375	2.2	7637	4 0 .		
	31	45.76	444	1.86	7973	4 5 .		
	29	48.86	474	1.74	7943	5 0 .		
	23	60.62	589	1.4	8000	6 3 .		
	20	71.49	692	1.19	8000	7 1 .		
	18	78.28	758	1.09	8000	8 0 .		
	15	95.93	931	0.89	8000	1 0 0		
	13	106.93	1029	0.8	8000	1 1 2		
	30	48.01	465	3.44	15000	K 0 7 3 2 4 5 . _ M _ _ _ _ 1 . 5 A _ _	73.5	90L
	26	54.28	525	3.04	15000	5 0 .		
	23	62.94	608	2.63	14503	6 3 .		
	19	75.07	725	2.21	14434	7 1 .		
	17	82.21	793	2.02	14393	8 0 .		
	14	98.65	949	1.68	14400	1 0 0		
	13	113.5	1094	1.46	15000	1 1 2		
	11	126.11	1207	1.14	15000	1 2 5		
	12	120.29	1145	1.46	15000	K 0 7 5 2 1 2 5 _ M _ _ _ _ 1 . 5 A _ _	85.5	90L
	11	133.48	1275	1.31	15000	1 4 0		
	10	147.09	1405	1.19	15000	1 6 0		
	6.7	211.12	2011	0.83	15000	2 0 0		
	19	72.86	704	3.81	21500	K 0 8 3 2 7 1 . _ M _ _ _ _ 1 . 5 A _ _	128.5	90L
	18	80.03	773	3.47	21500	8 0 .		
	14	98.08	948	2.83	20713	1 0 0		
	13	107.1	1033	2.59	20672	1 1 2		
	12	123.33	1186	2.26	20437	1 2 5		
	13	106.99	1033	3.66	34000	K 0 9 3 1 1 1 2 _ M _ _ _ _ 1 . 5 A _ _	181.5	90L
	12	120.31	1157	3.26	34000	1 2 5		
	11	128.92	1240	3.39	34000	1 4 0		
	10	144.96	1389	3.03	34000	1 6 0		
	2.8	514.73	4889	1.47	43100	K 1 0 5 1 5 0 0 _ M _ _ _ _ 1 . 5 A _ _	336.5	90L
	2.5	566.2	5378	1.34	43100	5 6 0		
	2.2	650.62	6179	1.16	43100	6 3 0		
	2	722.98	6853	1.05	43100	7 0 0		
	1.8	783.15	7416	0.97	43100	8 0 0		
	1.6	904.27	8568	0.84	43100	9 0 0		
	2.7	531.11	5054	2.39	61368	K 1 2 5 1 5 0 0 _ M _ _ _ _ 1 . 5 A _ _	496.5	90L
	2.4	584.22	5559	2.18	61368	5 6 0		
	2.1	671.32	6385	1.89	61368	6 3 0		
	1.9	756.72	7191	1.68	61368	7 0 0		
	1.8	808.78	7681	1.62	61293	8 0 0		
	1.5	946.46	8989	1.35	61368	9 0 0		
	1.4	1011.58	9600	1.29	61293	1 0 C		
	1.2	1140.25	10812	1.15	61293	1 1 C		
	1.2	1225.51	11625	1.04	61368	1 2 C		
	0.94	1518.59	14380	0.86	61293	1 4 C		

NOTE
Other output speeds are available using 2 and 8 pole motors - Consult Textron Power Transmission

0205

1.5 kW	N2 R/MIN	i	M2 Nm	Fm	N	Unit Designation	Kg	Motor Size		
	Output Speed	Ratio	Output Torque	Service Factor	Overhung Load	Column Entry 1 Through 20 Spaces to be filled when entering order	Weight of base mount unit			
6 POLE	72	12.78	191	2.63	6140	K 0 5 3 2 1 2 . _ M _ - _ _ 1 . 5 C - -	59	100L		
	64	14.35	214	2.43	6270	1 4 .				
	51	18.22	272	2.06	6480	1 8 .				
	45	20.66	309	1.88	6570	2 0 .				
	38	24.64	368	1.65	6670	2 5 .				
	33	28.37	424	1.49	6567	2 8 .				
	28	32.99	492	1.34	6437	3 2 .				
	25	36.91	551	1.19	6313	3 6 .				
	24	39.34	589	1.12	6225	4 0 .				
	20	46.63	697	0.94	5946	4 5 .				
	19	49.78	743	0.89	5812	5 0 .				
	52	17.88	267	3.02	8000	K 0 6 3 2 1 8 . _ M _ - _ _ 1 . 5 C - -			67	100L
	46	20.27	303	2.72	8000	2 0 .				
	38	24.18	362	2.28	8000	2 5 .				
	33	27.84	416	1.98	8000	2 8 .				
	29	32.38	483	1.71	8000	3 2 .				
	26	36.22	540	1.53	8000	3 6 .				
	24	38.61	577	1.43	8000	4 0 .				
	20	45.76	684	1.21	8000	4 5 .				
	19	48.86	731	1.13	8000	5 0 .				
	15	60.62	906	0.91	8000	6 3 .				
	28	33.52	500	3.2	15000	K 0 7 3 2 3 2 . _ M _ - _ _ 1 . 5 C - -	85	100L		
	24	38.01	566	2.83	15000	3 6 .				
	22	41.92	624	2.56	15000	4 0 .				
	19	48.01	713	2.24	14282	4 5 .				
	17	54.28	808	1.98	14194	5 0 .				
	15	62.94	936	1.71	14286	6 3 .				
	12	75.07	1111	1.44	13486	7 1 .				
	11	82.21	1220	1.31	13133	8 0 .				
	9.4	98.65	1456	1.1	12564	1 0 0				
	8.2	113.5	1682	0.95	12812	1 1 2				
	18	51.54	766	3.49	21500	K 0 8 3 2 5 0 . _ M _ - _ _ 1 . 5 C - -			140	100L
	15	62.47	929	2.88	21500	6 3 .				
	13	72.86	1080	2.48	20481	7 1 .				
	12	80.03	1188	2.25	20323	8 0 .				
	9.4	98.08	1453	1.84	20010	1 0 0				
	8.6	107.1	1586	1.69	18640	1 1 2				
	7.5	123.33	1821	1.47	17978	1 2 5				
	7	132.19	1930	1.4	15674	K 0 8 5 2 1 2 5 _ M _ - _ _ 1 . 5 C - -	166	100L		
	6.4	144.67	2111	1.28	15674	1 4 0				
	5.7	163.67	2383	1.14	15674	1 6 0				
	4.5	203.4	2968	0.91	15674	2 0 0				
	11	84.89	1257	3.35	34000	K 0 9 3 1 9 0 . _ M _ - _ _ 1 . 5 C - -	193	100L		
	10	93.71	1388	3.03	34000	1 0 0				
	8.6	106.99	1586	2.38	34000	1 1 2				
7.7	120.31	1777	2.13	34000	1 2 5					
7.2	128.92	1905	2.21	34000	1 4 0					
6.4	144.96	2134	1.97	34000	1 6 0					
5.7	160.93	2355	1.6	34000	K 0 9 5 1 1 6 0 _ M _ - _ _ 1 . 5 C - -	224			100L	
4.1	226.25	3311	1.14	34000	2 0 0					
3.6	253.59	3711	1.02	34000	2 5 0					
3.3	281.74	4116	0.92	34000	2 8 0					
2.9	316.25	4619	0.82	34000	3 2 0					
6.4	144.88	2144	3.35	43400	K 1 0 3 1 1 6 0 _ M _ - _ _ 1 . 5 C - -	317	100L			
1.8	514.73	7527	0.95	43100	K 1 0 5 1 5 0 0 _ M _ - _ _ 1 . 5 C - -			349	100L	
1.6	566.2	8278	0.87	43100	5 6 0					
1.7	531.11	7772	1.56	61368	K 1 2 5 1 5 0 0 _ M _ - _ _ 1 . 5 C - -	509	100L			
1.6	584.22	8546	1.42	61368	5 6 0					
1.4	671.32	9815	1.23	61368	6 3 0					
1.2	756.72	11058	1.09	61368	7 0 0					
1.1	808.78	11810	1.05	61293	8 0 0					
0.98	946.46	13817	0.88	61368	9 0 0					
0.91	1011.58	14755	0.84	61293	1 0 C					

NOTE
Other output speeds are available using 2 and 8 pole motors - Consult Textron Power Transmission

0205

2.2 kW	N2 R/MIN	i	M2 Nm	Fm	N	Unit Designation	Kg	Motor Size
	Output Speed	Ratio	Output Torque	Service Factor	Overhung Load	Column Entry <input type="text" value="1"/> Through <input type="text" value="20"/> Spaces to be filled when entering order	Weight of base mount unit	
	4 POLE							
	171	8.33	118	1.16	3230	K 0 3 3 2 8 . 0 _ M _ _ _ 2 . 2 K - -	37	90LA
	126	11.25	160	0.97	3290	1 1 .		
	111	12.8	183	0.89	3290	1 2 .		
	98	14.5	207	0.82	3270	1 4 .		
	176	8.05	114	2.15	4800	K 0 4 3 2 8 . 0 _ M _ _ _ 2 . 2 K - -	42	90LA
	126	11.3	161	1.76	5120	1 1 .		
	114	12.45	177	1.66	5200	1 2 .		
	100	14.14	201	1.53	5300	1 4 .		
	79	17.95	256	1.3	5450	1 8 .		
	70	20.4	291	1.19	5510	2 0 .		
	57	25.03	356	1.04	5550	2 5 .		
	51	27.76	396	0.96	5540	2 8 .		
	45	31.54	449	0.88	5500	3 2 .		
	176	8.11	115	3.42	4800	K 0 5 3 2 8 . 0 _ M _ _ _ 2 . 2 A - -	59	100L
	125	11.4	162	2.77	5126	1 1 .		
	111	12.78	181	2.56	5223	1 2 .		
	99	14.35	204	2.38	5310	1 4 .		
	78	18.22	259	2	5460	1 8 .		
	69	20.66	293	1.83	5512	2 0 .		
	58	24.64	350	1.61	5541	2 5 .		
	50	28.37	403	1.45	5535	2 8 .		
	43	32.99	468	1.3	5477	3 2 .		
	39	36.91	525	1.22	5390	3 6 .		
	36	39.34	560	1.13	5286	4 0 .		
	31	46.63	663	0.99	5081	4 5 .		
	29	49.78	708	0.93	4959	5 0 .		
	50	28.37	404	1.44	5535	K 0 5 3 2 2 8 . _ M _ _ _ 2 . 2 K - -	52	90LA
	43	32.99	470	1.29	5477	3 2 .		
	38	36.91	526	1.21	5390	3 6 .		
	36	39.34	562	1.13	5286	4 0 .		
	30	46.63	665	0.99	5081	4 5 .		
	29	49.78	710	0.93	4959	5 0 .		
	114	12.54	178	3.74	7760	K 0 6 3 2 1 2 . _ M _ _ _ 2 . 2 A - -	67	100L
	101	14.08	200	3.47	7970	1 4 .		
	80	17.88	254	2.94	8000	1 8 .		
	70	20.27	288	2.69	8000	2 0 .		
	59	24.18	344	2.37	8000	2 5 .		
	51	27.84	395	2.09	7123	2 8 .		
	44	32.38	459	1.8	7437	3 2 .		
	39	36.22	515	1.6	7357	3 6 .		
	37	38.61	549	1.51	7299	4 0 .		
	31	45.76	649	1.27	7948	4 5 .		
	29	48.86	693	1.19	7890	5 0 .		
	24	60.62	861	0.96	8000	6 3 .		
	20	71.49	1011	0.82	8000	7 1 .		
	113	12.54	179	3.73	7760	K 0 6 3 2 1 2 . _ M _ _ _ 2 . 2 K - -	60	90LA
	101	14.08	201	3.46	7970	1 4 .		
	79	17.88	255	2.93	8000	1 8 .		
	70	20.27	289	2.68	8000	2 0 .		
	59	24.18	345	2.36	8000	2 5 .		
	51	27.84	397	2.08	7123	2 8 .		
	44	32.38	461	1.79	7437	3 2 .		
	39	36.22	517	1.6	7357	3 6 .		
	37	38.61	551	1.5	7299	4 0 .		
	31	45.76	651	1.27	7948	4 5 .		
	29	48.86	695	1.19	7890	5 0 .		
	23	60.62	864	0.96	8000	6 3 .		
	20	71.49	1015	0.81	8000	7 1 .		
	54	26.52	376	3.95	13300	K 0 7 3 2 2 5 . _ M _ _ _ 2 . 2 A - -	85	100L
	49	29.17	414	3.69	13500	2 8 .		
	43	33.52	475	3.32	13900	3 2 .		
	37	38.01	538	2.97	14300	3 6 .		
	34	41.92	593	2.69	14600	4 0 .		
	30	48.01	679	2.35	13982	4 5 .		
	26	54.28	768	2.08	13900	5 0 .		
	23	62.94	888	1.8	13634	6 3 .		
	19	75.07	1059	1.51	13444	7 1 .		
	17	82.21	1159	1.38	13331	8 0 .		
	14	98.65	1388	1.15	13840	1 0 0		
	13	113.5	1598	1	15000	1 1 2		
	54	26.52	378	3.94	13300	K 0 7 3 2 2 5 . _ M _ _ _ 2 . 2 K - -	79	90LA
	49	29.17	416	3.68	13500	2 8 .		
	42	33.52	477	3.31	13900	3 2 .		
	37	38.01	540	2.96	14300	3 6 .		
	34	41.92	596	2.68	14600	4 0 .		
	30	48.01	682	2.35	13982	4 5 .		
	26	54.28	771	2.07	13900	5 0 .		
	23	62.94	891	1.79	13634	6 3 .		
	19	75.07	1063	1.5	13444	7 1 .		
	17	82.21	1163	1.38	13331	8 0 .		
	14	98.65	1393	1.15	13840	1 0 0		
	13	113.5	1604	1	15000	1 1 2		

NOTE
Other output speeds are available using 2 and 8 pole motors - Consult Textron Power Transmission

0205

2.2 kW	N2 R/MIN	i	M2 Nm	Fm	N	Unit Designation	Kg	Motor Size
	Output Speed	Ratio	Output Torque	Service Factor	Overhung Load	Column Entry <input type="text" value="1"/> Through <input type="text" value="20"/> Spaces to be filled when entering order	Weight of base mount unit	
	4 POLE							
	12	120.29	1680	0.99	15000	K 0 7 5 2 1 2 5 _ M _ _ _ _ 2 . 2 K - -	91	90LA
	11	133.48	1871	0.89	15000	1 4 0		
	10	147.09	2062	0.81	15000	1 6 0		
	28	51.54	729	3.67	18855	K 0 8 3 2 5 0 . _ M _ _ _ _ 2 . 2 A - -	140	100L
	23	62.47	883	3.03	19587	6 3 .		
	20	72.86	1029	2.6	19997	7 1 .		
	18	80.03	1129	2.37	19929	8 0 .		
	15	98.08	1385	1.93	19337	1 0 0		
	13	107.1	1511	1.77	19224	1 1 2		
	12	123.33	1733	1.55	18579	1 2 5		
	11	132.19	1830	1.48	15674	K 0 8 5 2 1 2 5 _ M _ _ _ _ 2 . 2 A - -	166	100L
	10	144.67	2000	1.36	15674	1 4 0		
	8.7	163.67	2256	1.2	15674	1 6 0		
	7	203.4	2812	0.96	15674	2 0 0		
	18	77.78	1100	3.44	34000	K 0 9 3 1 8 0 . _ M _ _ _ _ 2 . 2 A - -	193	100L
	17	84.89	1196	3.52	34000	9 0 .		
	15	93.71	1319	3.19	34000	1 0 0		
	13	106.99	1511	2.5	34000	1 1 2		
	12	120.31	1692	2.23	34000	1 2 5		
	11	128.92	1812	2.32	34000	1 4 0		
	10	144.96	2031	2.07	34000	1 6 0		
	8.9	160.93	2234	1.69	34000	K 0 9 5 1 1 6 0 _ M _ _ _ _ 2 . 2 A - -	224	100L
	6.3	226.25	3141	1.2	34000	2 0 0		
	5.6	253.59	3520	1.07	34000	2 5 0		
	5.1	281.74	3902	0.97	34000	2 8 0		
	4.5	316.25	4380	0.86	34000	3 2 0		
	11	134.85	1900	3.78	43405	K 1 0 3 1 1 4 0 _ M _ _ _ _ 2 . 2 A - -	317	100L
	10	144.88	2039	3.52	43405	1 6 0		
	2.8	514.73	7146	1.01	43100	K 1 0 5 1 5 0 0 _ M _ _ _ _ 2 . 2 A - -	349	100L
	2.5	566.2	7860	0.91	43100	5 6 0		
	2.8	514.73	7171	1	43100	K 1 0 5 1 5 0 0 _ M _ _ _ _ 2 . 2 K - -	342	90LA
	2.5	566.2	7888	0.91	43100	5 6 0		
	2.7	531.11	7387	1.64	61368	K 1 2 5 1 5 0 0 _ M _ _ _ _ 2 . 2 A - -	509	100L
	2.4	584.22	8124	1.49	61368	5 6 0		
	2.1	671.32	9332	1.3	61368	6 3 0		
	1.9	756.72	10510	1.15	61368	7 0 0		
	1.8	808.78	11226	1.11	61293	8 0 0		
	1.5	946.46	13137	0.92	61368	9 0 0		
	1.4	1011.58	14031	0.89	61293	1 0 C		
	2.7	531.11	7413	1.63	61368	K 1 2 5 1 5 0 0 _ M _ _ _ _ 2 . 2 K - -	502	90LA
	2.4	584.22	8153	1.48	61368	5 6 0		
	2.1	671.32	9365	1.29	61368	6 3 0		
	1.9	756.72	10547	1.15	61368	7 0 0		
	1.8	808.78	11266	1.1	61293	8 0 0		
	1.5	946.46	13184	0.92	61368	9 0 0		
	1.4	1011.58	14081	0.88	61293	1 0 C		

NOTE
Other output speeds are available using 2 and 8 pole motors - Consult Textron Power Transmission

0205

2.2 kW	N2 R/MIN	i	M2 Nm	Fm	N	Unit Designation	Kg	Motor Size
	Output Speed	Ratio	Output Torque	Service Factor	Overhung Load	Column Entry <input type="text" value="1"/> Through <input type="text" value="20"/> Spaces to be filled when entering order	Weight of base mount unit	
	6 POLE							
	117	8.11	173	2.47	5180	K 0 5 3 2 8 . 0 _ M _ _ _ _ 2 . 2 C - -	66	112M
	83	11.4	243	1.99	5420	1 1 .		
	74	12.78	273	1.84	5480	1 2 .		
	66	14.35	307	1.7	5520	1 4 .		
	52	18.22	389	1.44	5530	1 8 .		
	46	20.66	442	1.31	5500	2 0 .		
	39	24.64	526	1.16	5380	2 5 .		
	33	28.37	605	1.04	5230	2 8 .		
	29	32.99	703	0.94	4980	3 2 .		
	26	36.91	787	0.84	4740	3 6 .		
	119	7.96	170	3.58	7680	K 0 6 3 2 8 . 0 _ M _ _ _ _ 2 . 2 C - -	74	112M
	85	11.19	239	2.89	8000	1 1 .		
	76	12.54	268	2.69	8000	1 2 .		
	67	14.08	300	2.49	8000	1 4 .		
	53	17.88	382	2.11	8000	1 8 .		
	47	20.27	433	1.91	8000	2 0 .		
	39	24.18	517	1.6	8000	2 5 .		
	34	27.84	595	1.39	8000	2 8 .		
	29	32.38	691	1.2	8000	3 2 .		
	26	36.22	772	1.07	8000	3 6 .		
	25	38.61	824	1	8000	4 0 .		
	21	45.76	977	0.85	8000	4 5 .		
	36	26.52	564	2.83	14400	K 0 7 3 2 2 5 . _ M _ _ _ _ 2 . 2 C - -	92	112M
	33	29.17	621	2.57	14700	2 8 .		
	28	33.52	714	2.24	13951	3 2 .		
	25	38.01	808	1.98	13860	3 6 .		
	23	41.92	891	1.79	13769	4 0 .		
	20	48.01	1019	1.57	13027	4 5 .		
	18	54.28	1154	1.39	12785	5 0 .		
	15	62.94	1337	1.2	13038	6 3 .		
	13	75.07	1587	1.01	12073	7 1 .		
	12	82.21	1743	0.92	11390	8 0 .		
	26	36.88	783	3.42	19200	K 0 8 3 2 3 6 . _ M _ _ _ _ 2 . 2 C - -	147	112M
	24	40.36	858	3.12	19500	4 0 .		
	21	45.66	970	2.76	20000	4 5 .		
	18	51.54	1095	2.45	19918	5 0 .		
	15	62.47	1326	2.02	19682	6 3 .		
	13	72.86	1543	1.74	18700	7 1 .		
	12	80.03	1697	1.58	18265	8 0 .		
	10	98.08	2075	1.29	17403	1 0 0		
	8.9	107.1	2265	1.18	15972	1 1 2		
	7.7	123.33	2601	1.03	14691	1 2 5		
	7.2	132.19	2757	0.98	15674	K 0 8 5 2 1 2 5 _ M _ _ _ _ 2 . 2 C - -	173	112M
	6.6	144.67	3015	0.9	15674	1 4 0		
	16	60.1	1273	3.31	34000	K 0 9 3 1 6 3 . _ M _ _ _ _ 2 . 2 C - -	200	112M
	13	70.45	1495	2.53	34000	7 1 .		
	12	77.78	1650	2.29	34000	8 0 .		
	11	84.89	1796	2.34	34000	9 0 .		
	10	93.71	1982	2.12	34000	1 0 0		
	8.9	106.99	2265	1.67	34000	1 1 2		
	7.9	120.31	2538	1.49	34000	1 2 5		
	7.4	128.92	2720	1.55	34000	1 4 0		
	6.6	144.96	3048	1.38	34000	1 6 0		
	5.9	160.93	3364	1.12	34000	K 0 9 5 1 1 6 0 _ M _ _ _ _ 2 . 2 C - -	231	112M
	8.5	112.03	2375	3.03	43400	K 1 0 3 1 1 1 2 _ M _ _ _ _ 2 . 2 C - -	324	112M
	7.9	120.36	2549	2.82	43400	1 2 5		
	7	134.85	2854	2.52	43400	1 4 0		
	6.6	144.88	3062	2.35	43330	1 6 0		
	6.5	145.85	3082	3.99	61700	K 1 2 3 1 1 6 0 _ M _ _ _ _ 2 . 2 C - -	458	112M
	1.8	531.11	11099	1.09	61368	K 1 2 5 1 5 0 0 _ M _ _ _ _ 2 . 2 C - -	516	112M
	1.6	584.22	12205	0.99	61368	5 6 0		
	1.4	671.32	14017	0.86	61368	6 3 0		

NOTE
Other output speeds are available using 2 and 8 pole motors - Consult Textron Power Transmission

0205

3.0 kW	N2 R/MIN	i	M2 Nm	Fm	N	Unit Designation	Kg	Motor Size
	Output Speed	Ratio	Output Torque	Service Factor	Overhung Load	Column Entry <input type="text" value="1"/> Through <input type="text" value="20"/> Spaces to be filled when entering order	Weight of base mount unit	
	4 POLE							
	176	8.11	157	2.51	4480	K 0 5 3 2 8 . 0 _ M _ _ _ 3 . 0 A _ _	59	100L
	125	11.4	220	2.03	4676	1 1 .		
	111	12.78	247	1.88	4718	1 2 .		
	99	14.35	278	1.74	4743	1 4 .		
	78	18.22	353	1.47	4740	1 8 .		
	69	20.66	400	1.34	4693	2 0 .		
	58	24.64	477	1.18	4571	2 5 .		
	50	28.37	550	1.06	4420	2 8 .		
	43	32.99	638	0.95	4180	3 2 .		
	39	36.91	716	0.89	3950	3 6 .		
	36	39.34	764	0.83	3790	4 0 .		
	179	7.96	153	3.64	8000	K 0 6 3 2 8 . 0 _ M _ _ _ 3 . 0 A _ _	67	100L
	127	11.19	217	2.95	8000	1 1 .		
	114	12.54	243	2.75	7333	1 2 .		
	101	14.08	273	2.55	7490	1 4 .		
	80	17.88	347	2.16	7483	1 8 .		
	70	20.27	394	1.97	7452	2 0 .		
	59	24.18	469	1.74	7384	2 5 .		
	51	27.84	539	1.53	6640	2 8 .		
	44	32.38	627	1.32	7127	3 2 .		
	39	36.22	703	1.18	7003	3 6 .		
	37	38.61	749	1.1	6913	4 0 .		
	31	45.76	885	0.93	7920	4 5 .		
	29	48.86	945	0.87	7830	5 0 .		
	54	26.52	513	2.9	12530	K 0 7 3 2 2 5 . _ M _ _ _ 3 . 0 A _ _	85	100L
	49	29.17	565	2.71	12663	2 8 .		
	43	33.52	648	2.44	12938	3 2 .		
	37	38.01	734	2.18	13207	3 6 .		
	34	41.92	809	1.98	13387	4 0 .		
	30	48.01	926	1.73	12819	4 5 .		
	26	54.28	1048	1.53	12643	5 0 .		
	23	62.94	1211	1.32	12641	6 3 .		
	19	75.07	1445	1.11	12313	7 1 .		
	17	82.21	1580	1.01	12117	8 0 .		
	14	98.65	1893	0.85	13200	1 0 0		
	39	36.88	711	3.77	15200	K 0 8 3 2 3 6 . _ M _ _ _ 3 . 0 A _ _	140	100L
	35	40.36	779	3.44	15200	4 0 .		
	31	45.66	881	3.04	15200	4 5 .		
	28	51.54	995	2.69	17609	5 0 .		
	23	62.47	1204	2.22	18084	6 3 .		
	20	72.86	1403	1.91	18280	7 1 .		
	18	80.03	1540	1.74	18134	8 0 .		
	15	98.08	1889	1.42	17765	1 0 0		
	13	107.1	2060	1.3	17568	1 1 2		
	12	123.33	2364	1.13	16455	1 2 5		
	11	132.19	2495	1.09	15674	K 0 8 5 2 1 2 5 _ M _ _ _ 3 . 0 A _ _	166	100L
	10	144.67	2727	0.99	15674	1 4 0		
	8.7	163.67	3076	0.88	15674	1 6 0		
	24	60.1	1157	3.64	34000	K 0 9 3 1 6 3 . _ M _ _ _ 3 . 0 A _ _	193	100L
	20	70.45	1359	2.78	34000	7 1 .		
	18	77.78	1500	2.52	34000	8 0 .		
	17	84.89	1630	2.58	34000	9 0 .		
	15	93.71	1799	2.34	34000	1 0 0		
	13	106.99	2060	1.83	34000	1 1 2		
	12	120.31	2307	1.64	34000	1 2 5		
	11	128.92	2471	1.7	34000	1 4 0		
	10	144.96	2769	1.52	34000	1 6 0		
	8.9	160.93	3046	1.24	34000	K 0 9 5 1 1 6 0 _ M _ _ _ 3 . 0 A _ _	224	100L
	6.3	226.25	4283	0.88	34000	2 0 0		
	14	99.7	1925	3.73	43400	K 1 0 3 1 1 0 0 _ M _ _ _ 3 . 0 A _ _	317	100L
	13	112.03	2151	3.34	43400	1 1 2		
	12	120.36	2315	3.11	43400	1 2 5		
	11	134.85	2591	2.77	43359	1 4 0		
	10	144.88	2781	2.58	43359	1 6 0		
	2.7	531.11	10073	1.2	61368	K 1 2 5 1 5 0 0 _ M _ _ _ 3 . 0 A _ _	509	100L
	2.4	584.22	11079	1.09	61368	5 6 0		
	2.1	671.32	12725	0.95	61368	6 3 0		
	1.9	756.72	14333	0.84	61368	7 0 0		
	1.8	808.78	15308	0.81	61293	8 0 0		

NOTE
Other output speeds are available using 2 and 8 pole motors - Consult Textron Power Transmission

0205

3.0 kW	N2 R/MIN	i	M2 Nm	Fm	N	Unit Designation	Kg	Motor Size
	Output Speed	Ratio	Output Torque	Service Factor	Overhung Load	Column Entry <input type="text" value="1"/> Through <input type="text" value="20"/> Spaces to be filled when entering order	Weight of base mount unit	
	6 POLE							
	111	8.6	247	2.87	10700	K 0 7 3 2 8 . 0 _ M _ _ _ 3 . 0 C _ _	111	132SA
	80	11.91	344	2.87	11500	1 1 .		
	71	13.37	386	2.87	11800	1 2 .		
	65	14.71	425	2.87	12100	1 4 .		
	50	19.21	555	2.63	12700	1 8 .		
	44	21.84	632	2.4	12900	2 0 .		
	36	26.52	765	2.09	13253	2 5 .		
	33	29.17	843	1.9	13424	2 8 .		
	28	33.52	968	1.65	12753	3 2 .		
	25	38.01	1096	1.46	12558	3 6 .		
	23	41.92	1209	1.32	12363	4 0 .		
	20	48.01	1382	1.16	11592	4 5 .		
	18	54.28	1566	1.02	11174	5 0 .		
	15	62.94	1813	0.88	11612	6 3 .		
	38	25.35	734	3.65	16700	K 0 8 3 2 2 5 . _ M _ _ _ 3 . 0 C _ _	167	132SA
	33	28.56	825	3.25	17100	2 8 .		
	29	33.24	959	2.79	17500	3 2 .		
	26	36.88	1063	2.52	19200	3 6 .		
	24	40.36	1164	2.3	19500	4 0 .		
	21	45.66	1316	2.04	20000	4 5 .		
	19	51.54	1485	1.8	18110	5 0 .		
	15	62.47	1800	1.49	17605	6 3 .		
	13	72.86	2093	1.28	16663	7 1 .		
	12	80.03	2302	1.16	15912	8 0 .		
	10	98.08	2816	0.95	14424	1 0 0		
	8.9	107.1	3073	0.87	12922	1 1 2		
	21	44.89	1295	2.92	34000	K 0 9 3 1 4 5 . _ M _ _ _ 3 . 0 C _ _	220	132SA
	19	49.87	1439	2.63	34000	5 0 .		
	18	54.09	1555	2.71	34000	5 6 .		
	16	60.1	1727	2.44	34000	6 3 .		
	14	70.45	2028	1.86	34000	7 1 .		
	12	77.78	2239	1.69	34000	8 0 .		
	11	84.89	2436	1.73	34000	9 0 .		
	10	93.71	2689	1.57	34000	1 0 0		
	8.9	106.99	3072	1.23	34000	1 1 2		
	7.9	120.31	3443	1.1	34000	1 2 5		
	7.4	128.92	3690	1.14	34000	1 4 0		
	6.6	144.96	4135	1.02	34000	1 6 0		
	12	82.83	2387	3.01	43400	K 1 0 3 1 8 0 . _ M _ _ _ 3 . 0 C _ _	344	132SA
	11	86.53	2492	2.88	43400	9 0 .		
	10	99.7	2868	2.51	43400	1 0 0		
	8.5	112.03	3221	2.23	43400	1 1 2		
	7.9	120.36	3458	2.08	43400	1 2 5		
	7.1	134.85	3871	1.86	43324	1 4 0		
	6.6	144.88	4153	1.73	43250	1 6 0		
	5.7	166.84	4731	1.52	43100	K 1 0 5 1 1 6 0 _ M _ _ _ 3 . 0 C _ _	375	132SA
	4.1	231.1	6553	1.1	43100	2 0 0		
	3.7	259.6	7360	0.98	43100	2 5 0		
	3.3	285.44	8093	0.89	43100	2 8 0		
	3	317.19	8977	0.8	43100	3 2 0		
	7.9	121.06	3475	3.48	61700	K 1 2 3 1 1 2 5 _ M _ _ _ 3 . 0 C _ _	478	132SA
	7	137.09	3929	3.13	61700	1 4 0		
	6.5	145.85	4181	2.94	61700	1 6 0		
	5.5	172.15	4886	2.48	61368	K 1 2 5 1 1 6 0 _ M _ _ _ 3 . 0 C _ _	535	132SA
	3.6	268.79	7623	1.59	61368	2 0 0		
	4	238.46	6768	1.79	61368	2 5 0		
	3.2	301.94	8562	1.41	61368	2 8 0		
	2.9	331.99	9414	1.28	61368	3 2 0		
	2.5	384.7	10913	1.11	61368	3 6 0		
	2.2	437.38	12404	0.97	61368	4 0 0		
	1.9	493.02	13973	0.87	61368	4 5 0		
	1.8	531.11	15056	0.8	61368	5 0 0		

NOTE
Other output speeds are available using 2 and 8 pole motors - Consult Textron Power Transmission

0205

4.0 kW	N2 R/MIN	i	M2 Nm	Fm	N	Unit Designation	Kg	Motor Size
	Output Speed	Ratio	Output Torque	Service Factor	Overhung Load	Column Entry <input type="text" value="1"/> Through <input type="text" value="20"/> Spaces to be filled when entering order	Weight of base mount unit	
	4 POLE							
	177	8.11	207	1.9	4080	K 0 5 3 2 8 . 0 _ M _ _ _ 4 . 0 A _ _	66	112M
	126	11.4	292	1.53	4113	1 1 .		
	112	12.78	328	1.42	4086	1 2 .		
	100	14.35	368	1.32	4034	1 4 .		
	79	18.22	468	1.11	3840	1 8 .		
	69	20.66	530	1.01	3670	2 0 .		
	58	24.64	632	0.89	3360	2 5 .		
	180	7.96	203	2.75	8000	K 0 6 3 2 8 . 0 _ M _ _ _ 4 . 0 A _ _	74	112M
	128	11.19	287	2.23	8000	1 1 .		
	114	12.54	322	2.07	6800	1 2 .		
	102	14.08	362	1.92	6890	1 4 .		
	80	17.88	459	1.63	6838	1 8 .		
	71	20.27	521	1.49	6767	2 0 .		
	59	24.18	621	1.31	6614	2 5 .		
	52	27.84	714	1.16	6036	2 8 .		
	44	32.38	830	0.99	6740	3 2 .		
	40	36.22	931	0.89	6560	3 6 .		
	37	38.61	991	0.83	6430	4 0 .		
	167	8.6	218	3.24	9380	K 0 7 3 2 8 . 0 _ M _ _ _ 4 . 0 A _ _	92	112M
	121	11.91	303	3.24	10100	1 1 .		
	107	13.37	342	3.24	10300	1 2 .		
	98	14.71	376	3.24	10500	1 4 .		
	75	19.21	491	2.75	11000	1 8 .		
	66	21.84	560	2.5	11200	2 0 .		
	54	26.52	680	2.19	11569	2 5 .		
	49	29.17	748	2.04	11617	2 8 .		
	43	33.52	858	1.84	11737	3 2 .		
	38	38.01	972	1.65	11841	3 6 .		
	34	41.92	1072	1.49	11872	4 0 .		
	30	48.01	1227	1.3	11365	4 5 .		
	26	54.28	1387	1.15	11073	5 0 .		
	23	62.94	1604	1	11400	6 3 .		
	19	75.07	1913	0.84	10900	7 1 .		
	57	25.35	648	3.76	14500	K 0 8 3 2 2 5 . _ M _ _ _ 4 . 0 A _ _	147	112M
	50	28.56	730	3.46	14900	2 8 .		
	43	33.24	850	3.12	15200	3 2 .		
	39	36.88	941	2.85	14811	3 6 .		
	36	40.36	1031	2.6	14811	4 0 .		
	31	45.66	1167	2.3	14811	4 5 .		
	28	51.54	1317	2.03	16051	5 0 .		
	23	62.47	1595	1.68	16205	6 3 .		
	20	72.86	1857	1.44	16134	7 1 .		
	18	80.03	2039	1.31	15890	8 0 .		
	15	98.08	2501	1.07	15800	1 0 0		
	13	107.1	2728	0.98	15500	1 1 2		
	12	123.33	3130	0.86	13800	1 2 5		
	11	132.19	3304	0.82	15674	K 0 8 5 2 1 2 5 _ M _ _ _ 4 . 0 A _ _	173	112M
	32	44.89	1148	3.29	34000	K 0 9 3 1 4 5 . _ M _ _ _ 4 . 0 A _ _	200	112M
	29	49.87	1273	2.97	34000	5 0 .		
	27	54.09	1383	3.04	34000	5 6 .		
	24	60.1	1532	2.75	34000	6 3 .		
	20	70.45	1799	2.1	34000	7 1 .		
	18	77.78	1986	1.9	34000	8 0 .		
	17	84.89	2159	1.95	34000	9 0 .		
	15	93.71	2383	1.77	34000	1 0 0		
	13	106.99	2728	1.39	34000	1 1 2		
	12	120.31	3055	1.24	34000	1 2 5		
	11	128.92	3272	1.29	34000	1 4 0		
	10	144.96	3667	1.15	34000	1 6 0		
	8.9	160.93	4033	0.94	34000	K 0 9 5 1 1 6 0 _ M _ _ _ 4 . 0 A _ _	231	112M
	20	71.89	1839	3.91	43400	K 1 0 3 1 7 1 . _ M _ _ _ 4 . 0 A _ _	324	112M
	17	82.83	2121	3.39	43400	8 0 .		
	17	86.53	2218	3.24	43400	9 0 .		
	14	99.7	2549	2.82	43388	1 0 0		
	13	112.03	2849	2.52	43388	1 1 2		
	12	120.36	3065	2.35	43388	1 2 5		
	11	134.85	3431	2.1	43301	1 4 0		
	10	144.88	3683	1.95	43301	1 6 0		
	8.6	166.84	4182	1.72	43100	K 1 0 5 1 1 6 0 _ M _ _ _ 4 . 0 A _ _	356	112M
	6.2	231.1	5793	1.24	43100	2 0 0		
	5.5	259.6	6507	1.1	43100	2 5 0		
	5	285.44	7156	1	43100	2 8 0		
	4.5	317.19	7933	0.91	43100	3 2 0		
	12	121.06	3095	3.91	61700	K 1 2 3 1 1 2 5 _ M _ _ _ 4 . 0 A _ _	458	112M
	10	137.09	3476	3.54	61700	1 4 0		
	10	145.85	3710	3.32	61700	1 6 0		
	8.3	172.15	4325	2.8	61368	K 1 2 5 1 1 6 0 _ M _ _ _ 4 . 0 A _ _	516	112M
	5.3	268.79	6746	1.79	61368	2 0 0		
	6	238.46	5992	2.02	61368	2 5 0		
	4.8	301.94	7578	1.6	61368	2 8 0		
	4.3	331.99	8333	1.45	61368	3 2 0		
	3.7	384.7	9664	1.25	61368	3 6 0		
	3.3	437.38	10986	1.1	61368	4 0 0		
	2.9	493.02	12372	0.98	61368	4 5 0		
	2.7	531.11	13338	0.91	61368	5 0 0		
	2.5	584.22	14669	0.82	61368	5 6 0		

NOTE
Other output speeds are available using 2 and 8 pole motors - Consult Textron Power Transmission

0205

4.0 kW	N2 R/MIN	i	M2 Nm	Fm	N	Unit Designation	Kg	Motor Size
	Output Speed	Ratio	Output Torque	Service Factor	Overhung Load	Column Entry <input type="text" value="1"/> Through <input type="text" value="20"/> Spaces to be filled when entering order	Weight of base mount unit	
	6 POLE							
	112	8.6	328	2.16	10232	K 0 7 3 2 8 . 0 _ M _ _ _ 4 . 0 C _ _	115	132M
	81	11.91	456	2.16	10868	1 1 .		
	72	13.37	513	2.16	11080	1 2 .		
	65	14.71	564	2.16	11300	1 4 .		
	50	19.21	736	1.98	11660	1 8 .		
	44	21.84	838	1.81	11724	2 0 .		
	36	26.52	1015	1.58	11820	2 5 .		
	33	29.17	1118	1.43	11830	2 8 .		
	29	33.52	1285	1.25	11256	3 2 .		
	25	38.01	1454	1.1	10931	3 6 .		
	23	41.92	1604	1	10606	4 0 .		
	20	48.01	1833	0.87	9799	4 5 .		
	52	18.41	707	3.55	14800	K 0 8 3 2 1 8 . _ M _ _ _ 4 . 0 C _ _	171	132M
	46	20.67	793	3.28	15100	2 0 .		
	38	25.35	974	2.75	16050	2 5 .		
	34	28.56	1094	2.45	16362	2 8 .		
	29	33.24	1273	2.11	16650	3 2 .		
	26	36.88	1410	1.9	19200	3 6 .		
	24	40.36	1544	1.74	19500	4 0 .		
	21	45.66	1745	1.53	20000	4 5 .		
	19	51.54	1970	1.36	15850	5 0 .		
	15	62.47	2387	1.12	15008	6 3 .		
	13	72.86	2777	0.96	14118	7 1 .		
	12	80.03	3054	0.88	12971	8 0 .		
	21	44.89	1718	2.2	34000	K 0 9 3 1 4 5 . _ M _ _ _ 4 . 0 C _ _	224	132M
	19	49.87	1909	1.98	34000	5 0 .		
	18	54.09	2063	2.04	34000	5 6 .		
	16	60.1	2291	1.84	34000	6 3 .		
	14	70.45	2690	1.4	34000	7 1 .		
	12	77.78	2970	1.27	34000	8 0 .		
	11	84.89	3232	1.3	34000	9 0 .		
	10	93.71	3567	1.18	34000	1 0 0		
	9	106.99	4075	0.93	34000	1 1 2		
	8	120.31	4567	0.83	34000	1 2 5		
	7.4	128.92	4895	0.86	34000	1 4 0		
	18	54.61	2084	3.45	43400	K 1 0 3 1 5 6 . _ M _ _ _ 4 . 0 C _ _	348	132M
	16	60.68	2319	3.1	43400	6 3 .		
	13	71.89	2765	2.6	43400	7 1 .		
	12	82.83	3167	2.27	43383	8 0 .		
	11	86.53	3305	2.17	43383	9 0 .		
	10	99.7	3804	1.89	43362	1 0 0		
	8.6	112.03	4273	1.68	43400	1 1 2		
	8	120.36	4586	1.57	43400	1 2 5		
	7.1	134.85	5135	1.4	43230	1 4 0		
	6.6	144.88	5509	1.3	43150	1 6 0		
	5.8	166.84	6275	1.15	43100	K 1 0 5 1 1 6 0 _ M _ _ _ 4 . 0 C _ _	379	132M
	4.2	231.1	8692	0.83	43100	2 0 0		
	10	100.12	3784	3.25	61700	K 1 2 3 1 1 0 0 _ M _ _ _ 4 . 0 C _ _	482	132M
	8.4	113.79	4321	2.8	61700	1 1 2		
	7.9	121.06	4609	2.62	61693	1 2 5		
	7	137.09	5211	2.36	61683	1 4 0		
	6.6	145.85	5546	2.22	61700	1 6 0		
	5.6	172.15	6481	1.87	61368	K 1 2 5 1 1 6 0 _ M _ _ _ 4 . 0 C _ _	539	132M
	3.6	268.79	10111	1.2	61368	2 0 0		
	4	238.46	8977	1.35	61368	2 5 0		
	3.2	301.94	11357	1.06	61368	2 8 0		
	2.9	331.99	12487	0.97	61368	3 2 0		
	2.5	384.7	14474	0.84	61368	3 6 0		

NOTE
Other output speeds are available using 2 and 8 pole motors - Consult Textron Power Transmission

0205

5.5 kW	N2 R/MIN	i	M2 Nm	Fm	N	Unit Designation	Kg	Motor Size
	Output Speed	Ratio	Output Torque	Service Factor	Overhung Load	Column Entry 1 Through 20 Spaces to be filled when entering order	Weight of base mount unit	
	4 POLE							
	176	8.11	286	1.37	3480	K 0 5 3 2 8 . 0 _ M _ - _ _ 5 . 5 K - -	80	112MA
	125	11.4	403	1.11	3270	1 1 .		
	112	12.78	452	1.03	3140	1 2 .		
	100	14.35	508	0.95	2970	1 4 .		
	78	18.22	646	0.8	2490	1 8 .		
	180	7.96	280	1.99	8000	K 0 6 3 2 8 . 0 _ M _ - _ _ 5 . 5 K - -	88	112MA
	128	11.19	396	1.62	8000	1 1 .		
	114	12.54	445	1.5	6000	1 2 .		
	102	14.08	499	1.39	5990	1 4 .		
	80	17.88	633	1.18	5870	1 8 .		
	71	20.27	719	1.08	5740	2 0 .		
	59	24.18	858	0.95	5460	2 5 .		
	51	27.84	986	0.84	5130	2 8 .		
	168	8.6	299	2.37	8915	K 0 7 3 2 8 . 0 _ M _ - _ _ 5 . 5 A - -	111	132SA
	121	11.91	416	2.37	9444	1 1 .		
	108	13.37	469	2.37	9575	1 2 .		
	98	14.71	515	2.37	9705	1 4 .		
	75	19.21	673	2	9965	1 8 .		
	66	21.84	767	1.82	10027	2 0 .		
	54	26.52	932	1.6	10127	2 5 .		
	49	29.17	1025	1.49	10049	2 8 .		
	43	33.52	1176	1.34	9935	3 2 .		
	38	38.01	1332	1.2	9792	3 6 .		
	34	41.92	1469	1.09	9600	4 0 .		
	30	48.01	1681	0.95	9185	4 5 .		
	27	54.28	1901	0.84	8717	5 0 .		
	166	8.6	301	2.35	8915	K 0 7 3 2 8 . 0 _ M _ - _ _ 5 . 5 K - -	106	112MA
	120	11.91	419	2.35	9444	1 1 .		
	107	13.37	472	2.35	9575	1 2 .		
	97	14.71	519	2.35	9705	1 4 .		
	74	19.21	678	1.99	9965	1 8 .		
	65	21.84	773	1.81	10027	2 0 .		
	54	26.52	938	1.59	10127	2 5 .		
	49	29.17	1033	1.48	10049	2 8 .		
	43	33.52	1184	1.33	9935	3 2 .		
	38	38.01	1341	1.19	9792	3 6 .		
	34	41.92	1479	1.08	9600	4 0 .		
	30	48.01	1693	0.94	9185	4 5 .		
	26	54.28	1914	0.84	8717	5 0 .		
	78	18.41	646	3.56	12711	K 0 8 3 2 1 8 . _ M _ - _ _ 5 . 5 A - -	167	132SA
	70	20.67	723	3.25	12911	2 0 .		
	57	25.35	889	2.74	14131	2 5 .		
	50	28.56	1000	2.53	14477	2 8 .		
	43	33.24	1164	2.28	14722	3 2 .		
	39	36.88	1290	2.08	14227	3 6 .		
	36	40.36	1413	1.9	14227	4 0 .		
	32	45.66	1599	1.68	14227	4 5 .		
	28	51.54	1805	1.48	13715	5 0 .		
	23	62.47	2185	1.23	13387	6 3 .		
	20	72.86	2545	1.05	12914	7 1 .		
	18	80.03	2795	0.96	12524	8 0 .		
	32	44.89	1574	2.4	34000	K 0 9 3 1 4 5 . _ M _ - _ _ 5 . 5 A - -	220	132SA
	29	49.87	1744	2.17	34000	5 0 .		
	27	54.09	1895	2.22	34000	5 6 .		
	24	60.1	2100	2	34000	6 3 .		
	20	70.45	2465	1.53	34000	7 1 .		
	19	77.78	2722	1.39	34000	8 0 .		
	17	84.89	2958	1.42	34000	9 0 .		
	15	93.71	3265	1.29	34000	1 0 0		
	13	106.99	3738	1.01	34000	1 1 2		
	12	120.31	4186	0.9	34000	1 2 5		
	11	128.92	4483	0.94	34000	1 4 0		
	26	54.61	1914	3.76	43400	K 1 0 3 1 5 6 . _ M _ - _ _ 5 . 5 A - -	344	132SA
	24	60.68	2129	3.38	43400	6 3 .		
	20	71.89	2520	2.85	43400	7 1 .		
	17	82.83	2906	2.47	43400	8 0 .		
	17	86.53	3039	2.37	43400	9 0 .		
	14	99.7	3492	2.06	43372	1 0 0		
	13	112.03	3903	1.84	43372	1 1 2		
	12	120.36	4200	1.71	43372	1 2 5		
	11	134.85	4701	1.53	43215	1 4 0		
	10	144.88	5046	1.42	43215	1 6 0		
	8.6	166.84	5730	1.25	43100	K 1 0 5 1 1 6 0 _ M _ - _ _ 5 . 5 A - -	375	132SA
	6.2	231.1	7938	0.91	43100	2 0 0		
	5.5	259.6	8917	0.81	43100	2 5 0		
	8.6	166.84	5770	1.25	43100	K 1 0 5 1 1 6 0 _ M _ - _ _ 5 . 5 K - -	370	112MA
	6.2	231.1	7993	0.9	43100	2 0 0		
	5.5	259.6	8979	0.8	43100	2 5 0		

NOTE
Other output speeds are available using 2 and 8 pole motors - Consult Textron Power Transmission

0205

5.5 kW	N2 R/MIN	i	M2 Nm	Fm	N	Unit Designation	Kg					
	Output Speed	Ratio	Output Torque	Service Factor	Overhung Load	Column Entry 1 Through 20 Spaces to be filled when entering order	Weight of base mount unit	Motor Size				
4 POLE	16	89.89	3124	3.94	61700	K 1 2 3 1 9 0 . _ M _ _ _ _ 5 . 5 A - -	478	132SA				
	14	100.12	3475	3.54	61700	1 0 0						
	13	113.79	3965	3.05	61700	1 1 2						
	12	121.06	4241	2.85	61700	1 2 5						
	11	137.09	4763	2.58	61700	1 4 0						
	10	145.85	5083	2.42	61700	1 6 0						
	4 POLE	8.4	172.15	5927	2.04	61368	K 1 2 5 1 1 6 0 _ M _ _ _ _ 5 . 5 A - -	535	132SA			
		5.4	268.79	9244	1.31	61368	2 0 0					
		6	238.46	8210	1.47	61368	2 5 0					
		4.8	301.94	10384	1.16	61368	2 8 0					
		4.3	331.99	11418	1.06	61368	3 2 0					
		3.7	384.7	13242	0.91	61368	3 6 0					
		3.3	437.38	15054	0.8	61368	4 0 0					
		4 POLE	8.3	172.15	5968	2.03	61368			K 1 2 5 1 1 6 0 _ M _ _ _ _ 5 . 5 K - -	530	112MA
			5.3	268.79	9309	1.3	61368			2 0 0		
6	238.46		8268	1.46	61368	2 5 0						
4.7	301.94		10457	1.16	61368	2 8 0						
4.3	331.99		11498	1.05	61368	3 2 0						
3.7	384.7		13335	0.91	61368	3 6 0						
6 POLE	112	8.6	452	1.57	9530	K 0 7 3 2 8 . 0 _ M _ _ _ _ 5 . 5 C - -	115	132M				
	81	11.91	627	1.57	9920	1 1 .						
	72	13.37	705	1.57	10000	1 2 .						
	65	14.71	775	1.57	10100	1 4 .						
	50	19.21	1012	1.44	10100	1 8 .						
	44	21.84	1153	1.32	9960	2 0 .						
	36	26.52	1396	1.15	9670	2 5 .						
	33	29.17	1538	1.04	9440	2 8 .						
	29	33.52	1767	0.91	9010	3 2 .						
	25	38.01	2000	0.8	8490	3 6 .						
	6 POLE	118	8.13	426	3.16	12021			K 0 8 3 2 8 . 0 _ M _ _ _ _ 5 . 5 C - -	171	132M	
		83	11.52	606	3.16	13014			1 1 .			
		75	12.8	673	3.16	13271			1 2 .			
		67	14.24	752	3.11	13607			1 4 .			
		52	18.41	972	2.58	14157			1 8 .			
		46	20.67	1091	2.38	14392	2 0 .					
		38	25.35	1340	2	15075	2 5 .					
		34	28.56	1505	1.78	15256	2 8 .					
		29	33.24	1750	1.53	15375	3 2 .					
		26	36.88	1939	1.38	19200	3 6 .					
		24	40.36	2123	1.26	19500	4 0 .					
		21	45.66	2400	1.12	20000	4 5 .					
		19	51.54	2709	0.99	12460	5 0 .					
		15	62.47	3282	0.82	11113	6 3 .					
		6 POLE	21	44.89	2362	1.6	34000	K 0 9 3 1 4 5 . _ M _ _ _ _ 5 . 5 C - -	224			132M
	19		49.87	2625	1.44	34000	5 0 .					
	18		54.09	2837	1.48	34000	5 6 .					
	16		60.1	3150	1.34	34000	6 3 .					
	14		70.45	3699	1.02	34000	7 1 .					
	12		77.78	4084	0.93	34000	8 0 .					
11	84.89		4444	0.95	34000	9 0 .						
10	93.71		4905	0.86	34000	1 0 0						
6 POLE	21		45.37	2396	3	43400	K 1 0 3 1 4 5 . _ M _ _ _ _ 5 . 5 C - -	348		132M		
	19		50.41	2654	2.71	43400	5 0 .					
	18		54.61	2865	2.51	43400	5 6 .					
	16		60.68	3189	2.25	43391	6 3 .					
	13		71.89	3802	1.89	43389	7 1 .					
	12		82.83	4355	1.65	43358	8 0 .					
	11		86.53	4545	1.58	43358	9 0 .					
	10	99.7	5230	1.37	43306	1 0 0						
	8.6	112.03	5875	1.22	43400	1 1 2						
	8	120.36	6307	1.14	43400	1 2 5						
	7.1	134.85	7061	1.02	43088	1 4 0						
	6.6	144.88	7575	0.95	43000	1 6 0						
	6 POLE	5.8	166.84	8629	0.83	43100	K 1 0 5 1 1 6 0 _ M _ _ _ _ 5 . 5 C - -		379		132M	
		13	74.62	3914	3.09	61700	K 1 2 3 1 7 1 . _ M _ _ _ _ 5 . 5 C - -					
		12	83.1	4349	2.78	61700	8 0 .					
11		89.89	4697	2.62	61700	9 0 .						
10		100.12	5203	2.36	61700	1 0 0						
8.4		113.79	5941	2.04	61689	1 1 2						
7.9		121.06	6338	1.91	61683	1 2 5						
7		137.09	7166	1.72	61658	1 4 0						
6.6		145.85	7626	1.61	61700	1 6 0						
6 POLE		5.6	172.15	8911	1.36	61368	K 1 2 5 1 1 6 0 _ M _ _ _ _ 5 . 5 C - -	539		132M		
		3.6	268.79	13903	0.87	61368	2 0 0					
		4	238.46	12343	0.98	61368	2 5 0					

NOTE
Other output speeds are available using 2 and 8 pole motors - Consult Textron Power Transmission

0205

7.5 kW	N2 R/MIN	i	M2 Nm	Fm	N	Unit Designation	Kg	Motor Size
	Output Speed	Ratio	Output Torque	Service Factor	Overhung Load	Column Entry <input type="text" value="1"/> Through <input type="text" value="20"/> Spaces to be filled when entering order	Weight of base mount unit	
	4 POLE							
	168	8.6	407	1.74	8295	K 0 7 3 2 8 . 0 _ M _ _ _ 7 . 5 A _ _	115	132M
	121	11.91	565	1.74	8570	1 1 .		
	108	13.37	637	1.74	8610	1 2 .		
	98	14.71	700	1.74	8645	1 4 .		
	75	19.21	915	1.47	8585	1 8 .		
	66	21.84	1043	1.34	8465	2 0 .		
	54	26.52	1267	1.18	8204	2 5 .		
	50	29.17	1394	1.1	7957	2 8 .		
	43	33.52	1598	0.99	7532	3 2 .		
	38	38.01	1810	0.88	7060	3 6 .		
	34	41.92	1996	0.8	6570	4 0 .		
	178	8.13	386	3.49	10798	K 0 8 3 2 8 . 0 _ M _ _ _ 7 . 5 A _ _	171	132M
	125	11.52	549	3.49	11458	1 1 .		
	113	12.8	611	3.32	11738	1 2 .		
	101	14.24	676	3.15	11938	1 4 .		
	78	18.41	878	2.62	12477	1 8 .		
	70	20.67	982	2.39	12677	2 0 .		
	57	25.35	1208	2.02	13640	2 5 .		
	51	28.56	1360	1.86	13913	2 8 .		
	43	33.24	1582	1.67	14086	3 2 .		
	39	36.88	1753	1.53	13450	3 6 .		
	36	40.36	1920	1.4	13450	4 0 .		
	32	45.66	2173	1.23	13450	4 5 .		
	28	51.54	2453	1.09	10600	5 0 .		
	23	62.47	2970	0.9	9630	6 3 .		
	32	44.89	2138	1.77	34000	K 0 9 3 1 4 5 . _ M _ _ _ 7 . 5 A _ _	224	132M
	29	49.87	2370	1.59	34000	5 0 .		
	27	54.09	2575	1.63	34000	5 6 .		
	24	60.1	2854	1.47	34000	6 3 .		
	21	70.45	3350	1.13	34000	7 1 .		
	19	77.78	3699	1.02	34000	8 0 .		
	17	84.89	4020	1.05	34000	9 0 .		
	15	93.71	4437	0.95	34000	1 0 0		
	32	45.37	2164	3.32	35600	K 1 0 3 1 4 5 . _ M _ _ _ 7 . 5 A _ _	348	132M
	29	50.41	2404	2.99	35600	5 0 .		
	26	54.61	2601	2.76	43400	5 6 .		
	24	60.68	2893	2.48	43400	6 3 .		
	20	71.89	3424	2.1	43400	7 1 .		
	17	82.83	3949	1.82	43400	8 0 .		
	17	86.53	4130	1.74	43400	9 0 .		
	14	99.7	4746	1.51	43350	1 0 0		
	13	112.03	5305	1.36	43350	1 1 2		
	12	120.36	5707	1.26	43350	1 2 5		
	11	134.85	6388	1.13	43100	1 4 0		
	10	144.88	6858	1.05	43100	1 6 0		
	8.7	166.84	7787	0.92	43100	K 1 0 5 1 1 6 0 _ M _ _ _ 7 . 5 A _ _	379	132M
	19	74.62	3543	3.41	61700	K 1 2 3 1 7 1 . _ M _ _ _ 7 . 5 A _ _	482	132M
	17	83.1	3942	3.07	61700	8 0 .		
	16	89.89	4246	2.9	61700	9 0 .		
	14	100.12	4722	2.6	61700	1 0 0		
	13	113.79	5388	2.25	61700	1 1 2		
	12	121.06	5763	2.1	61700	1 2 5		
	11	137.09	6473	1.9	61700	1 4 0		
	10	145.85	6908	1.78	61700	1 6 0		
	8.4	172.15	8054	1.5	61368	K 1 2 5 1 1 6 0 _ M _ _ _ 7 . 5 A _ _	539	132M
	5.4	268.79	12563	0.96	61368	2 0 0		
	6.1	238.46	11157	1.08	61368	2 5 0		
	4.8	301.94	14112	0.86	61368	2 8 0		

NOTE
Other output speeds are available using 2 and 8 pole motors - Consult Textron Power Transmission

0205

7.5 kW	N2 R/MIN	i	M2 Nm	Fm	N	Unit Designation	Kg	Motor Size
	Output Speed	Ratio	Output Torque	Service Factor	Overhung Load	Column Entry 1 Through 20 Spaces to be filled when entering order	Weight of base mount unit	
6 POLE	118	8.13	581	2.32	11650	K 0 8 3 2 8 . 0 _ M _ _ _ 7 . 5 C _ _	205	160MA
	83	11.52	827	2.32	12500	1 1 .		
	75	12.8	918	2.32	12700	1 2 .		
	67	14.24	1026	2.28	12950	1 4 .		
	52	18.41	1325	1.89	13300	1 8 .		
	46	20.67	1488	1.75	13450	2 0 .		
	38	25.35	1827	1.47	13775	2 5 .		
	34	28.56	2053	1.31	13781	2 8 .		
	29	33.24	2387	1.12	13675	3 2 .		
	26	36.88	2644	1.01	19200	3 6 .		
	24	40.36	2896	0.93	19500	4 0 .		
	21	45.66	3273	0.82	20000	4 5 .		
	64	14.94	1071	3.76	34000	K 0 9 3 1 1 6 . _ M _ _ _ 7 . 5 C _ _	258	160MA
	54	17.93	1285	2.89	34000	1 8 .		
	48	20.03	1435	2.63	34000	2 0 .		
	44	21.61	1547	2.72	34000	2 2 .		
	40	24.14	1725	2.44	34000	2 5 .		
	35	27.78	1996	1.89	34000	2 8 .		
	30	31.67	2268	1.67	34000	3 2 .		
	29	33.47	2392	1.76	34000	3 6 .		
	25	38.16	2721	1.55	34000	4 0 .		
	21	44.89	3221	1.17	34000	4 5 .		
	19	49.87	3579	1.06	34000	5 0 .		
	18	54.09	3869	1.09	34000	5 6 .		
	16	60.1	4295	0.98	34000	6 3 .		
	29	33.1	2386	3.01	35600	K 1 0 3 1 3 2 . _ M _ _ _ 7 . 5 C _ _	382	160MA
	27	35.19	2531	2.84	35600	3 6 .		
	24	39.84	2868	2.51	35600	4 0 .		
	21	45.37	3268	2.2	43400	4 5 .		
	19	50.41	3619	1.99	43400	5 0 .		
	18	54.61	3907	1.84	43400	5 6 .		
	16	60.68	4348	1.65	43380	6 3 .		
	13	71.89	5185	1.39	43375	7 1 .		
	12	82.83	5938	1.21	43325	8 0 .		
	11	86.53	6198	1.16	43325	9 0 .		
	10	99.7	7132	1.01	43231	1 0 0		
	8.6	112.03	8012	0.9	43400	1 1 2		
	8	120.36	8600	0.84	43400	1 2 5		
	18	52.76	3781	3.2	61700	K 1 2 3 1 5 0 . _ M _ _ _ 7 . 5 C _ _	517	160MA
	17	56.39	4028	3.05	61700	5 6 .		
	15	63.57	4544	2.71	61700	6 3 .		
	13	74.62	5338	2.27	61700	7 1 .		
	12	83.1	5931	2.04	61700	8 0 .		
	11	89.89	6406	1.92	61700	9 0 .		
	10	100.12	7096	1.73	61700	1 0 0		
	8.4	113.79	8102	1.49	61675	1 1 2		
	7.9	121.06	8642	1.4	61670	1 2 5		
	7	137.09	9772	1.26	61625	1 4 0		
6.6	145.85	10400	1.18	61700	1 6 0			

NOTE
Other output speeds are available using 2 and 8 pole motors - Consult Textron Power Transmission

0205

9.2 kW	N2 R/MIN	i	M2 Nm	Fm	N	Unit Designation	Kg	
	Output Speed	Ratio	Output Torque	Service Factor	Overhung Load	Column Entry <input type="text" value="1"/> Through <input type="text" value="20"/> Spaces to be filled when entering order	Weight of base mount unit	Motor Size
4 POLE	168	8.6	501	1.41	7768	K 0 7 3 2 8 . 0 _ M _ - _ _ 9 . 2 K - - 1 1 . 1 2 . 1 4 . 1 8 . 2 0 . 2 5 . 2 8 . 3 2 . K 1 2 5 1 1 6 0 _ M _ - _ _ 9 . 2 K - - 2 5 0	141	132MA
	121	11.91	696	1.41	7826			
	108	13.37	784	1.41	7789			
	98	14.71	862	1.41	7744			
	75	19.21	1126	1.2	7412			
	66	21.84	1284	1.09	7136			
	54	26.52	1559	0.96	6570			
	49	29.17	1715	0.89	6180			
	43	33.52	1967	0.8	5490			
	8.4	172.15	9914	1.22	61368			
	6	238.46	13734	0.88	61368			

NOTE
Other output speeds are available using 2 and 8 pole motors - Consult Textron Power Transmission

0205

11.0 kW	N2 R/MIN	i	M2 Nm	Fm	N	Unit Designation	Kg	Motor Size
	Output Speed	Ratio	Output Torque	Service Factor	Overhung Load	Column Entry <input type="text" value="1"/> Through <input type="text" value="20"/> Spaces to be filled when entering order	Weight of base mount unit	
	4 POLE							
	168	8.6	599	1.18	7210	K 0 7 3 2 8 . 0 _ M _ _ _ _ 1 1 . K - -	151	132MB
	121	11.91	832	1.18	7040	1 1 .		
	108	13.37	938	1.18	6920	1 2 .		
	98	14.71	1031	1.18	6790	1 4 .		
	75	19.21	1347	1	6170	1 8 .		
	66	21.84	1535	0.91	5730	2 0 .		
	178	8.13	564	2.39	10612	K 0 8 3 2 8 . 0 _ M _ _ _ _ 1 1 . A - -	205	160MA
	126	11.52	803	2.39	11197	1 1 .		
	113	12.8	893	2.27	11440	1 2 .		
	102	14.24	988	2.15	11640	1 4 .		
	79	18.41	1284	1.79	12068	1 8 .		
	70	20.67	1436	1.64	12268	2 0 .		
	57	25.35	1765	1.38	12781	2 5 .		
	51	28.56	1987	1.27	12927	2 8 .		
	44	33.24	2313	1.15	12972	3 2 .		
	39	36.88	2563	1.05	12088	3 6 .		
	36	40.36	2807	0.95	12088	4 0 .		
	32	45.66	3176	0.84	12088	4 5 .		
	131	11.06	768	3.89	34000	K 0 9 3 1 1 1 . _ M _ _ _ _ 1 1 . A - -	258	160MA
	117	12.4	860	3.64	34000	1 2 .		
	109	13.33	925	3.89	34000	1 4 .		
	97	14.94	1036	3.64	34000	1 6 .		
	81	17.93	1250	2.78	34000	1 8 .		
	72	20.03	1393	2.55	34000	2 0 .		
	67	21.61	1501	2.76	34000	2 2 .		
	60	24.14	1677	2.51	34000	2 5 .		
	52	27.78	1928	1.95	34000	2 8 .		
	46	31.67	2211	1.71	34000	3 2 .		
	43	33.47	2327	1.81	34000	3 6 .		
	38	38.16	2646	1.59	34000	4 0 .		
	32	44.89	3126	1.21	34000	4 5 .		
	29	49.87	3465	1.09	34000	5 0 .		
	27	54.09	3765	1.12	34000	5 6 .		
	24	60.1	4172	1.01	34000	6 3 .		
	44	33.1	2312	3.11	35604	K 1 0 3 1 3 2 . _ M _ _ _ _ 1 1 . A - -	382	160MA
	41	35.19	2456	2.93	35604	3 6 .		
	36	39.84	2775	2.59	35605	4 0 .		
	32	45.37	3163	2.27	35584	4 5 .		
	29	50.41	3515	2.05	35575	5 0 .		
	27	54.61	3802	1.89	43400	5 6 .		
	24	60.68	4229	1.7	43400	6 3 .		
	20	71.89	5005	1.44	43400	7 1 .		
	18	82.83	5772	1.25	43400	8 0 .		
	17	86.53	6037	1.19	43400	9 0 .		
	15	99.7	6937	1.04	43311	1 0 0		
	13	112.03	7753	0.93	43311	1 1 2		
	12	120.36	8342	0.86	43311	1 2 5		
	31	46.81	3262	3.71	61800	K 1 2 3 1 4 5 . _ M _ _ _ _ 1 1 . A - -	517	160MA
	27	52.76	3676	3.29	61800	5 0 .		
	26	56.39	3910	3.15	61832	5 6 .		
	23	63.57	4407	2.79	61832	6 3 .		
	19	74.62	5178	2.34	61186	7 1 .		
	17	83.1	5761	2.1	61186	8 0 .		
	16	89.89	6206	1.98	61700	9 0 .		
	14	100.12	6903	1.78	61700	1 0 0		
	13	113.79	7875	1.54	61700	1 1 2		
	12	121.06	8424	1.44	61700	1 2 5		
	11	137.09	9461	1.3	61700	1 4 0		
	10	145.85	10097	1.22	61700	1 6 0		
	8.4	172.15	11854	1.02	61368	K 1 2 5 1 1 6 0 _ M _ _ _ _ 1 1 . K - -	575	132MB

NOTE
Other output speeds are available using 2 and 8 pole motors - Consult Textron Power Transmission

0205

11.0 kW	N2 R/MIN	i	M2 Nm	Fm	N	Unit Designation	Kg	Motor Size
	Output Speed	Ratio	Output Torque	Service Factor	Overhung Load	Column Entry <input type="text" value="1"/> Through <input type="text" value="20"/> Spaces to be filled when entering order	Weight of base mount unit	
	6 POLE							
	119	8.13	849	1.59	11000	K 0 8 3 2 8 . 0 _ M _ _ _ _ 1 1 . C - -	219	160L
	84	11.52	1207	1.59	11600	1 1 .		
	75	12.8	1339	1.59	11700	1 2 .		
	68	14.24	1497	1.56	11800	1 4 .		
	52	18.41	1934	1.3	11800	1 8 .		
	47	20.67	2171	1.2	11800	2 0 .		
	38	25.35	2666	1.01	11500	2 5 .		
	34	28.56	2995	0.89	11200	2 8 .		
	120	8.03	842	3.45	34000	K 0 9 3 1 8 . 0 _ M _ _ _ _ 1 1 . C - -	272	160L
	100	9.68	1013	3.45	34000	1 0 .		
	87	11.06	1158	2.8	34000	1 1 .		
	78	12.4	1299	2.58	34000	1 2 .		
	72	13.33	1394	2.8	34000	1 4 .		
	65	14.94	1563	2.58	34000	1 6 .		
	54	17.93	1875	1.98	34000	1 8 .		
	48	20.03	2094	1.8	34000	2 0 .		
	45	21.61	2258	1.86	34000	2 2 .		
	40	24.14	2517	1.67	34000	2 5 .		
	35	27.78	2912	1.3	34000	2 8 .		
	30	31.67	3309	1.14	34000	3 2 .		
	29	33.47	3490	1.21	34000	3 6 .		
	25	38.16	3971	1.06	34000	4 0 .		
	21	44.89	4700	0.8	34000	4 5 .		
	43	22.35	2341	3.07	35600	K 1 0 3 1 2 2 . _ M _ _ _ _ 1 1 . C - -	396	160L
	40	24.13	2529	2.84	35600	2 5 .		
	33	29.24	3073	2.34	35600	2 8 .		
	29	33.1	3481	2.07	35553	3 2 .		
	27	35.19	3693	1.95	35553	3 6 .		
	24	39.84	4185	1.72	35553	4 0 .		
	21	45.37	4768	1.51	43400	4 5 .		
	19	50.41	5280	1.36	43400	5 0 .		
	18	54.61	5701	1.26	43400	5 6 .		
	16	60.68	6345	1.13	43361	6 3 .		
	13	71.89	7565	0.95	43351	7 1 .		
	12	82.83	8665	0.83	43266	8 0 .		
	28	34.93	3657	3.36	61700	K 1 2 3 1 3 6 . _ M _ _ _ _ 1 1 . C - -	531	160L
	24	39.55	4141	2.97	61700	4 0 .		
	21	46.81	4904	2.47	61700	4 5 .		
	18	52.76	5517	2.19	61672	5 0 .		
	17	56.39	5877	2.09	61664	5 6 .		
	15	63.57	6630	1.86	61664	6 3 .		
	13	74.62	7788	1.55	61700	7 1 .		
	12	83.1	8654	1.4	61700	8 0 .		
	11	89.89	9347	1.32	61700	9 0 .		
	10	100.12	10353	1.19	61700	1 0 0		
	8.5	113.79	11822	1.02	61651	1 1 2		
	8	121.06	12610	0.96	61648	1 2 5		
	7	137.09	14258	0.86	61566	1 4 0		
	6.6	145.85	15174	0.81	61700	1 6 0		

NOTE
Other output speeds are available using 2 and 8 pole motors - Consult Textron Power Transmission

0205

15.0 kW	N2 R/MIN	i	M2 Nm	Fm	N	Unit Designation	Kg	Motor Size
	Output Speed	Ratio	Output Torque	Service Factor	Overhung Load	Column Entry <input type="text" value="1"/> Through <input type="text" value="20"/> Spaces to be filled when entering order	Weight of base mount unit	
	4 POLE							
	179	8.13	767	1.76	10400	K 0 8 3 2 8 . 0 _ M _ _ _ 1 5 . A _ _	219	160L
	126	11.52	1091	1.76	10900	1 1 .		
	114	12.8	1213	1.67	11100	1 2 .		
	102	14.24	1343	1.59	11300	1 4 .		
	79	18.41	1745	1.32	11600	1 8 .		
	70	20.67	1951	1.2	11800	2 0 .		
	57	25.35	2399	1.02	11800	2 5 .		
	51	28.56	2701	0.94	11800	2 8 .		
	44	33.24	3143	0.84	11700	3 2 .		
	181	8.03	757	3.39	34000	K 0 9 3 1 8 . 0 _ M _ _ _ 1 5 . A _ _	272	160L
	150	9.68	914	3.39	34000	1 0 .		
	132	11.06	1044	2.86	34000	1 1 .		
	117	12.4	1169	2.68	34000	1 2 .		
	109	13.33	1257	2.86	34000	1 4 .		
	97	14.94	1408	2.68	34000	1 6 .		
	81	17.93	1700	2.05	34000	1 8 .		
	73	20.03	1893	1.88	34000	2 0 .		
	67	21.61	2040	2.03	34000	2 2 .		
	60	24.14	2280	1.85	34000	2 5 .		
	52	27.78	2621	1.44	34000	2 8 .		
	46	31.67	3005	1.26	34000	3 2 .		
	43	33.47	3162	1.33	34000	3 6 .		
	38	38.16	3596	1.17	34000	4 0 .		
	32	44.89	4248	0.89	34000	4 5 .		
	29	49.87	4708	0.8	34000	5 0 .		
	27	54.09	5116	0.82	34000	5 6 .		
	73	20.05	1901	3.77	35600	K 1 0 3 1 2 0 . _ M _ _ _ 1 5 . A _ _	396	160L
	65	22.35	2115	3.4	35600	2 2 .		
	60	24.13	2281	3.15	35600	2 5 .		
	50	29.24	2777	2.59	35600	2 8 .		
	44	33.1	3142	2.29	35588	3 2 .		
	41	35.19	3337	2.15	35588	3 6 .		
	37	39.84	3771	1.91	35583	4 0 .		
	32	45.37	4299	1.67	35566	4 5 .		
	29	50.41	4776	1.51	35548	5 0 .		
	27	54.61	5167	1.39	43400	5 6 .		
	24	60.68	5747	1.25	43400	6 3 .		
	20	71.89	6802	1.06	43400	7 1 .		
	18	82.83	7845	0.92	43400	8 0 .		
	17	86.53	8204	0.88	43400	9 0 .		
	44	32.83	3118	3.88	61700	K 1 2 3 1 3 2 . _ M _ _ _ 1 5 . A _ _	531	160L
	42	34.93	3301	3.73	61469	3 6 .		
	37	39.55	3744	3.28	61469	4 0 .		
	31	46.81	4433	2.73	61400	4 5 .		
	28	52.76	4996	2.42	61400	5 0 .		
	26	56.39	5314	2.31	61304	5 6 .		
	23	63.57	5989	2.05	61304	6 3 .		
	19	74.62	7037	1.72	60600	7 1 .		
	18	83.1	7830	1.55	60600	8 0 .		
	16	89.89	8434	1.46	61700	9 0 .		
	15	100.12	9380	1.31	61700	1 0 0		
	13	113.79	10702	1.13	61700	1 1 2		
	12	121.06	11447	1.06	61700	1 2 5		
	11	137.09	12857	0.96	61700	1 4 0		
	10	145.85	13721	0.9	61700	1 6 0		

NOTE
Other output speeds are available using 2 and 8 pole motors - Consult Textron Power Transmission

0205

15.0 kW	N2 R/MIN	i	M2 Nm	Fm	N	Unit Designation	Kg	Motor Size		
	Output Speed	Ratio	Output Torque	Service Factor	Overhung Load	Column Entry 1 Through 20 Spaces to be filled when entering order	Weight of base mount unit			
6 POLE	121	8.03	1142	2.55	34000	K 0 9 3 1 8 . 0 _ M _ _ _ 1 5 . C _ _	371	D180L		
	100	9.68	1374	2.55	34000	1 0 .				
	88	11.06	1571	2.06	34000	1 1 .				
	78	12.4	1763	1.9	34000	1 2 .				
	73	13.33	1892	2.06	34000	1 4 .				
	65	14.94	2121	1.9	34000	1 6 .				
	54	17.93	2544	1.46	34000	1 8 .				
	48	20.03	2840	1.33	34000	2 0 .				
	45	21.61	3063	1.37	34000	2 2 .				
	40	24.14	3415	1.23	34000	2 5 .				
	35	27.78	3951	0.96	34000	2 8 .				
	31	31.67	4489	0.84	34000	3 2 .				
	29	33.47	4734	0.89	34000	3 6 .				
	70	13.89	1974	3.49	35600	K 1 0 3 1 1 4 . _ M _ _ _ 1 5 . C _ _			495	D180L
	64	15.11	2147	3.35	35600	1 6 .				
	52	18.57	2648	2.71	35600	1 8 .				
	48	20.05	2853	2.52	35600	2 0 .				
	43	22.35	3176	2.26	35536	2 2 .				
	40	24.13	3432	2.09	35536	2 5 .				
	33	29.24	4169	1.72	35536	2 8 .				
	29	33.1	4722	1.52	35500	3 2 .				
	28	35.19	5011	1.43	35500	3 6 .				
	24	39.84	5677	1.27	35500	4 0 .				
	21	45.37	6468	1.11	43400	4 5 .				
	19	50.41	7163	1	43400	5 0 .				
	18	54.61	7734	0.93	43400	5 6 .				
	16	60.68	8607	0.84	43338	6 3 .				
	33	28.99	4129	2.93	61700	K 1 2 3 1 2 8 . _ M _ _ _ 1 5 . C _ _	629	D180L		
	30	32.83	4677	2.59	61700	3 2 .				
	28	34.93	4961	2.48	61672	3 6 .				
	25	39.55	5618	2.19	61672	4 0 .				
	21	46.81	6652	1.82	61664	4 5 .				
	18	52.76	7484	1.62	61640	5 0 .				
17	56.39	7973	1.54	61623	5 6 .					
15	63.57	8994	1.37	61623	6 3 .					
13	74.62	10566	1.15	61700	7 1 .					
12	83.1	11740	1.03	61700	8 0 .					
11	89.89	12680	0.97	61700	9 0 .					
10	100.12	14045	0.88	61700	1 0 0					

NOTE
Other output speeds are available using 2 and 8 pole motors - Consult Textron Power Transmission

0205

18.5 kW	N2 R/MIN	i	M2 Nm	Fm	N	Unit Designation	Kg					
	Output Speed	Ratio	Output Torque	Service Factor	Overhung Load	Column Entry <input type="text" value="1"/> Through <input type="text" value="20"/> Spaces to be filled when entering order	Weight of base mount unit	Motor Size				
4 POLE	183	8.03	925	2.78	34000	K 0 9 3 1 8 . 0 _ M _ _ _ 1 8 . A _ _	357	D180M				
	152	9.68	1115	2.78	34000	1 0 .						
	133	11.06	1274	2.35	34000	1 1 .						
	119	12.4	1427	2.19	34000	1 2 .						
	110	13.33	1534	2.35	34000	1 4 .						
	98	14.94	1719	2.19	34000	1 6 .						
	82	17.93	2075	1.68	34000	1 8 .						
	73	20.03	2311	1.54	34000	2 0 .						
	68	21.61	2491	1.67	34000	2 2 .						
	61	24.14	2783	1.51	34000	2 5 .						
	53	27.78	3199	1.18	34000	2 8 .						
	46	31.67	3669	1.03	34000	3 2 .						
	44	33.47	3860	1.09	34000	3 6 .						
	39	38.16	4390	0.96	34000	4 0 .						
	79	18.57	2151	3.27	35600	K 1 0 3 1 1 8 . _ M _ _ _ 1 8 . A _ _			481	D180M		
	73	20.05	2320	3.09	35588	2 0 .						
	66	22.35	2582	2.78	35588	2 2 .						
	61	24.13	2785	2.58	35588	2 5 .						
	50	29.24	3390	2.12	35588	2 8 .						
	44	33.1	3836	1.87	35574	3 2 .						
	42	35.19	4074	1.76	35574	3 6 .						
	37	39.84	4603	1.56	35563	4 0 .						
	32	45.37	5248	1.37	35551	4 5 .						
	29	50.41	5831	1.23	35524	5 0 .						
	27	54.61	6307	1.14	43400	5 6 .						
	24	60.68	7016	1.02	43400	6 3 .						
	20	71.89	8304	0.87	43400	7 1 .						
	45	32.83	3806	3.18	61507	K 1 2 3 1 3 2 . _ M _ _ _ 1 8 . A _ _					615	D180M
	42	34.93	4029	3.05	61201	3 6 .						
	37	39.55	4571	2.69	61201	4 0 .						
	31	46.81	5411	2.24	61050	4 5 .						
	28	52.76	6099	1.98	61050	5 0 .						
	26	56.39	6487	1.9	60842	5 6 .						
	23	63.57	7311	1.68	60842	6 3 .						
	20	74.62	8591	1.41	60086	7 1 .						
	18	83.1	9558	1.27	60086	8 0 .						
16	89.89	10296	1.19	61700	9 0 .							
15	100.12	11451	1.07	61700	1 0 0							
13	113.79	13065	0.93	61700	1 1 2							
12	121.06	13974	0.87	61700	1 2 5							
6 POLE	121	8.03	1402	2.08	34000	K 0 9 3 1 8 . 0 _ M _ _ _ 1 8 . C _ _	426	D200L				
	101	9.68	1686	2.08	34000	1 0 .						
	88	11.06	1928	1.68	34000	1 1 .						
	79	12.4	2163	1.55	34000	1 2 .						
	73	13.33	2321	1.68	34000	1 4 .						
	65	14.94	2603	1.55	34000	1 6 .						
	54	17.93	3122	1.19	34000	1 8 .						
	49	20.03	3485	1.08	34000	2 0 .						
	45	21.61	3759	1.12	34000	2 2 .						
	40	24.14	4190	1	34000	2 5 .						
	118	8.26	1441	2.84	35600	K 1 0 3 1 8 . 0 _ M _ _ _ 1 8 . C _ _			550	D200L		
	98	9.95	1730	2.84	35600	1 0 .						
	84	11.54	2014	2.84	35600	1 1 .						
	78	12.55	2194	2.84	35600	1 2 .						
	70	13.89	2422	2.84	35530	1 4 .						
	65	15.11	2635	2.73	35530	1 6 .						
	53	18.57	3249	2.21	35530	1 8 .						
	49	20.05	3501	2.05	35530	2 0 .						
	44	22.35	3897	1.84	35481	2 2 .						
	40	24.13	4211	1.71	35481	2 5 .						
	33	29.24	5115	1.41	35481	2 8 .						
	29	33.1	5795	1.24	35453	3 2 .						
	28	35.19	6148	1.17	35453	3 6 .						
	24	39.84	6966	1.03	35453	4 0 .						
	21	45.37	7937	0.91	43400	4 5 .						
	19	50.41	8789	0.82	43400	5 0 .						
	115	8.51	1484	3.41	61700	K 1 2 3 1 8 . 0 _ M _ _ _ 1 8 . C _ _	685	D200L				
	95	10.26	1783	3.41	61700	1 0 .						
	83	11.8	2059	3.41	61700	1 1 .						
	75	12.96	2264	3.41	61700	1 2 .						
	69	14.21	2475	3.41	61700	1 4 .						
	62	15.61	2722	3.41	61700	1 6 .						
	54	18.2	3167	3.41	61700	1 8 .						
	48	20.17	3519	3.41	61700	2 0 .						
	44	21.93	3823	3.22	61700	2 2 .						
	40	24.29	4235	2.9	61700	2 5 .						
34	28.99	5066	2.39	61673	2 8 .							
30	32.83	5739	2.11	61673	3 2 .							
28	34.93	6088	2.02	61648	3 6 .							
25	39.55	6893	1.78	61648	4 0 .							
21	46.81	8163	1.48	61633	4 5 .							
18	52.76	9183	1.32	61612	5 0 .							
17	56.39	9783	1.26	61588	5 6 .							
15	63.57	11036	1.11	61588	6 3 .							
13	74.62	12965	0.93	61700	7 1 .							
12	83.1	14405	0.84	61700	8 0 .							

NOTE
Other output speeds are available using 2 and 8 pole motors - Consult Textron Power Transmission

0205

22.0 kW	N2 R/MIN	i	M2 Nm	Fm	N	Unit Designation	Kg	Motor Size				
	Output Speed	Ratio	Output Torque	Service Factor	Overhung Load	Column Entry <input type="text" value="1"/> Through <input type="text" value="20"/> Spaces to be filled when entering order	Weight of base mount unit					
4 POLE	183	8.03	1100	2.34	34000	K 0 9 3 1 8 . 0 _ M _ _ _ 2 2 . A _ _	371	D180L				
	152	9.68	1326	2.34	34000	1 0 .						
	133	11.06	1516	1.97	34000	1 1 .						
	119	12.4	1698	1.84	34000	1 2 .						
	110	13.33	1825	1.97	34000	1 4 .						
	98	14.94	2045	1.84	34000	1 6 .						
	82	17.93	2467	1.41	34000	1 8 .						
	73	20.03	2749	1.29	34000	2 0 .						
	68	21.61	2962	1.4	34000	2 2 .						
	61	24.14	3310	1.27	34000	2 5 .						
	53	27.78	3805	0.99	34000	2 8 .						
	46	31.67	4363	0.87	34000	3 2 .						
	44	33.47	4590	0.92	34000	3 6 .						
	178	8.26	1134	3.6	35600	K 1 0 3 1 8 . 0 _ M _ _ _ 2 2 . A _ _			495	D180L		
	148	9.95	1365	3.6	35600						1 0 .	
	127	11.54	1590	3.6	35600						1 1 .	
	117	12.55	1727	3.57	35600						1 2 .	
	106	13.89	1909	3.6	35600						1 4 .	
	97	15.11	2077	3.46	35586						1 6 .	
	79	18.57	2559	2.75	35586						1 8 .	
	73	20.05	2759	2.59	35576						2 0 .	
	66	22.35	3071	2.34	35576						2 2 .	
	61	24.13	3312	2.17	35576						2 5 .	
	50	29.24	4031	1.78	35576						2 8 .	
	44	33.1	4562	1.58	35560						3 2 .	
	42	35.19	4845	1.48	35560						3 6 .	
	32	45.37	6241	1.15	35535						4 5 .	
	29	50.41	6934	1.04	35500						5 0 .	
27	54.61	7501	0.96	43400	5 6 .							
24	60.68	8343	0.86	43400	6 3 .							
61	24.29	3340	3.68	61700	K 1 2 3 1 2 5 . _ M _ _ _ 2 2 . A _ _		629	D180L				
51	28.99	3996	3.03	61700							2 8 .	
45	32.83	4527	2.67	61315							3 2 .	
42	34.93	4792	2.57	60932							3 6 .	
37	39.55	5436	2.26	60932							4 0 .	
31	46.81	6435	1.88	60700							4 5 .	
28	52.76	7253	1.67	60700							5 0 .	
26	56.39	7714	1.59	60380							5 6 .	
23	63.57	8694	1.41	60380							6 3 .	
20	74.62	10217	1.18	59573							7 1 .	
18	83.1	11367	1.06	59573							8 0 .	
16	89.89	12243	1	61700		9 0 .						
15	100.12	13618	0.9	61700		1 0 0						
6 POLE	121	8.03	1667	1.75		34000			K 0 9 3 1 8 . 0 _ M _ _ _ 2 2 . C _ _	426	D200L	
	101	9.68	2005	1.75		34000						1 0 .
	88	11.06	2293	1.41	34000	1 1 .						
	79	12.4	2573	1.3	34000	1 2 .						
	73	13.33	2760	1.41	34000	1 4 .						
	65	14.94	3095	1.3	34000	1 6 .						
	54	17.93	3713	1	34000	1 8 .						
	49	20.03	4145	0.91	34000	2 0 .						
	45	21.61	4470	0.94	34000	2 2 .						
	40	24.14	4983	0.84	34000	2 5 .						
	118	8.26	1714	2.39	35508	K 1 0 3 1 8 . 0 _ M _ _ _ 2 2 . C _ _	550	D200L				
	98	9.95	2057	2.39	35508							1 0 .
	84	11.54	2396	2.39	35508							1 1 .
	78	12.55	2609	2.39	35508							1 2 .
	70	13.89	2881	2.39	35460							1 4 .
	65	15.11	3133	2.29	35460				1 6 .			
	53	18.57	3864	1.86	35460				1 8 .			
	49	20.05	4164	1.73	35460				2 0 .			
	44	22.35	4635	1.55	35426				2 2 .			
	40	24.13	5007	1.44	35426				2 5 .			
	33	29.24	6083	1.18	35426				2 8 .			
	29	33.1	6891	1.04	35406				3 2 .			
	28	35.19	7312	0.98	35406				3 6 .			
	115	8.51	1765	2.87	61700	K 1 2 3 1 8 . 0 _ M _ _ _ 2 2 . C _ _	685	D200L				
	95	10.26	2120	2.87	61700				1 0 .			
	83	11.8	2448	2.87	61700				1 1 .			
	75	12.96	2692	2.87	61700				1 2 .			
	69	14.21	2944	2.87	61700				1 4 .			
62	15.61	3237	2.87	61690	1 6 .							
54	18.2	3767	2.87	61680	1 8 .							
48	20.17	4185	2.87	61671	2 0 .							
44	21.93	4546	2.71	61671	2 2 .							
40	24.29	5036	2.44	61671	2 5 .							
34	28.99	6025	2.01	61647	2 8 .							
30	32.83	6825	1.77	61647	3 2 .							
28	34.93	7240	1.7	61625	3 6 .							
25	39.55	8198	1.5	61625	4 0 .							
21	46.81	9707	1.25	61602	4 5 .							
18	52.76	10921	1.11	61584	5 0 .							
17	56.39	11634	1.06	61552	5 6 .							
15	63.57	13124	0.94	61552	6 3 .							

NOTE
Other output speeds are available using 2 and 8 pole motors - Consult Textron Power Transmission

0205

30.0 kW	N2 R/MIN	i	M2 Nm	Fm	N	Unit Designation	Kg	Motor Size		
	Output Speed	Ratio	Output Torque	Service Factor	Overhung Load	Column Entry <input type="text" value="1"/> Through <input type="text" value="20"/> Spaces to be filled when entering order	Weight of base mount unit			
4 POLE	183	8.03	1500	1.71	34000	K 0 9 3 1 8 . 0 _ M _ _ _ 3 0 . A _ _	426	D200L		
	152	9.68	1809	1.71	34000	1 0 .				
	133	11.06	2067	1.45	34000	1 1 .				
	119	12.4	2315	1.35	34000	1 2 .				
	110	13.33	2489	1.45	34000	1 4 .				
	98	14.94	2789	1.35	34000	1 6 .				
	82	17.93	3365	1.03	34000	1 8 .				
	73	20.03	3749	0.95	34000	2 0 .				
	68	21.61	4039	1.03	34000	2 2 .				
	61	24.14	4513	0.93	34000	2 5 .				
	178	8.26	1547	2.64	35565	K 1 0 3 1 8 . 0 _ M _ _ _ 3 0 . A _ _			550	D200L
	148	9.95	1861	2.64	35565	1 0 .				
	127	11.54	2168	2.64	35565	1 1 .				
	117	12.55	2355	2.62	35565	1 2 .				
	106	13.89	2603	2.64	35565	1 4 .				
	97	15.11	2833	2.54	35556	1 6 .				
	79	18.57	3489	2.02	35556	1 8 .				
	73	20.05	3763	1.9	35550	2 0 .				
	66	22.35	4188	1.72	35550	2 2 .				
	61	24.13	4517	1.59	35550	2 5 .				
	50	29.24	5497	1.31	35550	2 8 .				
	44	33.1	6221	1.16	35528	3 2 .				
	42	35.19	6607	1.09	35528	3 6 .				
	37	39.84	7465	0.96	35500	4 0 .				
	32	45.37	8510	0.84	35500	4 5 .				
	173	8.51	1596	3.17	61700	K 1 2 3 1 8 . 0 _ M _ _ _ 3 0 . A _ _	685	D200L		
	143	10.26	1918	3.17	61700	1 0 .				
	125	11.8	2214	3.17	61700	1 1 .				
	113	12.96	2435	3.17	61700	1 2 .				
	103	14.21	2662	3.17	61700	1 4 .				
	94	15.61	2927	3.17	61700	1 6 .				
	81	18.2	3407	3.17	61700	1 8 .				
73	20.17	3787	3.12	61700	2 0 .					
67	21.93	4112	2.99	61700	2 2 .					
61	24.29	4555	2.7	61311	2 5 .					
51	28.99	5449	2.22	61311	2 8 .					
45	32.83	6173	1.96	60875	3 2 .					
42	34.93	6534	1.88	60318	3 6 .					
37	39.55	7413	1.66	60318	4 0 .					
31	46.81	8776	1.38	59900	4 5 .					
28	52.76	9891	1.22	59900	5 0 .					
26	56.39	10519	1.17	59324	5 6 .					
23	63.57	11856	1.04	59324	6 3 .					
20	74.62	13932	0.87	58400	7 1 .					
6 POLE	122	8.03	2262	1.29	34000	K 0 9 3 1 8 . 0 _ M _ _ _ 3 0 . C _ _	520	D225M		
	101	9.68	2721	1.29	34000	1 0 .				
	89	11.06	3111	1.04	34000	1 1 .				
	79	12.4	3491	0.96	34000	1 2 .				
	74	13.33	3745	1.04	34000	1 4 .				
	66	14.94	4199	0.96	34000	1 6 .				
	119	8.26	2326	1.76	35300	K 1 0 3 1 8 . 0 _ M _ _ _ 3 0 . C _ _			644	D225M
	99	9.95	2791	1.76	35300	1 0 .				
	85	11.54	3250	1.76	35300	1 1 .				
	78	12.55	3540	1.76	35300	1 2 .				
	71	13.89	3908	1.76	35300	1 4 .				
	65	15.11	4251	1.69	35300	1 6 .				
	53	18.57	5243	1.37	35300	1 8 .				
	49	20.05	5649	1.27	35300	2 0 .				
	44	22.35	6288	1.14	35300	2 2 .				
	41	24.13	6794	1.06	35300	2 5 .				
	34	29.24	8253	0.87	35300	2 8 .				
	115	8.51	2394	2.11	61700	K 1 2 3 1 8 . 0 _ M _ _ _ 3 0 . C _ _	779	D225M		
	96	10.26	2877	2.11	61700	1 0 .				
	83	11.8	3322	2.11	61700	1 1 .				
	76	12.96	3653	2.11	61700	1 2 .				
	69	14.21	3994	2.11	61700	1 4 .				
	63	15.61	4391	2.11	61668	1 6 .				
	54	18.2	5110	2.11	61636	1 8 .				
49	20.17	5678	2.11	61605	2 0 .					
45	21.93	6168	1.99	61605	2 2 .					
40	24.29	6833	1.8	61605	2 5 .					
34	28.99	8174	1.48	61587	2 8 .					
30	32.83	9260	1.31	61587	3 2 .					
28	34.93	9822	1.25	61570	3 6 .					
25	39.55	11122	1.11	61570	4 0 .					
21	46.81	13170	0.92	61532	4 5 .					
19	52.76	14816	0.82	61520	5 0 .					

NOTE
Other output speeds are available using 2 and 8 pole motors - Consult Textron Power Transmission

0205

37.0 kW	N2 R/MIN	i	M2 Nm	Fm	N	Unit Designation	Kg	Motor Size				
	Output Speed	Ratio	Output Torque	Service Factor	Overhung Load	Column Entry <input type="text" value="1"/> Through <input type="text" value="20"/> Spaces to be filled when entering order	Weight of base mount unit					
4 POLE	184	8.03	1843	1.39	34000	K 0 9 3 1 8 . 0 _ M _ _ _ 3 7 . A _ _	485	D225S				
	152	9.68	2223	1.39	34000	1 0 .						
	133	11.06	2541	1.18	34000	1 1 .						
	119	12.4	2846	1.1	34000	1 2 .						
	111	13.33	3059	1.18	34000	1 4 .						
	99	14.94	3428	1.1	34000	1 6 .						
	82	17.93	4136	0.84	34000	1 8 .						
	68	21.61	4965	0.84	34000	2 2 .						
		179	8.26	1902	2.15	35534	K 1 0 3 1 8 . 0 _ M _ _ _ 3 7 . A _ _	609	D225S			
		148	9.95	2288	2.15	35534	1 0 .					
		128	11.54	2665	2.15	35534	1 1 .					
		118	12.55	2895	2.13	35534	1 2 .					
		106	13.89	3200	2.15	35534	1 4 .					
		98	15.11	3482	2.06	35530	1 6 .					
		79	18.57	4289	1.64	35530	1 8 .					
		74	20.05	4625	1.55	35526	2 0 .					
		66	22.35	5148	1.4	35526	2 2 .					
		61	24.13	5552	1.29	35526	2 5 .					
		50	29.24	6757	1.06	35526	2 8 .					
		45	33.1	7646	0.94	35500	3 2 .					
		42	35.19	8121	0.89	35500	3 6 .					
			173	8.51	1962	2.58	61245			K 1 2 3 1 8 . 0 _ M _ _ _ 3 7 . A _ _	744	D225S
			144	10.26	2357	2.58	61326			1 0 .		
			125	11.8	2722	2.58	61175			1 1 .		
			114	12.96	2993	2.58	61186			1 2 .		
			104	14.21	3272	2.58	61350			1 4 .		
			94	15.61	3598	2.58	61373			1 6 .		
			81	18.2	4187	2.58	61198			1 8 .		
73	20.17		4655	2.53	61151	2 0 .						
67	21.93		5055	2.43	61315	2 2 .						
61	24.29		5599	2.2	60972	2 5 .						
51	28.99		6698	1.81	60972	2 8 .						
45	32.83		7588	1.59	60490	3 2 .						
42	34.93		8032	1.53	59781	3 6 .						
37	39.55		9111	1.35	59781	4 0 .						
32	46.81		10787	1.12	59200	4 5 .						
28	52.76		12157	1	59200	5 0 .						
26	56.39		12930	0.95	58400	5 6 .						
23	63.57		14572	0.84	58400	6 3 .						
6 POLE	115		8.51	2953	1.71	61700	K 1 2 3 1 8 . 0 _ M _ _ _ 3 7 . C _ _	856	D250M			
	96		10.26	3548	1.71	61700	1 0 .					
	83	11.8	4097	1.71	61700	1 1 .						
	76	12.96	4505	1.71	61700	1 2 .						
	69	14.21	4926	1.71	61700	1 4 .						
	63	15.61	5416	1.71	61649	1 6 .						
	54	18.2	6303	1.71	61598	1 8 .						
	49	20.17	7003	1.71	61547	2 0 .						
	45	21.93	7607	1.62	61547	2 2 .						
	40	24.29	8427	1.46	61547	2 5 .						
	34	28.99	10081	1.2	61535	2 8 .						
	30	32.83	11420	1.06	61535	3 2 .						
	28	34.93	12114	1.02	61522	3 6 .						
	25	39.55	13717	0.9	61522	4 0 .						

NOTE
Other output speeds are available using 2 and 8 pole motors - Consult Textron Power Transmission

0205

45.0 kW	N2 R/MIN	i	M2 Nm	Fm	N	Unit Designation	Kg	Motor Size		
	Output Speed	Ratio	Output Torque	Service Factor	Overhung Load	Column Entry <input type="text" value="1"/> Through <input type="text" value="20"/> Spaces to be filled when entering order	Weight of base mount unit			
4 POLE	184	8.03	2242	1.15	34000	K 0 9 3 1 8 . 0 _ M _ _ _ 4 5 . A _ _	520	D225M		
	152	9.68	2704	1.15	34000	1 0 .				
	133	11.06	3090	0.97	34000	1 1 .				
	119	12.4	3461	0.9	34000	1 2 .				
	111	13.33	3720	0.97	34000	1 4 .				
	99	14.94	4169	0.9	34000	1 6 .				
	179	8.26	2313	1.77	35500	K 1 0 3 1 8 . 0 _ M _ _ _ 4 5 . A _ _	644	D225M		
	148	9.95	2783	1.77	35500	1 0 .				
	128	11.54	3241	1.77	35500	1 1 .				
	118	12.55	3521	1.75	35500	1 2 .				
	106	13.89	3891	1.77	35500	1 4 .				
	98	15.11	4235	1.7	35500	1 6 .				
	79	18.57	5216	1.35	35500	1 8 .				
	74	20.05	5625	1.27	35500	2 0 .				
	66	22.35	6261	1.15	35500	2 2 .				
	61	24.13	6752	1.06	35500	2 5 .				
	50	29.24	8218	0.87	35500	2 8 .				
	173	8.51	2386	2.12	60725	K 1 2 3 1 8 . 0 _ M _ _ _ 4 5 . A _ _			779	D225M
	144	10.26	2867	2.12	60900	1 0 .				
	125	11.8	3310	2.12	60575	1 1 .				
	114	12.96	3640	2.12	60600	1 2 .				
	104	14.21	3980	2.12	60950	1 4 .				
	94	15.61	4376	2.12	61000	1 6 .				
	81	18.2	5093	2.12	60625	1 8 .				
	73	20.17	5661	2.08	60525	2 0 .				
	67	21.93	6148	2	60875	2 2 .				
	61	24.29	6809	1.81	60583	2 5 .				
	51	28.99	8147	1.49	60583	2 8 .				
45	32.83	9228	1.31	60050	3 2 .					
42	34.93	9768	1.26	59167	3 6 .					
37	39.55	11081	1.11	59167	4 0 .					
32	46.81	13119	0.92	58400	4 5 .					
28	52.76	14786	0.82	58400	5 0 .					
6 POLE	115	8.51	3591	1.41	61700	K 1 2 3 1 8 . 0 _ M _ _ _ 4 5 . C _ _	981	D280S		
	96	10.26	4315	1.41	61700	1 0 .				
	83	11.8	4983	1.41	61700	1 1 .				
	76	12.96	5480	1.41	61700	1 2 .				
	69	14.21	5991	1.41	61700	1 4 .				
	63	15.61	6587	1.41	61627	1 6 .				
	54	18.2	7666	1.41	61554	1 8 .				
	49	20.17	8518	1.41	61482	2 0 .				
	45	21.93	9252	1.33	61482	2 2 .				
	40	24.29	10249	1.2	61482	2 5 .				
	34	28.99	12261	0.99	61475	2 8 .				
	30	32.83	13890	0.87	61475	3 2 .				
	28	34.93	14733	0.83	61468	3 6 .				

NOTE
Other output speeds are available using 2 and 8 pole motors - Consult Textron Power Transmission

0205

55.0 kW	N2 R/MIN	i	M2 Nm	Fm	N	Unit Designation	Kg	
	Output Speed	Ratio	Output Torque	Service Factor	Overhung Load	Column Entry 1 Through 20 Spaces to be filled when entering order	Weight of base mount unit	Motor Size
4 POLE	173	8.51	2916	1.73	60075	K 1 2 3 1 8 . 0 _ M _ _ _ 5 5 . A _ _	856	D250M
	144	10.26	3504	1.73	60366	1 0 .		
	125	11.8	4046	1.73	59825	1 1 .		
	114	12.96	4449	1.73	59866	1 2 .		
	104	14.21	4864	1.73	60450	1 4 .		
	94	15.61	5349	1.73	60533	1 6 .		
	81	18.2	6225	1.73	59908	1 8 .		
	73	20.17	6919	1.71	59741	2 0 .		
	67	21.93	7514	1.64	60325	2 2 .		
	61	24.29	8323	1.48	60098	2 5 .		
	51	28.99	9957	1.22	60098	2 8 .		
	45	32.83	11279	1.07	59500	3 2 .		
	42	34.93	11939	1.03	58400	3 6 .		
	37	39.55	13544	0.91	58400	4 0 .		
	6 POLE	115	8.51	4390	1.15	61700		
96		10.26	5274	1.15	61700	1 0 .		
83		11.8	6090	1.15	61700	1 1 .		
76		12.96	6697	1.15	61700	1 2 .		
69		14.21	7322	1.15	61700	1 4 .		
63		15.61	8051	1.15	61600	1 6 .		
54		18.2	9370	1.15	61500	1 8 .		
49		20.17	10411	1.15	61400	2 0 .		
45		21.93	11308	1.09	61400	2 2 .		
40		24.29	12527	0.98	61400	2 5 .		
34		28.99	14986	0.81	61400	2 8 .		

NOTE
Other output speeds are available using 2 and 8 pole motors - Consult Textron Power Transmission

0205

75.0 kW	N2 R/MIN	i	M2 Nm	Fm	N	Unit Designation	Kg	
	Output Speed	Ratio	Output Torque	Service Factor	Overhung Load	Column Entry <input type="text" value="1"/> Through <input type="text" value="20"/> Spaces to be filled when entering order	Weight of base mount unit	Motor Size
4 POLE	174	8.51	3950	1.28	58775	K 1 2 3 1 8 . 0 _ M _ _ _ 7 5 . A _ _	981	D280S
	145	10.26	4746	1.28	59300	1 0 .		
	126	11.8	5480	1.28	58325	1 1 .		
	115	12.96	6027	1.28	58400	1 2 .		
	104	14.21	6589	1.28	59450	1 4 .		
	95	15.61	7245	1.28	59600	1 6 .		
	82	18.2	8431	1.28	58475	1 8 .		
	74	20.17	9372	1.26	58175	2 0 .		
	68	21.93	10178	1.21	59225	2 2 .		
	61	24.29	11273	1.09	59127	2 5 .		
	51	28.99	13487	0.9	59127	2 8 .		
	90.0 kW	N2 R/MIN	i	M2 Nm	Fm	N		
Output Speed	Ratio	Output Torque	Service Factor	Overhung Load	Column Entry <input type="text" value="1"/> Through <input type="text" value="20"/> Spaces to be filled when entering order	Weight of base mount unit	Motor Size	
4 POLE	174	8.51	4740	1.07	57800	K 1 2 3 1 8 . 0 _ M _ _ _ 9 0 . A _ _	1071	D280M
	145	10.26	5696	1.07	58500	1 0 .		
	126	11.8	6576	1.07	57200	1 1 .		
	115	12.96	7232	1.07	57300	1 2 .		
	104	14.21	7907	1.07	58700	1 4 .		
	95	15.61	8694	1.07	58900	1 6 .		
	82	18.2	10118	1.07	57400	1 8 .		
	74	20.17	11246	1.05	57000	2 0 .		
	68	21.93	12213	1.01	58400	2 2 .		
	61	24.29	13528	0.91	58400	2 5 .		

NOTE
Other output speeds are available using 2 and 8 pole motors - Consult Textron Power Transmission

0205

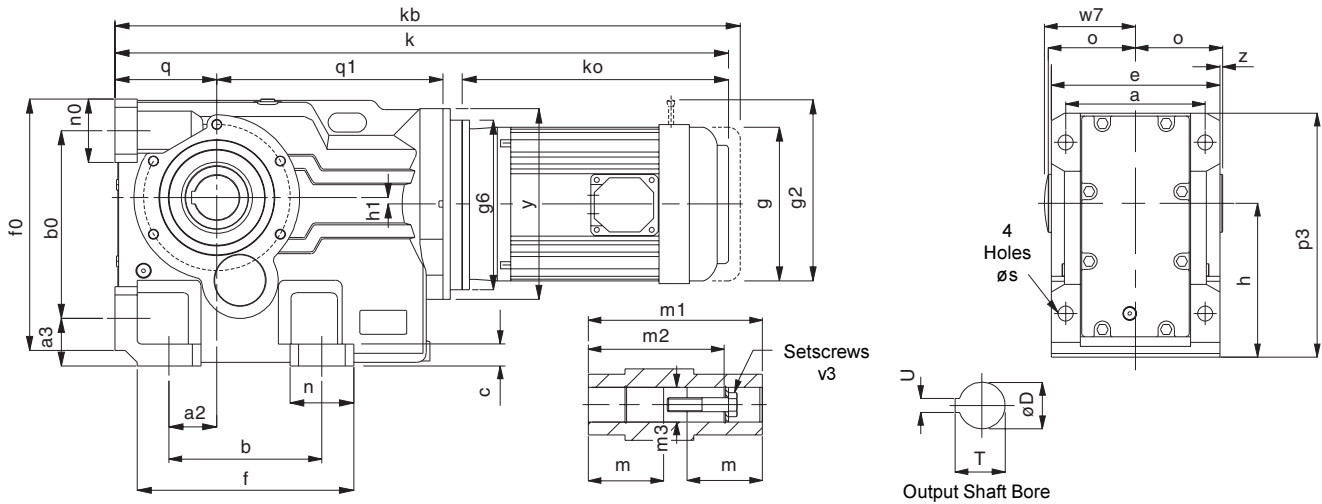

SIZE	a	a2	a3	b	b0	c	e	f	f0	h	h1	n	n0	o	p3
K0332	100	28	32	110	115	11	120	143	152	100	16	38	38	60	167
K0432	120	35	37	130	130	16	145	168	171	112	13	38	40	75	187
K0532	130	30	45	130	150	15	157	170	192	132	5	40	40	83	217
K0632	140	30	45	120	160	20	170	176	208	140	13	55	48	90	233
K0732	165	40	55	150	200	27	200	210	263	180	25	60	55	105	288
K0832	180	55	70	180	233	30	230	256	309	212	15	76	76	120	341
K0931	240	75	75	240	295	35	290	340	395	265	10	100	100	150	420
K1031	270	95	95	280	360	40	340	390	455	315	41	110	115	175	513
K1231	330	115	110	350	420	45	400	470	540	375	65	120	120	205	590

SIZE	q	q1	s	w7	y	z	Hollow Output Bore							
							D	m	m1	m2	m3	T	U	v3
K0332	63	159	11	63	140	0	30	52.5	120	105	30.3	33.5	8	M10x50L
K0432	71	179	11	78	140	2.5	35	66	150	132	35.3	38.5	10	M12x55L
K0532	80	219	14	87	180	4.5	40	73	166	142	40.3	43.5	12	M16x70L
K0632	90	229	14	94	180	5	40	80	180	156	40.3	43.5	12	M16x70L
K0732	112	265	18	109	212	5	50	92.5	210	183	50.5	54	14	M16x70L
K0832	132	330	23	124	250	5	60	105	240	210	60.5	64.5	18	M20x80L
K0931	160	355	27	154	300	5	70	132.5	300	270	70.5	75	20	M20x80L
K1031	200	423	34	180	360	5	80	155	350	313	80.5	85.5	22	M20x80L
K1231	225	476	39	210	400	5	100	180	410	373	100.5	106.5	28	M24x110L

Motor Frame Size	All Sizes					K0332		K0432		K0532		K0632		M0732		K0832		K0931		K1031		K1231	
	ko	g	g1**	g2	g6	k	kb	k	kb	k	kb	k	kb	k	kb	k	kb	k	kb	k	kb	k	kb
63	218	122	96	160	140	474	519	502	547														
71	221	138	102	167	105	481	526	509	554														
80A	239	157	125	190	120	512	565	540	593	574	627	594	647	653	706	748	801	812	865				
80B	248	157	125	190	120	521	574	549	602	583	636	603	656	662	715	757	810	821	874				
90S	260	177	133	218	140	543	595	571	623	605	657	625	677	684	736	769	821	833	885				
90L	275	177	133	218	140	558	610	586	638	620	672	640	692	699	751	784	836	848	900				
90LA	284	177	133	218	140	567	619	595	647	629	681	649	701	708	760	793	845	857	909				
100L	310	197	144	238	160					680	740	700	760	744	804	825	885	889	949	980	1040	1107	1167
112M	325	219	155	238	160					695	769	715	789	759	833	840	914	904	978	995	1069	1122	1196
112MA	344	219	155	238	160					714	788	734	808	778	852	859	933	923	997	1014	1088	1141	1215
132SA	392	235	172	288	200									828	911	907	990	971	1054	1062	1145	1189	1272
132M	412	235	172	288	200									848	931	927	1010	991	1074	1082	1165	1209	1292
132MA	436	235	172	288	200									772	855	851	934	915	998	1006	1089	1133	1216
132MB	472	235	172	288	200									908	991	987	1070	1051	1134	1142	1225	1269	1352
160M	455	273	282	325	350											1000	1083	1069	1152	1160	1243	1246	1329
160L	500	273	282	325	350											1045	1128	1114	1197	1205	1288	1291	1374
180M	557	382	307		350														1171		1262		1348
180L	595	382	307		350														1209		1300		1386
200L	658	420	372		400														1272		1363		1449
225S	671	458	427		450														1312		1403		1489
225M	696	458	427		450														1336		1427		1513
250M	771	510	490		550																		1644
280S	837	576	520		550																		1710
280M	888	576	520		550																		1761

** Dimension over terminal box from centreline

0205

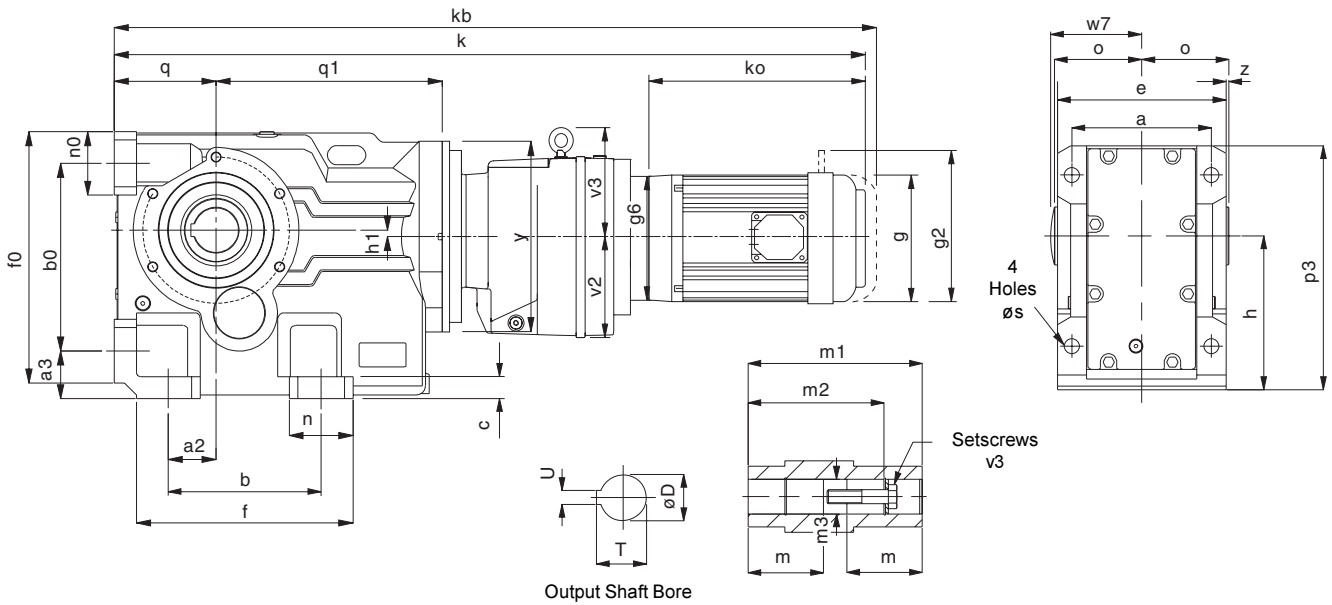

SIZE	a	a2	a3	b	b0	c	e	f	f0	h	h1	n	n0	o	p3	q
K0352	100	28	32	110	115	11	120	143	152	100	16	38	38	60	167	63
K0452	120	35	37	130	130	16	145	168	171	112	13	38	40	75	187	71
K0552	130	30	45	130	150	15	157	170	192	132	5	40	40	83	217	80
K0652	140	30	45	120	160	20	170	176	208	140	13	55	48	90	233	90
K0752	165	40	55	150	200	27	200	210	263	180	25	60	55	105	288	112
K0852	180	55	70	180	233	30	230	256	309	212	15	76	76	120	341	132
K0951	240	75	75	240	295	35	290	340	395	265	10	100	100	150	420	160
K1051	270	95	95	280	360	40	340	390	455	315	41	110	115	175	513	200
K1251	330	115	110	350	420	45	400	470	540	375	65	120	120	205	590	225

SIZE	q1	s	v2	v3	w7	y	z	Hollow Output Bore							
								D	m	m1	m2	m3	T	U	v3
K0352	159	11	76	-	63	140	0	30	52.5	120	105	30.3	33.5	8	M10x50L
K0452	179	11	76	-	78	140	2.5	35	66	150	132	35.3	38.5	10	M12x55L
K0552	219	13.5	91	-	87	180	4.5	40	73	166	142	40.3	43.5	12	M16x70L
K0652	229	14	91	-	94	180	5	40	80	180	156	40.3	43.5	12	M16x70L
K0752	265	18	91	-	109	212	5	50	92.5	210	183	50.5	54	14	M16x70L
K0852	330	23	115	-	124	250	5	60	105	240	210	60.5	64.5	18	M20x80L
K0951	355	27	115	-	154	300	5	70	132.5	300	270	70.5	75	20	M20x80L
K1051	423	34	140	155	180	360	5	80	155	350	313	80.5	85.5	22	M20x80L
K1251	476	39	140	155	210	400	5	100	180	410	373	100.5	106.5	28	M24x110L

Motor Frame Size	All Sizes					K0352		K0452		K0552		K0652		M0752		K0852		K0951		K1051		K1251	
	ko	g	g1**	g2	g6	k	kb	k	kb	k	kb	k	kb	k	kb	k	kb	k	kb	k	kb	k	kb
63	218	122	96	160	140	771	816	799	844	866	911	886	931	945	990								
71	221	138	102	167	105	778	823	806	851	871	916	891	936	950	995								
80A	239	157	125	190	120	809	862	837	890	902	955	922	975	981	1034	1093	1146	1157	1210	1306	1359	1433	1486
80B	248	157	125	190	120	818	871	846	899	911	964	931	984	990	1043	1102	1155	1166	1219	1315	1368	1442	1495
90S	260	177	133	218	140	840	892	868	920	933	985	953	1005	1012	1064	1124	1176	1188	1240	1337	1389	1464	1516
90L	275	177	133	218	140	855	907	883	935	948	1000	968	1020	1027	1079	1139	1191	1203	1255	1352	1404	1479	1531
90LA	284	177	133	218	140	864	916	892	944	957	1009	977	1029	1036	1088	1148	1200	1212	1264	1361	1413	1488	1540
100L	310	197	144	238	160											1199	1259	1263	1323	1397	1457	1524	1584
112M	325	219	155	238	160											1214	1288	1278	1352	1412	1486	1539	1613
112MA	344	219	155	238	160											1233	1307	1297	1371	1431	1505	1558	1632
132SA	392	235	172	288	200															1481	1564	1608	1691
132M	412	235	172	288	200															1501	1584	1628	1711
132MA	436	235	172	288	200															1425	1508	1552	1635
132MB	472	235	172	288	200															1561	1644	1688	1771

** Dimension over terminal box from centreline

0203

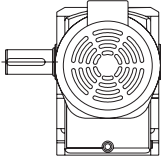

Single Extended Outputshaft

See Page 82

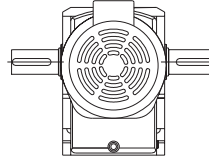

Double Extended Outputshaft

See Page 82

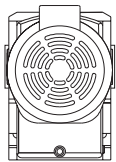

Kibo Bushes

See Pages 83 - 84

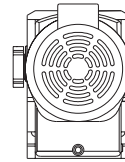

Taper Release Bushing

See Pages 86 - 87

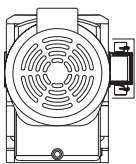

Shrink Disc

See Page 85



Torque Bracket

See Page 88

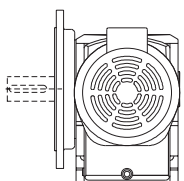

B5 (D) Flange Mounting

See Page 89

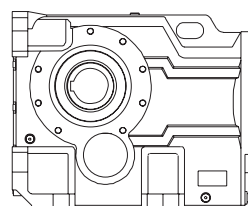

B14 (C) Flange Mounting

See Page 90

0106

Motorised backstop modules can be fitted between the gear unit and motor. The backstop device incorporates high quality centrifugal lift off sprags which are wear free above the lift off speed (n min). To ensure correct operation motor speed must exceed lift off speed.

Suitable for ambient temperature -40°C to + 50°C

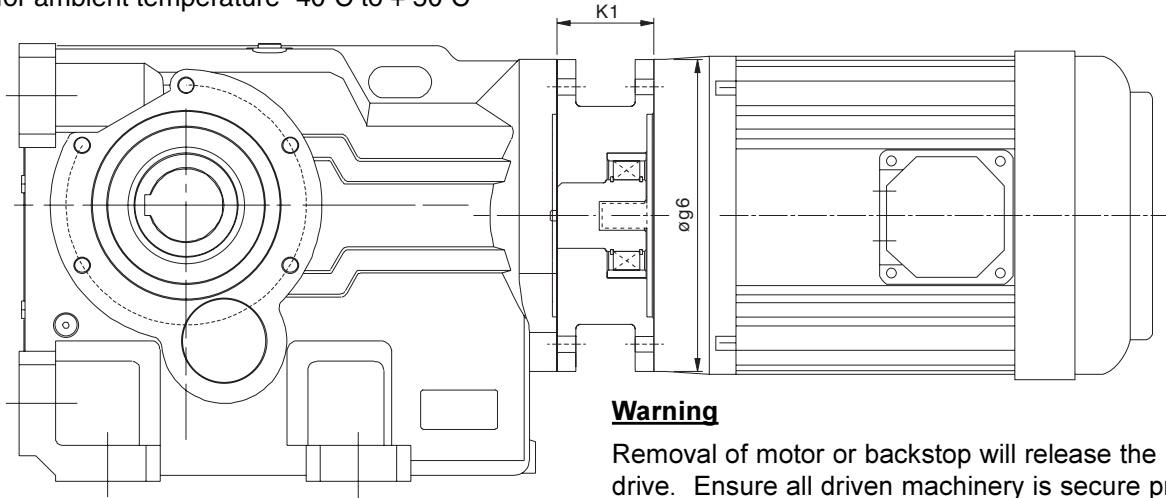

Warning

Removal of motor or backstop will release the drive. Ensure all driven machinery is secure prior to any maintenance work

IEC B5 FLANGE

Motor Frame Size	Lift off Speed ('n' min) (rev/min)	Rated Locking Torque ('T max') (at motor) (Nm)	øg6	K1
100	670	170	250	70
112	670	170	250	70
132	620	940	300	95
160	620	940	350	130
180	620	940	350	130
200	550	1260	400	130

NEMA C FLANGE

Motor Frame Size	Lift off Speed ('n' min) (rev/min)	Rated Locking Torque ('T max') (at motor) (Nm)	øg6	K1
182TC / 184TC	670	300	228	95.25
213TC / 215 TC	670	300	228	95.25
254TC / 256TC	620	940	228	120.65
284TC / 286TC	620	940	280	136.50
324TC / 326TC	550	1260	330	152.4

When a backstop module is fitted dimension K1 should be added to the overall length of the geared motor assembly.

Rotation of outputshaft must be specified when ordering as viewed from the outputshaft end (as shown in the diagram) see page 20 for column 20 entry

- CW - Free Rotation - Clockwise
- Locked - Anticlockwise
- AC - Free Rotation - Anticlockwise
- Locked - Clockwise

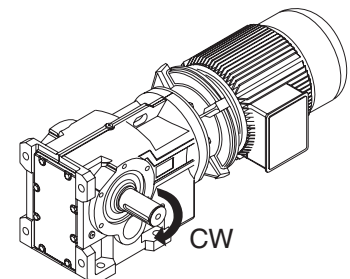

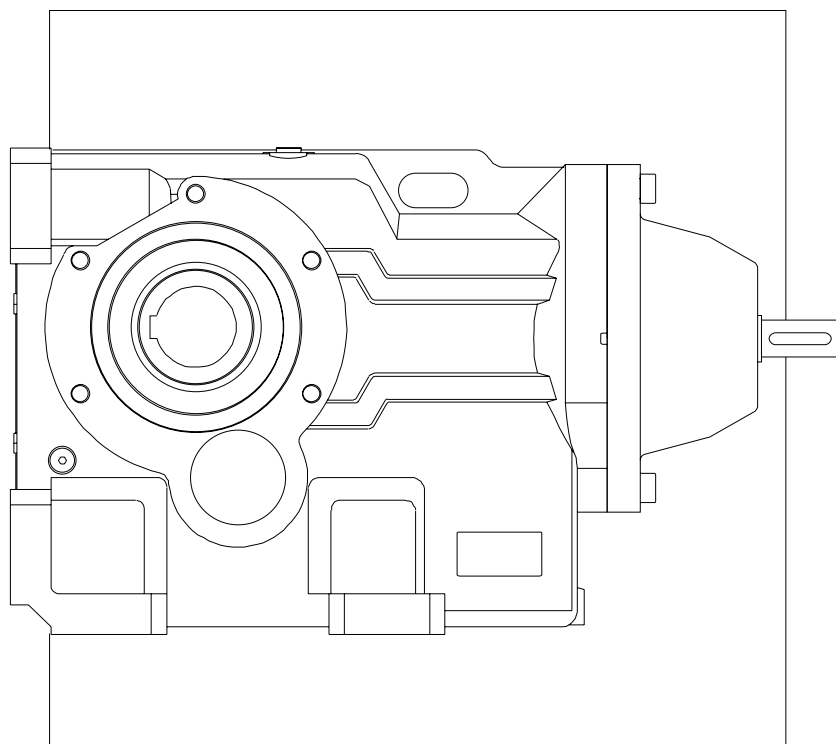

REDUCER SERIES K

TEXTRON POWER TRANSMISSION

0106

Maximum permissible overhung loads

When a sprocket, gear etc. is mounted on the shaft a calculation, as below, must be made to determine the overhung load on the shaft, and the results compared to the maximum permissible overhung loads tabulated. Overhung loads can be reduced by increasing the diameter of the sprocket, gear, etc. If the maximum permissible overhung load is exceeded, the sprocket, gear, etc. should be mounted on a separate shaft, flexibly coupled and supported in its own bearings, or the gear unit shaft should be extended to run in an outboard bearing. Alternatively, a larger gear is often a less expensive solution.

Permissible overhung loads vary according to the direction of rotation. The values tabulated are for the most unfavourable direction with the unit transmitting full rated power and the load P applied midway along the shaft extension. Hence they can sometimes be increased for a more favourable direction of rotation, or if the power transmitted is less than the rated capacity of the gear unit, or if the load is applied nearer to the gear unit case. Refer to Textron Power Transmission for further details. In any event, the sprocket, gear etc. should be positioned as close as possible to the gear unit case in order to reduce bearing loads and shaft stresses, and to prolong life.

All units will accept 100% momentary overload on stated capacities.

Overhung load (Newtons)

$$P = \frac{kW \times 9,500,000 \times K}{N \times R}$$

where

- P = equivalent overhung load (Newtons)
- kW = power transmitted by the shaft (kilowatts)
- N = speed of shaft (rev/min)
- R = pitch radius of sprocket, etc. (mm)
- K = factor

Overhung member	K (factor)
Chain sprocket*	1.00
Spur or helical pinion	1.25
Vee belt sheave	1.50
Flat belt pulley	2.00

* If multistrand chain drives are equally loaded and the outer strand is further than dimension A output or B input, refer to Textron Power Transmission.

Note: 1 Newton = 0.101972 kp = 0.227809 lbf.

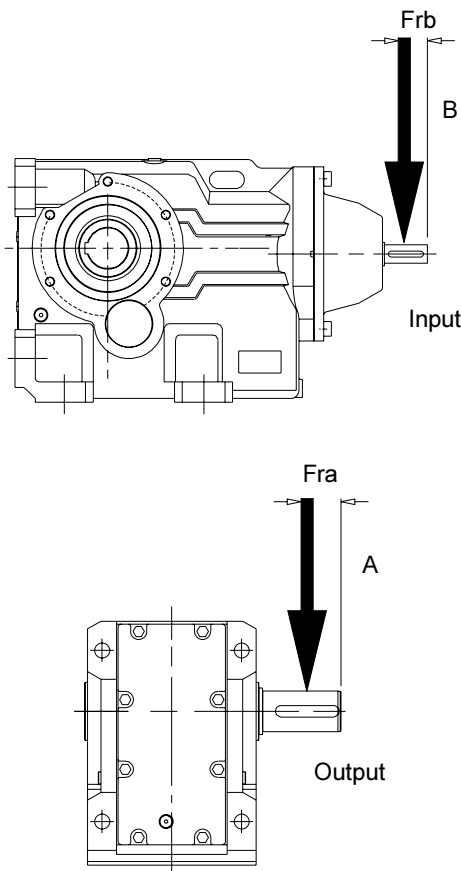

Distance midway along the shaft extension

Size of unit	No. of Reductions	Dimension A (mm)	Dimension B (mm)
K03	3	23.5	20
	5	23.5	20
K04	3	28	20
	5	28	20
K05	3	33	20
	5	33	20
K06	3	38	20
	5	38	20
K07	3	47.5	25
	5	47.5	20
K08	3	50	30
	5	50	20
K09	3	55	40
	5	55	20
K10	3	70	55
	5	70	25
K12	3	90	55
	5	90	25

Axial Thrust Capacities (Newtons)

Permissible axial thrust capacities vary according to the direction of rotation and the direction of thrust, towards or away from the unit. The values tabulated are for the most unfavourable direction and hence can sometimes be increased. Similarly they can sometimes be increased if the power transmitted is less than the rated capacity of the gear unit.

Thrust capacities tabulated refer to outputshafts, and are calculated without any overhung loads being applied. In cases where combined axial thrusts and overhung loads are to be applied, refer to Textron Power Transmission.

**OVERHUNG & AXIAL LOADS (NEWTONS)
ON SHAFTS**

0208

Inputshaft Overhung Loads, Frb (Kn) 1450 rpm**Three and Five Stage Units**

	K03	K04	K05	K06	K07	K08	K09	K10	K12
3 Stage	1.50	1.50	1.25	1.05	2.1	3.1	3.5	4.5	12.0
5 Stage	1.50	1.50	1.50	1.50	1.50	1.50	1.50	1.80	1.80

For output overhung load Fra consult ratings tables pages 21 to 59

Axial Thrust Capacities (Newtons)

No check or calculation is required for axial loads (F_A) towards or away from the unit up to 50% of the permissible overhung load. If the axial thrust considerably exceeds these values or if there is a combination of axial thrust loads and overhung loads please contact Textron Power Transmission.

0105

P_m - Input Power (kW) N_2 - Output Speed (rpm)
 M_2 - Output Torque (Nm) fra - Overhung Load (kN)
 i - Exact Ratio (:1)

TRIPLE REDUCTION

Column Entry 6 7 8			K0332				K0432					K0532						
			Input Speed N1 (rpm)	N2 (rpm)	i (:1)	M2 (Nm)	Pm (kW)	fra (kN)	N2 (rpm)	i (:1)	M2 (Nm)	Pm (kW)	fra (kN)	N2 (rpm)	i (:1)	M2 (Nm)	Pm (kW)	fra (kN)
8	.	0	2900	348	8.328	118	4.49	2.88	360	8.054	215	8.48	3.23	358	8.112	323	12.7	2.33
			1450	174		137	2.6	3.46	180		256	5.02	3.67	179		394	7.66	2.65
			960	115		150	1.87	4.04	119		279	3.61	4.33	118		429	5.5	3.20
			725	87		159	1.5	4.49	90		296	2.88	4.84	89		451	4.37	3.66
1	1	.	2900	258	11.25	135	3.78	3.02	257	11.296	255	7.16	3.33	254	11.405	381	10.6	2.35
			1450	129		155	2.17	3.71	128		294	4.1	3.93	127		448	6.19	2.84
			960	85		170	1.57	4.34	85		320	2.95	4.65	84		484	4.42	3.45
			725	64		179	1.25	4.83	64		338	2.35	5.13	64		511	3.52	3.94
1	2	.	2900	227	12.796	141	3.47	3.15	233	12.448	265	6.73	3.44	227	12.783	401	9.93	2.37
			1450	113		163	2	3.97	116		305	3.86	4.20	113		466	5.74	3.04
			960	75		177	1.44	4.65	77		331	2.77	4.97	75		503	4.09	3.69
			725	57		187	1.14	5.17	58		349	2.2	5.42	57		531	3.26	4.23
1	4	.	2900	200	14.497	147	3.21	3.29	205	14.135	277	6.19	3.54	202	14.349	421	9.29	2.38
			1450	100		171	1.85	4.22	103		319	3.55	4.46	101		485	5.32	3.23
			960	66		185	1.33	4.95	68		346	2.54	5.28	67		522	3.78	3.94
			725	50		195	1.06	5.50	51		364	2.02	5.71	51		551	3.01	4.51
1	8	.	2900	156	18.54	159	2.71	3.42	162	17.953	299	5.27	3.64	159	18.222	454	7.88	2.40
			1450	78		184	1.56	4.47	81		344	3.02	4.72	80		519	4.48	3.42
			960	52		200	1.12	5.25	53		372	2.16	5.60	53		561	3.2	4.18
			725	39		210	0.89	5.84	40		382	1.67	6.00	40		592	2.55	4.79
2	0	.	2900	145	19.98	163	2.57	3.61	142	20.396	312	4.83	3.84	140	20.657	471	7.21	2.57
			1450	73		189	1.48	4.72	71		358	2.76	4.99	70		537	4.09	3.65
			960	48		204	1.06	5.55	47		387	1.98	5.80	46		581	2.92	4.46
			725	36		217	0.85	6.00	36		400	1.54	6.00	35		613	2.33	5.18
2	5	.	2900	115	25.225	175	2.19	3.80	116	25.031	332	4.19	4.04	118	24.636	495	6.35	2.73
			1450	57		201	1.25	4.97	58		380	2.39	5.26	59		563	3.6	3.89
			960	38		218	0.9	5.84	38		411	1.71	6.00	39		609	2.57	4.74
			725	29		225	0.7	6.00	29		438	1.37	6.00	29		644	2.05	5.56
2	8	.	2900	101	28.597	182	2.01	3.98	104	27.762	342	3.89	4.24	102	28.367	514	5.73	2.90
			1450	51		208	1.14	5.22	52		391	2.22	5.52	51		584	3.24	4.12
			960	34		225	0.82	6.00	35		423	1.59	6.00	34		632	2.32	5.02
			725	25		225	0.62	6.00	25		430	1.22	6.00	26		659	1.82	5.95
3	2	.	2900	89	32.679	189	1.82	4.17	92	31.539	354	3.55	4.44	88	32.993	532	5.09	3.06
			1450	44		215	1.04	5.47	46		404	2.02	5.79	44		607	2.9	4.35
			960	29		225	0.71	6.00	30		435	1.44	6.00	29		658	2.08	5.30
			725	22		225	0.54	6.00	23		435	1.09	6.00	22		659	1.57	6.33
3	6	.	2900	80	36.352	194	1.69	3.42	81	35.834	375	3.31	3.42	79	36.913	559	4.79	3.13
			1450	40		221	0.96	5.74	40		428	1.89	6.00	39		638	2.72	4.42
			960	26		225	0.64	6.00	27		441	1.29	6.00	26		659	1.86	5.68
			725	20		225	0.49	6.00	20		441	0.97	6.00	20		659	1.4	6.76
4	0	.	2900	72	40.078	198	1.56	3.80	73	39.461	375	3	3.99	74	39.343	555	4.46	3.37
			1450	36		225	0.88	6.00	37		428	1.71	6.00	37		634	2.53	4.83
			960	24		225	0.58	6.00	24		441	1.17	6.00	24		659	1.74	6.06
			725	18		225	0.44	6.00	18		441	0.88	6.00	18		659	1.32	7.02
4	5	.	2900	66	44.107	203	1.45	4.19	64	45.39	388	2.7	4.56	62	46.627	578	3.91	3.61
			1450	33		225	0.8	6.00	32		441	1.53	6.00	31		658	2.22	5.24
			960	22		225	0.53	6.00	21		441	1.01	6.00	21		659	1.47	6.43
			725	16		225	0.4	6.00	16		441	0.77	6.00	16		659	1.11	7.50
5	0	.	2900	56	51.676	211	1.29	4.57	59	49.347	395	2.53	5.12	58	49.784	586	3.72	3.85
			1450	28		225	0.69	6.00	29		441	1.41	6.00	29		658	2.08	5.64
			960	19		225	0.45	6.00	19		441	0.93	6.00	19		659	1.38	6.81
			725	14		225	0.34	6.00	15		441	0.7	6.00	15		659	1.04	7.50
6	3	.	2900	47	61.997	219	1.12	4.95	49	59.241	412	2.2	5.69	47	61.777	615	3.15	4.09
			1450	23		225	0.57	6.00	24		441	1.18	6.00	23		659	1.68	6.05
			960	15		225	0.38	6.00	16		441	0.78	6.00	16		659	1.11	7.16
			725	12		225	0.29	6.00	12		441	0.59	6.00	12		659	0.84	7.50
7	1	.	2900	40	72.268	225	0.98	5.64	41	71.089	429	1.91	6.00	40	72.848	638	2.77	4.37
			1450	20		225	0.49	6.00	20		431	0.96	6.00	20		659	1.43	6.55
			960	13		225	0.32	6.00	14		431	0.64	6.00	13		659	0.94	7.50
			725	10		225	0.25	6.00	10		431	0.48	6.00	10		659	0.71	7.50
8	0	.	2900	36	80.298	225	0.89	6.00	36	80.1	433	1.72	6.00	36	79.767	650	2.58	4.66
			1450	18		225	0.44	6.00	18		433	0.86	6.00	18		659	1.31	7.04
			960	12		225	0.29	6.00	12		434	0.57	6.00	12		659	0.86	7.50
			725	9		225	0.22	6.00	9		434	0.43	6.00	9		659	0.65	7.50
1	0	0	2900	30	96.696	185	0.61	6.00	31	93.116	400	1.36	6.00	30	97.757	658	2.14	4.94
			1450	15		186	0.3	6.00	16		410	0.7	6.00	15		659	1.07	7.50
			960	10		186	0.2	6.00	10		425	0.48	6.00	10		659	0.71	7.50
			725	7		186	0.15	6.00	8		435	0.37	6.00	7		659	0.53	7.50
1	1	2	2900	26	110.833	159	0.46	6.00	27	105.688	409	1.23	6.00	27	108.958	659	1.92	5.22
			1450	13		159	0.23	6.00	14		419	0.63	6.00	13		659	0.96	7.50
			960	9		159	0.15	6.00	9		434	0.43	6.00	9		659	0.63	7.50
			725	7		159	0.11	6.00	7		441	0.33	6.00	7		659	0.48	7.50
1	2	5	2900	23	125.96	157	0.4	6.00	24	120.15	441	1.17	6.00	24	122.196	607	1.58	6.41
			1450	12		157	0.2	6.00	12		441	0.58	6.00	12		608	0.79	7.50
			960	8		157	0.13	6.00	8		441	0.39	6.00	8		608	0.52	7.50
			725	6		157	0.1	6.00	6		441	0.29	6.00	6		608	0.4	7.50

SERIES K

TRIPLE REDUCTION RATINGS

SIZES K09 - K12

0102

*P*_m - Input Power (kW) *N*₂ - Output Speed (rpm)
*M*₂ - Output Torque (Nm) *fra* - Overhung Load (kN)
i - Exact Ratio (:1)

TRIPLE REDUCTION

Column Entry			K0931				K1031				K1231							
			Input Speed N1 (rpm)	N2 (rpm)	<i>i</i> (:1)	M2 (Nm)	Pm (kW)	fra (kN)	N2 (rpm)	<i>i</i> (:1)	M2 (Nm)	Pm (kW)	fra (kN)	N2 (rpm)	<i>i</i> (:1)	M2 (Nm)	Pm (kW)	fra (kN)
8	7	0	2900	361	8.035	2090	82.8	22.9	351	8.263	4070	156	22.9	341	8.513	5240	195	56.5
			1450	180		2570	50.7	25.2	175		4090	78.2	25.2	170		5260	97.4	56.5
			960	119		2910	37.8	27.7	116		4100	51.8	34.0	113		5260	64.5	56.5
			725	90		3050	30	30.0	88		4100	39.1	34.0	85		5260	48.7	56.6
1	0	.	2900	300	9.681	2510	82.8	22.9	292	9.946	4890	156	22.9	283	10.256	6300	195	56.5
			1450	150		3100	50.7	25.2	146		4920	78.2	25.2	141		6320	97.4	56.5
			960	99		3500	37.8	27.7	97		4920	51.8	34.0	94		6320	64.5	56.5
			725	75		3670	29.9	30.0	73		4930	39.1	34.0	71		6330	48.7	56.6
1	1	.	2900	262	11.061	2430	69.8	23.5	251	11.542	4820	132	25.7	246	11.799	7290	195	56.5
			1450	131		2990	42.8	26.5	126		5730	78.2	29.6	123		7300	97.4	56.5
			960	87		3240	30.6	29.0	83		5730	51.8	35.8	81		7300	64.5	56.5
			725	66		3370	24	31.0	63		5740	39.1	36.3	61		7310	48.7	57.8
1	2	.	2900	234	12.398	2560	65.5	24.1	231	12.553	5010	126	28.5	224	12.96	8010	195	56.5
			1450	117		3130	40	27.7	116		6170	77.5	34.0	112		8020	97.4	56.5
			960	77		3350	28.2	30.3	76		6240	51.8	37.6	74		8020	64.5	56.5
			725	58		3510	22.3	32.0	58		6240	39.1	38.6	56		8030	48.7	59.0
1	4	.	2900	218	13.328	2920	69.8	24.6	209	13.893	5790	132	31.2	204	14.214	8760	195	56.5
			1450	109		3600	42.8	29.0	104		6880	78.2	35.8	102		8770	97.4	56.5
			960	72		3670	28.8	31.7	69		6890	51.8	40.1	68		8780	64.5	57.7
			725	54		3670	21.7	34.0	52		6890	39.1	43.1	51		8780	48.7	60.1
1	6	.	2900	194	14.938	3070	65.5	24.6	192	15.11	6020	126	31.2	186	15.613	9630	195	56.5
			1450	97		3670	38.9	29.5	96		7190	75.1	36.4	93		9640	97.4	56.5
			960	64		3670	25.7	32.5	64		7190	49.7	41.5	61		9640	64.5	57.8
			725	49		3670	19.4	34.0	48		7190	37.5	43.1	46		9650	48.7	61.3
1	8	.	2900	162	17.933	2980	52.8	25.2	156	18.571	5920	101	34.0	159	18.203	9410	163	56.5
			1450	81		3480	30.6	30.3	78		7040	59.7	37.6	80		11300	97.4	56.5
			960	54		3670	21.3	33.1	52		7190	40.3	42.5	53		11300	64.5	58.9
			725	40		3670	16.1	34.0	39		7190	30.4	43.1	40		11300	48.7	61.3
2	0	.	2900	145	20.035	3110	49.3	26.5	145	20.05	6100	96.1	34.9	144	20.166	9800	153	56.5
			1450	72		3560	28.1	31.2	72		7160	56.3	39.0	72		11800	92.2	57.7
			960	48		3670	19.1	34.0	48		7190	37.4	43.1	48		12100	62.4	61.3
			725	36		3670	14.4	34.0	36		7190	28.2	43.1	36		12100	47.1	61.3
2	2	.	2900	134	21.608	3590	52.8	27.0	130	22.354	7110	101	35.4	132	21.93	11300	163	56.6
			1450	67		3670	26.9	32.5	65		7190	50.8	41.5	66		12300	88.5	59.8
			960	44		3670	17.8	34.0	43		7190	33.6	43.1	44		12300	58.6	61.3
			725	34		3670	13.4	34.0	32		7190	25.4	43.1	33		12300	44.2	61.3
2	5	.	2900	120	24.14	3670	48.3	27.8	120	24.134	7190	94.3	35.8	119	24.294	11800	153	56.5
			1450	60		3670	24.1	32.2	60		7190	47.1	40.4	60		12300	79.9	58.9
			960	40		3670	15.9	34.0	40		7190	31.1	43.1	40		12300	52.9	61.3
			725	30		3670	12	34.0	30		7190	23.5	43.1	30		12300	39.9	61.3
2	8	.	2900	104	27.777	3460	39.4	29.0	99	29.239	7050	76.1	36.7	100	28.995	11400	124	56.5
			1450	52		3670	20.8	34.0	50		7190	38.7	43.1	50		12100	65.7	61.3
			960	35		3670	13.8	34.0	33		7190	25.6	43.1	33		12100	43.5	61.3
			725	26		3670	10.4	34.0	25		7190	19.3	43.1	25		12100	32.8	61.3
3	2	.	2900	92	31.672	3550	35.6	30.3	88	33.099	7190	68.6	37.6	88	32.831	11700	112	56.5
			1450	46		3670	18.3	34.0	44		7190	34.2	43.1	44		12100	58	61.3
			960	30		3670	12.1	34.0	29		7190	22.6	43.1	29		12100	38.4	61.3
			725	23		3670	9.13	34.0	22		7190	17.1	43.1	22		12100	29	61.3
3	6	.	2900	87	33.469	3670	34.8	31.8	82	35.195	7190	64.7	39.5	83	34.931	12300	111	59.3
			1450	43		3670	17.3	34.0	41		7190	32.2	43.1	42		12300	55.7	61.3
			960	29		3670	11.5	34.0	27		7190	21.3	43.1	27		12300	36.8	61.3
			725	22		3670	8.65	34.0	21		7190	16.1	43.1	21		12300	27.8	61.3

0102

P_m - Input Power (kW) *N₂* - Output Speed (rpm)
M₂ - Output Torque (Nm) *fra* - Overhung Load (kN)
i - Exact Ratio (:1)

TRIPLE REDUCTION

Column Entry	Input Speed N1 (rpm)	K0931					K1031					K1231				
		N2 (rpm)	i (:1)	M2 (Nm)	Pm (kW)	fra (kN)	N2 (rpm)	i (:1)	M2 (Nm)	Pm (kW)	fra (kN)	N2 (rpm)	i (:1)	M2 (Nm)	Pm (kW)	fra (kN)
4 0 .	2900	76	38.162	3670	30.5	32.4	73	39.841	7190	57.1	40.4	73	39.553	12300	98.4	59.8
	1450	38		3670	15.2	34.0	36		7190	28.5	43.1	37		12300	49.1	61.3
	960	25		3670	10.1	34.0	24		7190	18.8	43.1	24		12300	32.5	61.3
	725	19		3670	7.59	34.0	18		7190	14.2	43.1	18		12300	24.5	61.3
4 5 .	2900	65	44.892	3670	25.9	32.9	64	45.366	7190	50.1	41.3	62	46.81	12100	81.8	60.3
	1450	32		3670	12.9	34.0	32		7190	25	43.1	31		12100	40.8	61.3
	960	21		3670	8.54	34.0	21		7190	16.5	43.1	21		12100	27	61.3
	725	16		3670	6.45	34.0	16		7190	12.5	43.1	15		12100	20.4	61.3
5 0 .	2900	58	49.875	3670	23.3	33.5	58	50.412	7190	45.1	42.2	55	52.764	12100	72.5	60.8
	1450	29		3670	11.6	34.0	29		7190	22.5	43.1	27		12100	36.2	61.3
	960	19		3670	7.69	34.0	19		7190	14.9	43.1	18		12100	24	61.3
	725	15		3670	5.81	34.0	14		7190	11.2	43.1	14		12100	18.1	61.3
5 6 .	2900	54	54.091	3670	21.6	34.0	53	54.607	7190	41.7	43.1	51	56.394	12300	69.3	61.3
	1450	27		3670	10.7	34.0	27		7190	20.8	43.1	26		12300	34.6	61.3
	960	18		3670	7.11	34.0	18		7190	13.8	43.1	17		12300	22.9	61.3
	725	13		3670	5.36	34.0	13		7190	10.4	43.1	13		12300	17.3	61.3
6 3 .	2900	48	60.095	3670	19.4	34.0	48	60.681	7190	37.6	43.1	46	63.567	12300	61.4	61.3
	1450	24		3670	9.68	34.0	24		7190	18.7	43.1	23		12300	30.7	61.3
	960	16		3670	6.4	34.0	16		7190	12.4	43.1	15		12300	20.3	61.3
	725	12		3670	4.83	34.0	12		7190	9.36	43.1	11		12300	15.3	61.3
7 1 .	2900	41	70.45	3670	16.5	34.0	40	71.889	7190	31.6	43.1	39	74.616	12100	51.5	61.3
	1450	21		3670	8.25	34.0	20		7190	15.8	43.1	19		12100	25.7	61.3
	960	14		3670	5.46	34.0	13		7190	10.4	43.1	13		12100	17	61.3
	725	10		3670	4.12	34.0	10		7190	7.89	43.1	10		12100	12.9	61.3
8 0 .	2900	37	77.775	3670	15	34.0	35	82.832	7190	27.5	43.1	35	83.103	12100	46.3	61.3
	1450	19		3670	7.47	34.0	18		7190	13.7	43.1	17		12100	23.1	61.3
	960	12		3670	4.94	34.0	12		7190	9.08	43.1	12		12100	15.3	61.3
	725	9		3670	3.73	34.0	9		7190	6.85	43.1	9		12100	11.6	61.3
9 0 .	2900	34	84.887	3670	13.8	34.0	34	86.533	7190	26.3	43.1	32	89.893	12300	43.6	61.3
	1450	17		3670	6.86	34.0	17		7190	13.1	43.1	16		12300	21.8	61.3
	960	11		3670	4.54	34.0	11		7190	8.7	43.1	11		12300	14.4	61.3
	725	9		3670	3.43	34.0	8		7190	6.57	43.1	8		12300	10.9	61.3
1 0 0	2900	31	93.713	3670	12.5	34.0	29	99.705	7190	22.9	43.1	29	100.119	12300	39.2	61.3
	1450	15		3670	6.21	34.0	15		7190	11.4	43.1	14		12300	19.6	61.3
	960	10		3670	4.11	34.0	10		7190	7.56	43.1	10		12300	13	61.3
	725	8		3670	3.1	34.0	7		7190	5.71	43.1	7		12300	9.79	61.3
1 1 2	2900	27	106.992	3670	10.9	34.0	26	112.026	7190	20.4	43.1	25	113.789	12100	33.7	61.3
	1450	14		3670	5.44	34.0	13		7190	10.2	43.1	13		12100	16.9	61.3
	960	9		3670	3.6	34.0	9		7190	6.73	43.1	8		12100	11.2	61.3
	725	7		3670	2.72	34.0	6		7190	5.08	43.1	6		12100	8.43	61.3
1 2 5	2900	24	120.31	3670	9.72	34.0	24	120.359	7190	19	43.1	24	121.064	12100	31.7	61.3
	1450	12		3670	4.85	34.0	12		7190	9.48	43.1	12		12100	15.8	61.3
	960	8		3670	3.21	34.0	8		7190	6.27	43.1	8		12100	10.5	61.3
	725	6		3670	2.42	34.0	6		7190	4.74	43.1	6		12100	7.92	61.3
1 4 0	2900	22	128.917	3670	9.07	34.0	22	134.846	7190	17	43.1	21	137.087	12300	28.6	61.3
	1450	11		3670	4.53	34.0	11		7190	8.47	43.1	11		12300	14.3	61.3
	960	7		3670	2.99	34.0	7		7190	5.6	43.1	7		12300	9.44	61.3
	725	6		3670	2.26	34.0	5		7190	4.23	43.1	5		12300	7.13	61.3
1 6 0	2900	20	144.964	3670	8.09	34.0	20	144.876	7190	15.8	43.1	20	145.852	12300	26.8	61.3
	1450	10		3670	4.04	34.0	10		7190	7.89	43.1	10		12300	13.4	61.3
	960	7		3670	2.67	34.0	7		7190	5.22	43.1	7		12300	8.87	61.3
	725	5		3670	2.02	34.0	5		7190	3.94	43.1	5		12300	6.7	61.3

SERIES K

QUINTUPLE REDUCTION RATINGS

SIZES K03 - K05

0106

*P*_m - Input Power (kW) *N*₂ - Output Speed (rpm)
*M*₂ - Output Torque (Nm) *fra* - Overhung Load (kN)
i - Exact Ratio (:1)

QUINTUPLE REDUCTION

Column Entry			K0352				K0452				K0552							
6	7	8	Input Speed N1 (rpm)	N2 (rpm)	i (:1)	M2 (Nm)	Pm (kW)	fra (kN)	N2 (rpm)	i (:1)	M2 (Nm)	Pm (kW)	fra (kN)	N2 (rpm)	i (:1)	M2 (Nm)	Pm (kW)	fra (kN)
1	2	5	2900	22.69	128	225	0.56	6.00	21.58	134	440	1.05	6.00	24.49	118	660	1.78	7.50
			1450	11.35		225	0.28	6.00	10.79		440	0.52	6.00	12.25		660	0.89	7.50
			960	7.51		225	0.19	6.00	7.14		440	0.35	6.00	8.11		660	0.59	7.50
			725	5.63		225	0.14	6.00	5.36		440	0.26	6.00	6.08		660	0.44	7.50
1	4	0	2900	19.95	145	225	0.49	6.00	19.60	148	440	0.95	6.00	20.31	143	660	1.48	7.50
			1450	9.98		225	0.25	6.00	9.80		440	0.48	6.00	10.16		660	0.74	7.50
			960	6.60		225	0.16	6.00	6.49		440	0.31	6.00	6.72		660	0.49	7.50
			725	4.95		225	0.12	6.00	4.87		440	0.24	6.00	5.04		660	0.37	7.50
1	6	0	2900	17.61	165	225	0.44	6.00	17.04	170	440	0.83	6.00	18.43	157	660	1.34	7.50
			1450	8.81		225	0.22	6.00	8.52		440	0.41	6.00	9.22		660	0.67	7.50
			960	5.83		225	0.14	6.00	5.64		440	0.27	6.00	6.10		660	0.44	7.50
			725	4.37		225	0.11	6.00	4.23		440	0.21	6.00	4.58		660	0.33	7.50
2	0	0	2900	13.77	211	225	0.34	6.00	14.51	200	440	0.70	6.00	13.96	208	660	1.02	7.50
			1450	6.89		225	0.17	6.00	7.25		440	0.35	6.00	6.98		660	0.51	7.50
			960	4.56		225	0.11	6.00	4.80		440	0.23	6.00	4.62		660	0.34	7.50
			725	3.42		225	0.08	6.00	3.60		440	0.17	6.00	3.46		660	0.25	7.50
2	5	0	2900	12.78	227	225	0.32	6.00	11.26	258	440	0.55	6.00	10.99	264	660	0.80	7.50
			1450	6.39		225	0.16	6.00	5.63		440	0.27	6.00	5.49		660	0.40	7.50
			960	4.23		225	0.10	6.00	3.73		440	0.18	6.00	3.64		660	0.26	7.50
			725	3.17		225	0.079	6.00	2.80		440	0.14	6.00	2.73		660	0.20	7.50
2	8	0	2900	10.12	287	225	0.25	6.00	10.20	284	440	0.49	6.00	9.67	300	660	0.70	7.50
			1450	5.06		225	0.13	6.00	5.10		440	0.25	6.00	4.84		660	0.35	7.50
			960	3.35		225	0.083	6.00	3.38		440	0.16	6.00	3.20		660	0.23	7.50
			725	2.51		225	0.062	6.00	2.53		440	0.12	6.00	2.40		660	0.17	7.50
3	2	0	2900	8.93	325	225	0.22	6.00	9.00	322	440	0.44	6.00	9.17	316	660	0.67	7.50
			1450	4.46		225	0.11	6.00	4.50		440	0.22	6.00	4.58		660	0.33	7.50
			960	2.96		225	0.073	6.00	2.98		440	0.14	6.00	3.03		660	0.22	7.50
			725	2.22		225	0.055	6.00	2.23		440	0.11	6.00	2.28		660	0.17	7.50
3	6	0	2900	7.81	371	225	0.19	6.00	8.17	355	440	0.40	6.00	8.26	351	660	0.60	7.50
			1450	3.91		225	0.097	6.00	4.08		440	0.20	6.00	4.13		660	0.30	7.50
			960	2.59		225	0.064	6.00	2.70		440	0.13	6.00	2.74		660	0.20	7.50
			725	1.94		225	0.048	6.00	2.03		440	0.098	6.00	2.05		660	0.15	7.50
4	0	0	2900	7.02	413	225	0.17	6.00	7.12	407	440	0.35	6.00	7.27	399	660	0.53	7.50
			1450	3.51		225	0.087	6.00	3.56		440	0.17	6.00	3.64		660	0.26	7.50
			960	2.32		225	0.058	6.00	2.36		440	0.11	6.00	2.41		660	0.18	7.50
			725	1.74		225	0.043	6.00	1.77		440	0.086	6.00	1.81		660	0.13	7.50
4	5	0	2900	6.37	455	225	0.16	6.00	6.47	448	440	0.31	6.00	6.40	453	660	0.47	7.50
			1450	3.19		225	0.079	6.00	3.23		440	0.16	6.00	3.20		660	0.23	7.50
			960	2.11		225	0.052	6.00	2.14		440	0.104	6.00	2.12		660	0.15	7.50
			725	1.58		225	0.039	6.00	1.61		440	0.078	6.00	1.59		660	0.12	7.50
5	0	0	2900	5.62	516	225	0.14	6.00	5.71	508	440	0.28	6.00	5.81	499	660	0.42	7.50
			1450	2.81		225	0.070	6.00	2.85		440	0.14	6.00	2.91		660	0.21	7.50
			960	1.86		225	0.046	6.00	1.89		440	0.092	6.00	1.92		660	0.14	7.50
			725	1.40		225	0.035	6.00	1.42		440	0.069	6.00	1.44		660	0.11	7.50
5	6	0	2900	5.11	568	225	0.13	6.00	4.99	581	440	0.24	6.00	5.05	574	660	0.37	7.50
			1450	2.55		225	0.063	6.00	2.50		440	0.12	6.00	2.53		660	0.18	7.50
			960	1.69		225	0.042	6.00	1.65		440	0.080	6.00	1.67		660	0.12	7.50
			725	1.27		225	0.031	6.00	1.24		440	0.060	6.00	1.25		660	0.09	7.50
6	3	0	2900	4.47	649	225	0.11	6.00	4.49	646	440	0.22	6.00	4.65	624	660	0.34	7.50
			1450	2.23		225	0.055	6.00	2.24		440	0.11	6.00	2.32		660	0.17	7.50
			960	1.48		225	0.037	6.00	1.49		440	0.072	6.00	1.54		660	0.11	7.50
			725	1.11		225	0.028	6.00	1.11		440	0.054	6.00	1.15		660	0.084	7.50
7	0	0	2900	4.12	704	225	0.10	6.00	4.07	712	440	0.20	6.00	4.00	725	660	0.29	7.50
			1450	2.06		225	0.051	6.00	2.04		440	0.10	6.00	2.00		660	0.15	7.50
			960	1.36		225	0.034	6.00	1.35		440	0.065	6.00	1.32		660	0.096	7.50
			725	1.02		225	0.025	6.00	1.01		440	0.049	6.00	0.99		660	0.072	7.50
8	0	0	2900	3.63	798	225	0.090	6.00	3.59	808	440	0.17	6.00	3.57	812	660	0.26	7.50
			1450	1.82		225	0.045	6.00	1.80		440	0.087	6.00	1.79		660	0.13	7.50
			960	1.20		225	0.030	6.00	1.19		440	0.058	6.00	1.18		660	0.086	7.50
			725	0.902		225	0.022	6.00	0.891		440	0.043	6.00	0.887		660	0.065	7.50
9	0	0	2900	3.18	912	225	0.079	6.00	3.26	891	440	0.16	6.00	3.23	899	660	0.23	7.50
			1450	1.59		225	0.039	6.00	1.63		440	0.079	6.00	1.61		660	0.12	7.50
			960	1.05		225	0.026	6.00	1.08		440	0.052	6.00	1.07		660	0.078	7.50
			725	0.789		225	0.020	6.00	0.808		440	0.039	6.00	0.801		660	0.058	7.50
1	0	c	2900	2.86	1015	225	0.071	6.00	2.90	1000	440	0.14	6.00	2.77	1045	660	0.20	7.50
			1450	1.43		225	0.035	6.00	1.45		440	0.070	6.00	1.39		660	0.10	7.50
			960	0.946		225	0.023	6.00	0.960		440	0.047	6.00	0.919		660	0.067	7.50
			725	0.709		225	0.018	6.00	0.720		440	0.035	6.00	0.689		660	0.050	7.50

SERIES K

QUINTUPLE REDUCTION RATINGS

SIZES K03 - K05

0106

*P*_m - Input Power (kW) *N*₂ - Output Speed (rpm)
*M*₂ - Output Torque (Nm) *fra* - Overhung Load (kN)
i - Exact Ratio (:1)

QUINTUPLE REDUCTION

Column Entry	Input Speed N1 (rpm)	K0352					K0452					K0552				
		N2 (rpm)	<i>i</i> (:1)	M2 (Nm)	P _m (kW)	<i>fra</i> (kN)	N2 (rpm)	<i>i</i> (:1)	M2 (Nm)	P _m (kW)	<i>fra</i> (kN)	N2 (rpm)	<i>i</i> (:1)	M2 (Nm)	P _m (kW)	<i>fra</i> (kN)
1 1 c	2900	2.59	1119	225	0.064	6.00	2.63	1102	440	0.13	6.00	2.48	1169	660	0.18	7.50
	1450	1.30		225	0.032	6.00	1.32		440	0.064	6.00	1.24		660	0.090	7.50
	960	0.858		225	0.021	6.00	0.871		440	0.042	6.00	0.821		660	0.060	7.50
	725	0.644		225	0.016	6.00	0.654		440	0.032	6.00	0.616		660	0.045	7.50
1 2 c	2900	2.45	1183	225	0.061	6.00	2.29	1267	440	0.11	6.00	2.36	1231	660	0.17	7.50
	1450	1.23		225	0.030	6.00	1.14		440	0.055	6.00	1.18		660	0.086	7.50
	960	0.812		225	0.020	6.00	0.758		440	0.037	6.00	0.780		660	0.057	7.50
	725	0.609		225	0.015	6.00	0.568		440	0.028	6.00	0.585		660	0.043	7.50
1 4 c	2900	2.04	1423	225	0.051	6.00	2.03	1427	440	0.099	6.00	1.96	1477	660	0.14	7.50
	1450	1.02		225	0.025	6.00	1.02		440	0.049	6.00	0.98		660	0.071	7.50
	960	0.675		225	0.017	6.00	0.673		440	0.033	6.00	0.650		660	0.047	7.50
	725	0.506		225	0.013	6.00	0.505		440	0.024	6.00	0.487		660	0.035	7.50
1 6 c	2900	1.83	1583	225	0.045	6.00	1.81	1606	440	0.088	6.00	1.84	1577	660	0.13	7.50
	1450	0.916		225	0.023	6.00	0.903		440	0.044	6.00	0.919		660	0.067	7.50
	960	0.607		225	0.015	6.00	0.598		440	0.029	6.00	0.609		660	0.044	7.50
	725	0.455		225	0.011	6.00	0.448		440	0.022	6.00	0.457		660	0.033	7.50
1 8 c	2900	1.61	1800	225	0.040	6.00	1.63	1784	440	0.079	6.00	1.63	1777	660	0.12	7.50
	1450	0.805		225	0.020	6.00	0.813		440	0.039	6.00	0.816		660	0.059	7.50
	960	0.533		225	0.013	6.00	0.538		440	0.026	6.00	0.540		660	0.039	7.50
	725	0.400		225	0.010	6.00	0.404		440	0.020	6.00	0.405		660	0.029	7.50
2 0 c	2900	1.45	2000	225	0.036	6.00	1.47	2250	440	0.071	6.00	1.48	1957	660	0.11	7.50
	1450	0.725		225	0.018	6.00	0.644		440	0.036	6.00	0.741		660	0.054	7.50
	960	0.480		225	0.012	6.00	0.427		440	0.024	6.00	0.491		660	0.036	7.50
	725	0.360		225	0.009	6.00	0.320		440	0.018	6.00	0.368		660	0.027	7.50
2 2 c	2900	1.29	2250	225	0.032	6.00	1.28	2265	440	0.062	6.00	1.32	2205	660	0.096	7.50
	1450	0.644		225	0.016	6.00	0.640		440	0.031	6.00	0.658		660	0.048	7.50
	960	0.427		225	0.011	6.00	0.424		440	0.021	6.00	0.435		660	0.032	7.50
	725	0.320		225	0.008	6.00	0.318		440	0.015	6.00	0.327		660	0.024	7.50
2 5 c	2900	1.12	2579	225	0.028	6.00	1.18	2463	440	0.057	6.00	1.13	2563	660	0.082	7.50
	1450	0.562		225	0.014	6.00	0.589		440	0.029	6.00	0.566		660	0.041	7.50
	960	0.372		225	0.009	6.00	0.390		440	0.019	6.00	0.375		660	0.027	7.50
	725	0.279		225	0.007	6.00	0.292		440	0.014	6.00	0.281		660	0.020	7.50
2 8 c	2900	1.07	2699	225	0.027	6.00	1.04	2799	440	0.050	6.00	1.02	2847	660	0.074	7.50
	1450	0.537		225	0.013	6.00	0.518		440	0.025	6.00	0.509		660	0.037	7.50
	960	0.356		225	0.009	6.00	0.343		440	0.017	6.00	0.337		660	0.025	7.50
	725	0.267		225	0.007	6.00	0.257		440	0.012	6.00	0.253		660	0.018	7.50
3 2 c	2900	0.937	3094	225	0.023	6.00	0.863	3360	440	0.042	6.00	0.876	3310	660	0.064	7.50
	1450	0.469		225	0.012	6.00	0.432		440	0.021	6.00	0.438		660	0.032	7.50
	960	0.310		225	0.008	6.00	0.286		440	0.014	6.00	0.290		660	0.021	7.50
	725	0.233		225	0.006	6.00	0.214		440	0.010	6.00	0.218		660	0.016	7.50
3 6 c	2900	0.825	3516	225	0.020	6.00	0.817	3548	440	0.040	6.00	0.772	3757	660	0.056	7.50
	1450	0.412		225	0.010	6.00	0.409		440	0.020	6.00	0.386		660	0.028	7.50
	960	0.273		225	0.007	6.00	0.271		440	0.013	6.00	0.256		660	0.019	7.50
	725	0.205		225	0.005	6.00	0.203		440	0.010	6.00	0.192		660	0.014	7.50
4 0 c	2900	0.724	4007	225	0.018	6.00	0.725	3998	440	0.035	6.00	0.715	4056	660	0.052	7.50
	1450	0.362		225	0.009	6.00	0.363		440	0.018	6.00	0.357		660	0.026	7.50
	960	0.240		225	0.006	6.00	0.240		440	0.012	6.00	0.237		660	0.017	7.50
	725	0.180		225	0.004	6.00	0.180		440	0.009	6.00	0.178		660	0.013	7.50
4 5 c	2900	0.637	4554	225	0.016	6.00	0.638	4543	440	0.031	6.00	0.630	4604	660	0.046	7.50
	1450	0.318		225	0.008	6.00	0.319		440	0.015	6.00	0.315		660	0.023	7.50
	960	0.211		225	0.005	6.00	0.211		440	0.010	6.00	0.209		660	0.015	7.50
	725	0.158		225	0.004	6.00	0.158		440	0.008	6.00	0.156		660	0.011	7.50
5 0 c	2900	0.601	4826	187	0.012	6.00	0.624	4647	440	0.030	6.00	0.565	5131	660	0.041	7.50
	1450	0.300		187	0.006	6.00	0.312		440	0.015	6.00	0.283		660	0.021	7.50
	960	0.199		187	0.004	6.00	0.207		440	0.010	6.00	0.187		660	0.014	7.50
	725	0.149		187	0.003	6.00	0.155		440	0.008	6.00	0.140		660	0.010	7.50
5 6 c	2900	0.529	5485	187	0.011	6.00	0.549	5281	440	0.027	6.00	0.554	5234	660	0.040	7.50
	1450	0.264		187	0.005	6.00	0.275		440	0.013	6.00	0.277		660	0.020	7.50
	960	0.175		187	0.004	6.00	0.182		440	0.009	6.00	0.183		660	0.013	7.50
	725	0.131		187	0.003	6.00	0.136		440	0.007	6.00	0.138		660	0.010	7.50
6 3 c	2900	0.461	6286	160	0.008	6.00	0.484	5994	440	0.023	6.00	0.497	5833	660	0.036	7.50
	1450	0.231		160	0.004	6.00	0.242		440	0.012	6.00	0.249		660	0.018	7.50
	960	0.153		160	0.003	6.00	0.160		440	0.008	6.00	0.165		660	0.012	7.50
	725	0.115		160	0.002	6.00	0.120		440	0.006	6.00	0.123		660	0.009	7.50
7 1 c	2900	0.406	7144	158	0.007	6.00	0.426	6815	440	0.021	6.00	0.443	6542	605	0.030	7.50
	1450	0.203		158	0.004	6.00	0.213		440	0.010	6.00	0.222		605	0.015	7.50
	960	0.134		158	0.002	6.00	0.141		440	0.007	6.00	0.147		605	0.010	7.50
	725	0.101		158	0.002	6.00	0.106		440	0.005	6.00	0.110		605	0.007	7.50

SERIES K

QUINTUPLE REDUCTION RATINGS

SIZES K06 - K08

0106

P_m - Input Power (kW) *N₂* - Output Speed (rpm)
M₂ - Output Torque (Nm) *fra* - Overhung Load (kN)
i - Exact Ratio (:1)

QUINTUPLE REDUCTION

Column Entry	Input Speed N1 (rpm)	K0652					K0752					K0852				
		N2 (rpm)	i (:1)	M2 (Nm)	Pm (kW)	fra (kN)	N2 (rpm)	i (:1)	M2 (Nm)	Pm (kW)	fra (kN)	N2 (rpm)	i (:1)	M2 (Nm)	Pm (kW)	fra (kN)
1 2 5	2900	24.96	116	825	2.27	8.00	24.11	120	1600	4.25	15.0	21.94	132	2710	6.55	15.7
	1450	12.48		825	1.13	8.00	12.05		1600	2.13	15.0	10.97		2710	3.28	15.7
	960	8.26		825	0.75	8.00	7.98		1600	1.41	15.0	7.26		2710	2.17	15.7
	725	6.20		825	0.56	8.00	5.99		1600	1.06	15.0	5.45		2710	1.63	15.7
1 4 0	2900	20.70	140	825	1.88	8.00	21.73	133	1600	3.83	15.0	20.05	145	2710	5.99	15.7
	1450	10.35		825	0.94	8.00	10.86		1600	1.92	15.0	10.02		2710	2.99	15.7
	960	6.85		825	0.62	8.00	7.19		1600	1.27	15.0	6.64		2710	1.98	15.7
	725	5.14		825	0.47	8.00	5.39		1600	0.95	15.0	4.98		2710	1.49	15.7
1 6 0	2900	18.78	154	825	1.71	8.00	19.72	147	1600	3.48	15.0	17.72	164	2710	5.29	15.7
	1450	9.39		825	0.85	8.00	9.86		1600	1.74	15.0	8.86		2710	2.65	15.7
	960	6.22		825	0.57	8.00	6.53		1600	1.15	15.0	5.87		2710	1.75	15.7
	725	4.66		825	0.42	8.00	4.90		1600	0.86	15.0	4.40		2710	1.31	15.7
2 0 0	2900	14.22	204	825	1.29	8.00	13.74	211	1600	2.42	15.0	14.26	203	2420	3.80	15.7
	1450	7.11		825	0.65	8.00	6.87		1600	1.21	15.0	7.13		2420	1.90	15.7
	960	4.71		825	0.43	8.00	4.55		1600	0.80	15.0	4.72		2420	1.26	15.7
	725	3.53		825	0.32	8.00	3.41		1600	0.60	15.0	3.54		2420	0.94	15.7
2 5 0	2900	11.20	259	825	1.02	8.00	12.43	233	1600	2.19	15.0	12.72	228	2710	3.80	15.7
	1450	5.60		825	0.51	8.00	6.21		1600	1.10	15.0	6.36		2710	1.90	15.7
	960	3.71		825	0.34	8.00	4.11		1600	0.73	15.0	4.21		2710	1.26	15.7
	725	2.78		825	0.25	8.00	3.09		1600	0.54	15.0	3.16		2710	0.94	15.7
2 8 0	2900	9.86	294	825	0.90	8.00	10.94	265	1600	1.93	15.0	10.82	268	2710	3.23	15.7
	1450	4.93		825	0.45	8.00	5.47		1600	0.96	15.0	5.41		2710	1.62	15.7
	960	3.26		825	0.30	8.00	3.62		1600	0.64	15.0	3.58		2710	1.07	15.7
	725	2.45		825	0.22	8.00	2.72		1600	0.48	15.0	2.69		2710	0.80	15.7
3 2 0	2900	9.34	310	825	0.85	8.00	9.52	305	1600	1.68	15.0	9.77	297	2710	2.92	15.7
	1450	4.67		825	0.42	8.00	4.76		1600	0.84	15.0	4.88		2710	1.46	15.7
	960	3.09		825	0.28	8.00	3.15		1600	0.56	15.0	3.23		2710	0.97	15.7
	725	2.32		825	0.21	8.00	2.36		1600	0.42	15.0	2.42		2710	0.72	15.7
3 6 0	2900	8.42	344	825	0.77	8.00	7.76	374	1600	1.37	15.0	8.61	337	2710	2.57	15.7
	1450	4.21		825	0.38	8.00	3.88		1600	0.68	15.0	4.31		2710	1.29	15.7
	960	2.79		825	0.25	8.00	2.57		1600	0.45	15.0	2.85		2710	0.85	15.7
	725	2.09		825	0.19	8.00	1.93		1600	0.34	15.0	2.14		2710	0.64	15.7
4 0 0	2900	7.41	391	825	0.67	8.00	6.99	415	1650	1.27	15.0	7.22	401	2710	2.16	15.7
	1450	3.71		825	0.34	8.00	3.50		1650	0.64	15.0	3.61		2710	1.08	15.7
	960	2.45		825	0.22	8.00	2.32		1650	0.42	15.0	2.39		2710	0.71	15.7
	725	1.84		825	0.17	8.00	1.74		1650	0.32	15.0	1.79		2710	0.54	15.7
4 5 0	2900	6.52	445	825	0.59	8.00	6.23	466	1650	1.13	15.0	6.27	462	2710	1.87	15.7
	1450	3.26		825	0.30	8.00	3.11		1650	0.57	15.0	3.14		2710	0.94	15.7
	960	2.16		825	0.20	8.00	2.06		1650	0.37	15.0	2.08		2710	0.62	15.7
	725	1.59		825	0.15	8.00	1.55		1650	0.28	15.0	1.56		2710	0.47	15.7
5 0 0	2900	5.92	489	825	0.54	8.00	5.65	513	1650	1.03	15.0	5.73	506	2710	1.71	15.7
	1450	2.96		825	0.27	8.00	2.83		1650	0.51	15.0	2.87		2710	0.86	15.7
	960	1.96		825	0.18	8.00	1.87		1650	0.34	15.0	1.90		2710	0.57	15.7
	725	1.47		825	0.13	8.00	1.40		1650	0.26	15.0	1.42		2710	0.43	15.7
5 6 0	2900	5.15	563	825	0.47	8.00	4.92	590	1650	0.89	15.0	5.39	538	2710	1.61	15.7
	1450	2.58		825	0.23	8.00	2.46		1650	0.45	15.0	2.70		2710	0.81	15.7
	960	1.71		825	0.16	8.00	1.63		1650	0.30	15.0	1.79		2710	0.53	15.7
	725	1.28		825	0.12	8.00	1.22		1650	0.22	15.0	1.34		2710	0.40	15.7
6 3 0	2900	4.74	612	825	0.43	8.00	4.52	641	1650	0.82	15.0	4.52	641	2710	1.35	15.7
	1450	2.37		825	0.22	8.00	2.26		1650	0.41	15.0	2.26		2710	0.68	15.7
	960	1.57		825	0.14	8.00	1.50		1650	0.27	15.0	1.50		2710	0.45	15.7
	725	1.18		825	0.11	8.00	1.12		1650	0.20	15.0	1.12		2710	0.34	15.7
7 0 0	2900	4.07	712	825	0.37	8.00	3.93	737	1650	0.72	15.0	3.82	760	2710	1.14	15.7
	1450	2.04		825	0.19	8.00	1.97		1650	0.36	15.0	1.91		2710	0.57	15.7
	960	1.35		825	0.12	8.00	1.30		1650	0.24	15.0	1.26		2710	0.38	15.7
	725	1.01		825	0.092	8.00	0.98		1650	0.18	15.0	0.95		2710	0.28	15.7
8 0 0	2900	3.64	797	825	0.33	8.00	3.47	836	1650	0.63	15.0	3.57	811	2710	1.07	15.7
	1450	1.82		825	0.17	8.00	1.73		1650	0.32	15.0	1.79		2710	0.53	15.7
	960	1.21		825	0.11	8.00	1.15		1650	0.21	15.0	1.18		2710	0.35	15.7
	725	0.904		825	0.082	8.00	0.861		1650	0.16	15.0	0.887		2710	0.27	15.7
9 0 0	2900	3.29	882	825	0.30	8.00	3.14	924	1650	0.57	15.0	3.27	888	2710	0.98	15.7
	1450	1.64		825	0.15	8.00	1.57		1650	0.29	15.0	1.63		2710	0.49	15.7
	960	1.09		825	0.099	8.00	1.04		1650	0.19	15.0	1.08		2710	0.32	15.7
	725	0.816		825	0.074	8.00	0.779		1650	0.14	15.0	0.811		2710	0.24	15.7
1 0 c	2900	2.83	1026	825	0.26	8.00	2.73	1062	1650	0.50	15.0	2.88	1007	2710	0.86	15.7
	1450	1.41		825	0.13	8.00	1.37		1650	0.25	15.0	1.44		2710	0.43	15.7
	960	0.936		825	0.085	8.00	0.904		1650	0.16	15.0	0.954		2710	0.28	15.7
	725	0.702		825	0.064	8.00	0.678		1650	0.12	15.0	0.715		2710	0.21	15.7

**QUINTUPLE REDUCTION RATINGS
SIZES K06 - K08**

0106

*P*_m - Input Power (kW) *N*₂ - Output Speed (rpm)
*M*₂ - Output Torque (Nm) *fra* - Overhung Load (kN)
i - Exact Ratio (:1)

QUINTUPLE REDUCTION

Column Entry			K0652				K0752				K0852							
6	7	8	Input Speed N1 (rpm)	N2 (rpm)	i (:1)	M2 (Nm)	Pm (kW)	fra (kN)	N2 (rpm)	i (:1)	M2 (Nm)	Pm (kW)	fra (kN)	N2 (rpm)	i (:1)	M2 (Nm)	Pm (kW)	fra (kN)
1	1	c	2900	2.53	1147	825	0.23	8.00	2.41	1204	1650	0.44	15.0	2.63	1102	2710	0.79	15.7
			1450	1.26		825	0.11	8.00	1.20		1650	0.22	15.0	1.32		2710	0.39	15.7
			960	0.837		825	0.076	8.00	0.797		1650	0.15	15.0	0.871		2710	0.26	15.7
			725	0.627		825	0.057	8.00	0.598		1650	0.11	15.0	0.654		2710	0.20	15.7
1	2	c	2900	2.40	1208	825	0.22	8.00	2.29	1267	1650	0.42	15.0	2.33	1246	2710	0.69	15.7
			1450	1.20		825	0.11	8.00	1.14		1650	0.21	15.0	1.16		2710	0.35	15.7
			960	0.795		825	0.072	8.00	0.757		1650	0.14	15.0	0.770		2710	0.23	15.7
			725	0.596		825	0.054	8.00	0.568		1650	0.10	15.0	0.578		2710	0.17	15.7
1	4	c	2900	2.00	1449	825	0.18	8.00	1.91	1521	1650	0.35	15.0	1.97	1470	2710	0.59	15.7
			1450	1.00		825	0.091	8.00	0.95		1650	0.17	15.0	0.99		2710	0.29	15.7
			960	0.662		825	0.060	8.00	0.631		1650	0.11	15.0	0.653		2710	0.20	15.7
			725	0.497		825	0.045	8.00	0.473		1650	0.086	15.0	0.490		2710	0.15	15.7
1	6	c	2900	1.87	1548	825	0.17	8.00	1.69	1720	1650	0.31	15.0	1.75	1659	2710	0.52	15.7
			1450	0.937		825	0.085	8.00	0.843		1650	0.15	15.0	0.874		2710	0.26	15.7
			960	0.620		825	0.056	8.00	0.558		1650	0.10	15.0	0.579		2710	0.17	15.7
			725	0.465		825	0.042	8.00	0.419		1650	0.076	15.0	0.434		2710	0.13	15.7
1	8	c	2900	1.66	1744	825	0.15	8.00	1.50	1938	1650	0.27	15.0	1.60	1817	2710	0.48	15.7
			1450	0.832		825	0.076	8.00	0.748		1650	0.14	15.0	0.798		2710	0.24	15.7
			960	0.551		825	0.050	8.00	0.495		1650	0.090	15.0	0.528		2710	0.16	15.7
			725	0.413		825	0.038	8.00	0.372		1650	0.068	15.0	0.396		2710	0.12	15.7
2	0	c	2900	1.51	1920	825	0.14	8.00	1.45	1994	1650	0.26	15.0	1.44	2011	2710	0.43	15.7
			1450	0.755		825	0.069	8.00	0.727		1650	0.13	15.0	0.721		2710	0.22	15.7
			960	0.500		825	0.045	8.00	0.482		1650	0.088	15.0	0.477		2710	0.14	15.7
			725	0.375		825	0.034	8.00	0.361		1650	0.066	15.0	0.358		2710	0.11	15.7
2	2	c	2900	1.34	2164	825	0.12	8.00	1.29	2246	1650	0.23	15.0	1.32	2202	2710	0.39	15.7
			1450	0.670		825	0.061	8.00	0.645		1650	0.12	15.0	0.658		2710	0.20	15.7
			960	0.444		825	0.040	8.00	0.427		1650	0.078	15.0	0.436		2710	0.13	15.7
			725	0.333		825	0.030	8.00	0.321		1650	0.058	15.0	0.327		2710	0.098	15.7
2	5	c	2900	1.15	2515	825	0.10	8.00	1.11	2611	1650	0.20	15.0	1.07	2699	2710	0.32	15.7
			1450	0.576		825	0.052	8.00	0.555		1650	0.10	15.0	0.537		2710	0.16	15.7
			960	0.382		825	0.035	8.00	0.368		1650	0.067	15.0	0.356		2710	0.11	15.7
			725	0.286		825	0.026	8.00	0.276		1650	0.050	15.0	0.267		2710	0.080	15.7
2	8	c	2900	1.04	2794	825	0.094	8.00	0.99	2934	1650	0.18	15.0	1.03	2821	2710	0.31	15.7
			1450	0.519		825	0.047	8.00	0.494		1650	0.090	15.0	0.514		2710	0.15	15.7
			960	0.344		825	0.031	8.00	0.327		1650	0.060	15.0	0.340		2710	0.10	15.7
			725	0.258		825	0.023	8.00	0.245		1650	0.045	15.0	0.255		2710	0.076	15.7
3	2	c	2900	0.893	3248	825	0.081	8.00	0.850	3411	1650	0.15	15.0	0.921	3147	2710	0.28	15.7
			1450	0.446		825	0.041	8.00	0.425		1650	0.077	15.0	0.461		2710	0.14	15.7
			960	0.296		825	0.027	8.00	0.281		1650	0.051	15.0	0.305		2710	0.091	15.7
			725	0.222		825	0.020	8.00	0.211		1650	0.038	15.0	0.229		2710	0.068	15.7
3	6	c	2900	0.787	3686	825	0.072	8.00	0.749	3871	1650	0.14	15.0	0.753	3853	2710	0.22	15.7
			1450	0.393		825	0.036	8.00	0.375		1650	0.068	15.0	0.376		2710	0.11	15.7
			960	0.260		825	0.024	8.00	0.248		1650	0.045	15.0	0.249		2710	0.074	15.7
			725	0.195		825	0.018	8.00	0.186		1650	0.034	15.0	0.187		2710	0.056	15.7
4	0	c	2900	0.729	3981	825	0.066	8.00	0.709	4093	1650	0.13	15.0	0.684	4237	2710	0.20	15.7
			1450	0.364		825	0.033	8.00	0.354		1650	0.064	15.0	0.342		2710	0.10	15.7
			960	0.241		825	0.022	8.00	0.235		1650	0.043	15.0	0.227		2710	0.068	15.7
			725	0.181		825	0.016	8.00	0.176		1650	0.032	15.0	0.170		2710	0.051	15.7
4	5	c	2900	0.642	4518	825	0.058	8.00	0.624	4646	1650	0.11	15.0	0.614	4722	2710	0.18	15.7
			1450	0.321		825	0.029	8.00	0.312		1650	0.057	15.0	0.307		2710	0.092	15.7
			960	0.212		825	0.019	8.00	0.207		1650	0.038	15.0	0.203		2710	0.061	15.7
			725	0.159		825	0.014	8.00	0.155		1650	0.028	15.0	0.152		2710	0.046	15.7
5	0	c	2900	0.576	5036	825	0.052	8.00	0.549	5281	1650	0.10	15.0	0.562	5157	2710	0.17	15.7
			1450	0.288		825	0.026	8.00	0.275		1650	0.050	15.0	0.281		2710	0.084	15.7
			960	0.191		825	0.017	8.00	0.182		1650	0.033	15.0	0.186		2710	0.056	15.7
			725	0.143		825	0.013	8.00	0.136		1650	0.025	15.0	0.140		2710	0.042	15.7
5	6	c	2900	0.565	5136	825	0.051	8.00	0.543	5345	1650	0.10	15.0	0.548	5296	2710	0.16	15.7
			1450	0.282		825	0.026	8.00	0.271		1650	0.049	15.0	0.274		2710	0.082	15.7
			960	0.187		825	0.017	8.00	0.180		1650	0.033	15.0	0.181		2710	0.054	15.7
			725	0.140		825	0.013	8.00	0.135		1650	0.024	15.0	0.136		2710	0.041	15.7
6	3	c	2900	0.507	5725	825	0.046	8.00	0.477	6076	1650	0.087	15.0	0.501	5783	2710	0.15	15.7
			1450	0.253		825	0.023	8.00	0.239		1650	0.043	15.0	0.251		2710	0.075	15.7
			960	0.168		825	0.015	8.00	0.158		1650	0.029	15.0	0.166		2710	0.050	15.7
			725	0.126		825	0.011	8.00	0.118		1650	0.022	15.0	0.124		2710	0.037	15.7
7	1	c	2900	0.452	6420	605	0.030	8.00	0.430	6752	1360	0.064	15.0	0.435	6660	2710	0.13	15.7
			1450	0.226		605	0.015	8.00	0.215		1360	0.032	15.0	0.218		2710	0.065	15.7
			960	0.150		605	0.010	8.00	0.142		1360	0.021	15.0	0.144		2710	0.043	15.7
			725	0.112		605	0.007	8.00	0.107		1360	0.016	15.0	0.108		2710	0.032	15.7

**QUINTUPLE REDUCTION RATINGS
SIZES K09 - K12**

0106

*P*_m - Input Power (kW) *N*₂ - Output Speed (rpm)
*M*₂ - Output Torque (Nm) *fra* - Overhung Load (kN)
i - Exact Ratio (:1)

QUINTUPLE REDUCTION

Column Entry	Input Speed N1 (rpm)	K0951					K1051					K1251				
		N2 (rpm)	<i>i</i> (:1)	<i>M</i> ₂ (Nm)	<i>P</i> _m (kW)	<i>fra</i> (kN)	N2 (rpm)	<i>i</i> (:1)	<i>M</i> ₂ (Nm)	<i>P</i> _m (kW)	<i>fra</i> (kN)	N2 (rpm)	<i>i</i> (:1)	<i>M</i> ₂ (Nm)	<i>P</i> _m (kW)	<i>fra</i> (kN)
1 2 5	2900															
	1450															
	960															
	725															
1 4 0	2900															
	1450															
	960															
	725															
1 6 0	2900	18.02	161	4110	8.16	34.0	17.38	167	7250	13.89	43.1	16.85	172	12100	22.47	61.3
	1450	9.01		4110	4.08	34.0	8.69		7250	6.94	43.1	8.42		12100	11.23	61.3
	960	5.97		4110	2.70	34.0	5.75		7250	4.60	43.1	5.58		12100	7.44	61.3
	725	4.47		4110	2.03	34.0	4.32		7250	3.45	43.1	4.18		12100	5.58	61.3
2 0 0	2900	12.82	226	4300	6.07	34.0	12.82	226	7250	10.03	43.1	10.79	269	12100	14.39	61.3
	1450	6.41		4300	3.04	34.0	6.41		7250	5.01	43.1	5.39		12100	7.19	61.3
	960	4.24		4300	2.01	34.0	4.24		7250	3.32	43.1	3.57		12100	4.76	61.3
	725	3.18		4300	1.51	34.0	3.18		7250	2.49	43.1	2.68		12100	3.57	61.3
2 5 0	2900	11.44	254	4110	5.18	34.0	11.17	260	7250	8.93	43.1	12.16	238	12100	16.22	61.3
	1450	5.72		4110	2.59	34.0	5.59		7250	4.46	43.1	6.08		12100	8.11	61.3
	960	3.79		4110	1.71	34.0	3.70		7250	2.96	43.1	4.03		12100	5.37	61.3
	725	2.84		4110	1.29	34.0	2.77		7250	2.22	43.1	3.02		12100	4.03	61.3
2 8 0	2900	10.29	282	4300	4.88	34.0	10.16	285	7250	8.12	43.1	9.60	302	12100	12.81	61.3
	1450	5.15		4300	2.44	34.0	5.08		7250	4.06	43.1	4.80		12100	6.40	61.3
	960	3.41		4300	1.61	34.0	3.36		7250	2.69	43.1	3.18		12100	4.24	61.3
	725	2.56		4300	1.21	34.0	2.52		7250	2.02	43.1	2.38		12100	3.18	61.3
3 2 0	2900	9.72	298	4300	4.61	34.0	9.14	317	7250	7.31	43.1	8.74	332	12100	11.65	61.3
	1450	4.86		4300	2.30	34.0	4.57		7250	3.65	43.1	4.37		12100	5.83	61.3
	960	3.22		4300	1.53	34.0	3.03		7250	2.42	43.1	2.89		12100	3.86	61.3
	725	2.41		4300	1.14	34.0	2.27		7250	1.81	43.1	2.17		12100	2.89	61.3
3 6 0	2900	8.75	331	4110	3.97	34.0	7.78	373	7250	6.22	43.1	7.54	385	12100	10.05	61.3
	1450	4.38		4110	1.98	34.0	3.89		7250	3.11	43.1	3.77		12100	5.03	61.3
	960	2.90		4110	1.31	34.0	2.57		7250	2.06	43.1	2.50		12100	3.33	61.3
	725	2.17		4110	0.98	34.0	1.93		7250	1.54	43.1	1.87		12100	2.50	61.3
4 0 0	2900	7.22	402	4110	3.27	34.0	7.00	414	7250	5.59	43.1	6.63	437	12100	8.84	61.3
	1450	3.61		4110	1.64	34.0	3.50		7250	2.80	43.1	3.32		12100	4.42	61.3
	960	2.39		4110	1.08	34.0	2.32		7250	1.85	43.1	2.19		12100	2.93	61.3
	725	1.79		4110	0.81	34.0	1.74		7250	1.39	43.1	1.65		12100	2.20	61.3
4 5 0	2900	6.37	455	4300	3.02	34.0	6.16	471	7250	4.92	43.1	5.88	493	12100	7.84	61.3
	1450	3.18		4300	1.51	34.0	3.08		7250	2.46	43.1	2.94		12100	3.92	61.3
	960	2.11		4300	1.00	34.0	2.04		7250	1.63	43.1	1.95		12100	2.60	61.3
	725	1.58		4300	0.75	34.0	1.53		7250	1.22	43.1	1.46		12100	1.95	61.3
5 0 0	2900	5.93	489	4300	2.81	34.0	5.63	515	7250	4.50	43.1	5.46	531	12100	7.28	61.3
	1450	2.97		4300	1.41	34.0	2.82		7250	2.25	43.1	2.73		12100	3.64	61.3
	960	1.96		4300	0.93	34.0	1.87		7250	1.49	43.1	1.81		12100	2.41	61.3
	725	1.47		4300	0.70	34.0	1.40		7250	1.12	43.1	1.36		12100	1.81	61.3
5 6 0	2900	5.15	563	4110	2.33	34.0	5.12	566	7250	4.09	43.1	4.96	584	12100	6.62	61.3
	1450	2.58		4110	1.17	34.0	2.56		7250	2.05	43.1	2.48		12100	3.31	61.3
	960	1.71		4110	0.77	34.0	1.70		7250	1.35	43.1	1.64		12100	2.19	61.3
	725	1.28		4110	0.58	34.0	1.27		7250	1.02	43.1	1.23		12100	1.64	61.3
6 3 0	2900	4.43	655	4110	2.01	34.0	4.46	651	7250	3.56	43.1	4.32	671	12100	5.76	61.3
	1450	2.22		4110	1.00	34.0	2.23		7250	1.78	43.1	2.16		12100	2.88	61.3
	960	1.47		4110	0.66	34.0	1.48		7250	1.18	43.1	1.43		12100	1.91	61.3
	725	1.10		4110	0.50	34.0	1.11		7250	0.88	43.1	1.07		12100	1.43	61.3
7 0 0	2900	3.99	727	4110	1.81	34.0	4.01	723	7250	3.21	43.1	3.83	757	12100	5.11	61.3
	1450	1.99		4110	0.90	34.0	2.01		7250	1.60	43.1	1.92		12100	2.56	61.3
	960	1.32		4110	0.60	34.0	1.33		7250	1.06	43.1	1.27		12100	1.69	61.3
	725	0.99		4110	0.45	34.0	1.00		7250	0.80	43.1	0.95		12100	1.27	61.3
8 0 0	2900	3.68	789	4300	1.74	34.0	3.70	783	7250	2.96	43.1	3.59	809	12300	4.86	61.3
	1450	1.84		4300	0.87	34.0	1.85		7250	1.48	43.1	1.79		12300	2.43	61.3
	960	1.22		4300	0.58	34.0	1.23		7250	0.98	43.1	1.19		12300	1.61	61.3
	725	0.913		4300	0.43	34.0	0.919		7250	0.73	43.1	0.890		12300	1.21	61.3
9 0 0	2900	3.08	940	4300	1.46	34.0	3.21	904	7250	2.56	43.1	3.06	946	12100	4.09	61.3
	1450	1.54		4300	0.73	34.0	1.60		7250	1.28	43.1	1.53		12100	2.04	61.3
	960	1.02		4300	0.48	34.0	1.06		7250	0.85	43.1	1.01		12100	1.35	61.3
	725	0.766		4300	0.36	34.0	0.796		7250	0.64	43.1	0.761		12100	1.01	61.3
1 0 c	2900	2.82	1028	4110	1.28	34.0	2.96	980	7250	2.37	43.1	2.87	1012	12300	3.89	61.3
	1450	1.41		4110	0.64	34.0	1.48		7250	1.18	43.1	1.43		12300	1.94	61.3
	960	0.934		4110	0.42	34.0	0.980		7250	0.78	43.1	0.949		12300	1.29	61.3
	725	0.701		4110	0.32	34.0	0.735		7250	0.59	43.1	0.712		12300	0.96	61.3

**QUINTUPLE REDUCTION RATINGS
SIZES K09 - K12**

0106

*P*_m - Input Power (kW) *N*₂ - Output Speed (rpm)
*M*₂ - Output Torque (Nm) *fra* - Overhung Load (kN)
i - Exact Ratio (:1)

QUINTUPLE REDUCTION

Column Entry	Input Speed N1 (rpm)	K0951					K1051					K1251				
		N2 (rpm)	i (:1)	M2 (Nm)	P _m (kW)	fra (kN)	N2 (rpm)	i (:1)	M2 (Nm)	P _m (kW)	fra (kN)	N2 (rpm)	i (:1)	M2 (Nm)	P _m (kW)	fra (kN)
1 1 c	2900	2.60	1115	4300	1.23	34.0	2.48	1171	7250	1.98	43.1	2.54	1140	12300	3.45	61.3
	1450	1.30		4300	0.62	34.0	1.24		7250	0.99	43.1	1.27		12300	1.72	61.3
	960	0.861		4300	0.41	34.0	0.820		7250	0.66	43.1	0.842		12300	1.14	61.3
	725	0.646		4300	0.31	34.0	0.615		7250	0.49	43.1	0.631		12300	0.86	61.3
1 2 c	2900	2.44	1190	4300	1.16	34.0	2.29	1268	7250	1.83	43.1	2.37	1226	12100	3.16	61.3
	1450	1.22		4300	0.58	34.0	1.14		7250	0.91	43.1	1.18		12100	1.58	61.3
	960	0.807		4300	0.38	34.0	0.757		7250	0.60	43.1	0.783		12100	1.04	61.3
	725	0.605		4300	0.29	34.0	0.568		7250	0.45	43.1	0.588		12100	0.78	61.3
1 4 c	2900	1.96	1477	4300	0.93	34.0	1.97	1470	7250	1.58	43.1	1.91	1519	12300	2.59	61.3
	1450	0.98		4300	0.47	34.0	0.99		7250	0.79	43.1	0.95		12300	1.29	61.3
	960	0.650		4300	0.31	34.0	0.653		7250	0.52	43.1	0.632		12300	0.86	61.3
	725	0.488		4300	0.23	34.0	0.490		7250	0.39	43.1	0.474		12300	0.64	61.3
1 6 c	2900	1.77	1641	4300	0.84	34.0	1.77	1634	7250	1.42	43.1	1.69	1712	12300	2.30	61.3
	1450	0.884		4300	0.42	34.0	0.887		7250	0.71	43.1	0.847		12300	1.15	61.3
	960	0.585		4300	0.28	34.0	0.588		7250	0.47	43.1	0.561		12300	0.76	61.3
	725	0.439		4300	0.21	34.0	0.441		7250	0.35	43.1	0.421		12300	0.57	61.3
1 8 c	2900	1.67	1741	4300	0.79	34.0	1.65	1754	7250	1.32	43.1	1.60	1811	12300	2.17	61.3
	1450	0.833		4300	0.39	34.0	0.827		7250	0.66	43.1	0.801		12300	1.09	61.3
	960	0.551		4300	0.26	34.0	0.547		7250	0.44	43.1	0.530		12300	0.72	61.3
	725	0.413		4300	0.20	34.0	0.411		7250	0.33	43.1	0.398		12300	0.54	61.3
2 0 c	2900	1.50	1935	4300	0.71	34.0	1.49	1949	7250	1.19	43.1	1.42	2042	12300	1.93	61.3
	1450	0.750		4300	0.36	34.0	0.744		7250	0.59	43.1	0.710		12300	0.96	61.3
	960	0.496		4300	0.24	34.0	0.493		7250	0.39	43.1	0.470		12300	0.64	61.3
	725	0.372		4300	0.18	34.0	0.369		7250	0.30	43.1	0.353		12300	0.48	61.3
2 2 c	2900	1.37	2118	4300	0.65	34.0	1.36	2134	7250	1.09	43.1	1.30	2236	12300	1.76	61.3
	1450	0.684		4300	0.32	34.0	0.679		7250	0.54	43.1	0.649		12300	0.88	61.3
	960	0.453		4300	0.21	34.0	0.450		7250	0.36	43.1	0.429		12300	0.58	61.3
	725	0.340		4300	0.16	34.0	0.337		7250	0.27	43.1	0.322		12300	0.44	61.3
2 5 c	2900	1.12	2596	4300	0.53	34.0	1.13	2561	7250	0.90	43.1	1.08	2683	12300	1.47	61.3
	1450	0.559		4300	0.26	34.0	0.566		7250	0.45	43.1	0.540		12300	0.73	61.3
	960	0.370		4300	0.18	34.0	0.375		7250	0.30	43.1	0.358		12300	0.49	61.3
	725	0.277		4300	0.13	34.0	0.281		7250	0.22	43.1	0.268		12300	0.36	61.3
2 8 c	2900	1.06	2733	4300	0.50	34.0	1.04	2779	7250	0.83	43.1	1.00	2887	12300	1.36	61.3
	1450	0.531		4300	0.25	34.0	0.522		7250	0.42	43.1	0.502		12300	0.68	61.3
	960	0.351		4300	0.17	34.0	0.345		7250	0.28	43.1	0.332		12300	0.45	61.3
	725	0.263		4300	0.12	34.0	0.259		7250	0.21	43.1	0.249		12300	0.34	61.3
3 2 c	2900	0.969	2992	4300	0.46	34.0	0.953	3044	7250	0.76	43.1	0.917	3162	12300	1.24	61.3
	1450	0.485		4300	0.23	34.0	0.476		7250	0.38	43.1	0.459		12300	0.62	61.3
	960	0.321		4300	0.15	34.0	0.315		7250	0.25	43.1	0.304		12300	0.41	61.3
	725	0.241		4300	0.11	34.0	0.237		7250	0.19	43.1	0.228		12300	0.31	61.3
3 6 c	2900	0.791	3667	4300	0.37	34.0	0.794	3652	7250	0.63	43.1	0.764	3794	12300	1.04	61.3
	1450	0.395		4300	0.19	34.0	0.397		7250	0.32	43.1	0.382		12300	0.52	61.3
	960	0.262		4300	0.12	34.0	0.263		7250	0.21	43.1	0.253		12300	0.34	61.3
	725	0.196		4300	0.09	34.0	0.197		7250	0.16	43.1	0.190		12300	0.26	61.3
4 0 c	2900	0.716	4048	4300	0.34	34.0	0.689	4208	7250	0.55	43.1	0.686	4226	12300	0.93	61.3
	1450	0.358		4300	0.17	34.0	0.345		7250	0.28	43.1	0.343		12300	0.47	61.3
	960	0.237		4300	0.11	34.0	0.228		7250	0.18	43.1	0.227		12300	0.31	61.3
	725	0.178		4300	0.08	34.0	0.171		7250	0.14	43.1	0.170		12300	0.23	61.3
4 5 c	2900	0.643	4512	4300	0.30	34.0	0.599	4842	7250	0.48	43.1	0.596	4862	12300	0.81	61.3
	1450	0.321		4300	0.15	34.0	0.299		7250	0.24	43.1	0.298		12300	0.40	61.3
	960	0.213		4300	0.10	34.0	0.198		7250	0.16	43.1	0.197		12300	0.27	61.3
	725	0.160		4300	0.076	34.0	0.149		7250	0.12	43.1	0.148		12300	0.20	61.3
5 0 c	2900	0.573	5060	4300	0.27	34.0	0.539	5380	7250	0.43	43.1	0.568	5110	12100	0.76	61.3
	1450	0.287		4300	0.14	34.0	0.270		7250	0.22	43.1	0.284		12100	0.38	61.3
	960	0.190		4300	0.090	34.0	0.178		7250	0.14	43.1	0.188		12100	0.25	61.3
	725	0.142		4300	0.067	34.0	0.134		7250	0.11	43.1	0.141		12100	0.19	61.3
5 6 c	2900	0.501	5793	4110	0.23	34.0	0.496	5845	7250	0.40	43.1	0.493	5879	12100	0.66	61.3
	1450	0.250		4110	0.11	34.0	0.248		7250	0.20	43.1	0.247		12100	0.33	61.3
	960	0.166		4110	0.075	34.0	0.164		7250	0.13	43.1	0.163		12100	0.22	61.3
	725	0.124		4110	0.056	34.0	0.123		7250	0.10	43.1	0.122		12100	0.16	61.3
6 3 c	2900	0.467	6207	4300	0.22	34.0	0.443	6548	7250	0.35	43.1	0.436	6657	12300	0.59	61.3
	1450	0.234		4300	0.11	34.0	0.221		7250	0.18	43.1	0.218		12300	0.30	61.3
	960	0.155		4300	0.073	34.0	0.147		7250	0.12	43.1	0.144		12300	0.20	61.3
	725	0.116		4300	0.055	34.0	0.110		7250	0.088	43.1	0.108		12300	0.15	61.3
7 1 c	2900	0.415	6980	4300	0.20	34.0	0.399	7276	7250	0.32	43.1	0.409	7083	12300	0.56	61.3
	1450	0.208		4300	0.10	34.0	0.199		7250	0.16	43.1	0.205		12300	0.28	61.3
	960	0.138		4300	0.065	34.0	0.132		7250	0.11	43.1	0.136		12300	0.18	61.3
	725	0.103		4300	0.049	34.0	0.099		7250	0.079	43.1	0.102		12300	0.14	61.3

0109

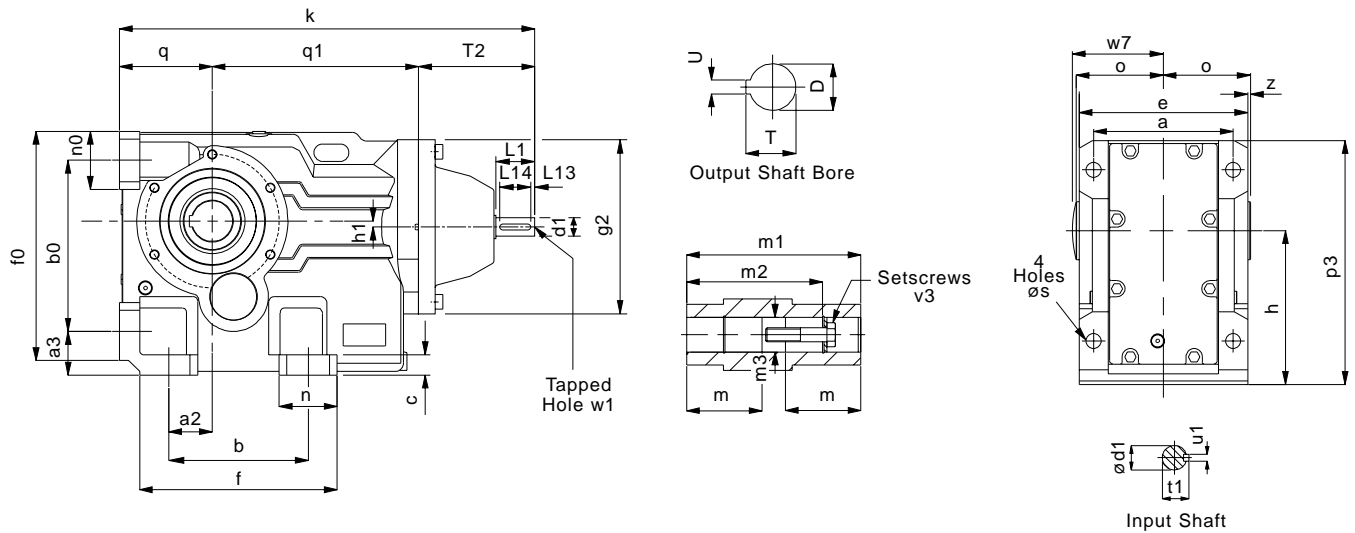

SIZE	a	a2	a3	b	b0	c	e	f	f0	g2	h	h1
K0332	100	28	32	110	115	11	120	143	152	140	100	16
K0432	120	35	37	130	130	16	145	168	171	140	112	13
K0532	130	30	45	130	150	15	157	170	192	180	132	5
K0632	140	30	45	120	160	20	170	176	208	180	140	13
K0732	165	40	55	150	200	27	200	210	263	212	180	25
K0832	180	55	70	180	233	30	230	256	309	250	212	15
K0931	240	75	75	240	295	35	290	340	395	300	265	10
K1031	270	95	95	280	360	40	340	390	455	360	315	41
K1231	330	115	110	350	420	45	400	470	540	400	375	65

SIZE	k	n	n0	o	p3	q	q1	T2	s	w7	z
K0332	333	38	38	60	167	63	159	111	11	63	0
K0432	361	38	40	75	187	71	179	111	11	78	2.5
K0532	410	40	40	83	217	80	219	111	14	87	4.5
K0632	430	55	48	90	233	90	229	111	14	94	5
K0732	492	60	55	105	288	112	265	115	18	109	5
K0832	622	76	76	120	341	132	330	160	23	124	5
K0931	710	100	100	150	420	160	355	195	27	154	5
K1031	856	110	115	175	513	200	423	233	34	180	5
K1231	987	120	120	205	590	225	476	286	39	210	5

SIZE	Input Shaft							Hollow Output Bore							
	d1	L1	L13	L14	t1	u1	w1	D	m	m1	m2	m3	T	U	v3
K0332	16 k6	40	4	32	18	5	M5x0.8, 12 deep	30	52.5	120	105	30.3	33.5	8	M10x50L
K0432	16 k6	40	4	32	18	5	M5x0.8, 12 deep	35	66	150	132	35.3	38.5	10	M12x55L
K0532	19 k6	40	4	32	21.5	6	M6x1.0, 16 deep	40	73	166	142	40.3	43.5	12	M16x70L
K0632	19 k6	40	4	32	21.5	6	M6x1.0, 16 deep	40	80	180	156	40.3	43.5	12	M16x70L
K0732	24 k6	50	5	40	27	8	M8x1.25, 19 deep	50	92.5	210	183	50.5	54	14	M16x70L
K0832	28 k6	60	5	50	31	8	M10x1.5, 22 deep	60	105	240	210	60.5	64.5	18	M20x80L
K0931	38 k6	80	5	70	41	10	M12x1.75, 28 deep	70	132.5	300	270	70.5	75	20	M20x80L
K1031	42 k6	110	10	70	45	12	M16x2.0, 36 deep	80	155	350	313	80.5	85.5	22	M20x80L
K1231	55 k6	110	10	90	59	16	M20x2.5, 42 deep	100	180	410	373	100.5	106.5	28	M24x110L

all parallel keys are to DIN 6885

0106

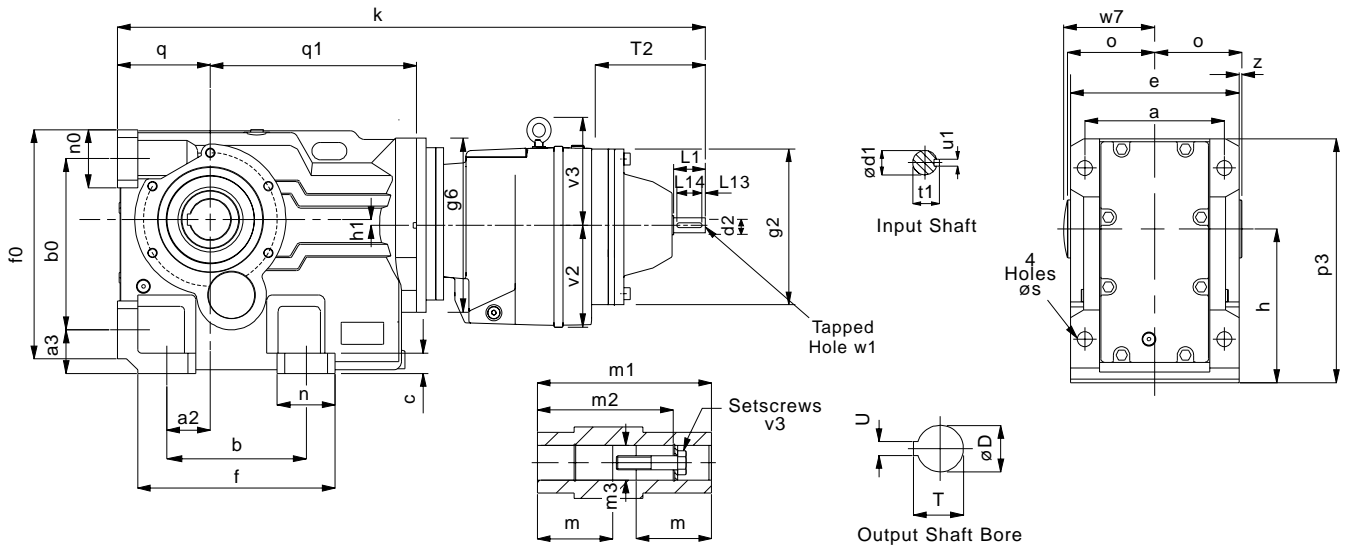

SIZE	a	a2	a3	b	b0	c	e	f	f0	g2	g6	h	h1
K0352	100	28	32	110	115	11	120	143	152	140	140	100	16
K0452	120	35	37	130	130	16	145	168	171	140	140	112	13
K0552	130	30	45	130	150	15	157	170	192	140	180	132	5
K0652	140	30	45	120	160	20	170	176	208	140	180	140	13
K0752	165	40	55	150	200	27	200	210	263	140	180	180	25
K0852	180	55	70	180	233	30	230	256	309	180	250	212	15
K0951	240	75	75	240	295	35	290	340	395	180	300	265	10
K1051	270	95	95	280	360	40	340	390	455	212	360	315	41
K1251	330	115	110	350	420	45	400	470	540	212	400	375	65

SIZE	k	n	n0	o	p3	q	q1	T2	s	w7	z	v2	v3
K0352	630	38	38	60	167	63	159	111	11	63	0	76	-
K0452	658	38	40	75	187	71	179	111	11	78	2.5	76	-
K0552	723	40	40	83	217	80	219	111	14	87	4.5	91	-
K0652	743	55	48	90	233	90	229	111	14	94	5	91	-
K0752	802	60	55	105	288	112	265	111	18	109	5	91	-
K0852	929	76	76	120	341	132	330	111	23	124	5	115	-
K0951	993	100	100	150	420	160	355	111	27	154	5	115	-
K1051	1145	115	110	175	513	200	423	115	34	180	5	140	155
K1251	1272	120	120	205	590	225	476	115	39	210	5	140	155

SIZE	Input Shaft							Hollow Output Bore							
	d1	L1	L13	L14	t1	u1	w1	D	m	m1	m2	m3	T	U	v3
K0352	16 k6	40	4	32	18	5	M5x0.8, 12 deep	30	52.5	120	105	30.3	33.5	8	M10x50L
K0452	16 k6	40	4	32	18	5	M5x0.8, 12 deep	35	66	150	132	35.3	38.5	10	M12x55L
K0552	16 k6	40	4	32	18	5	M5x0.8, 12 deep	40	73	166	142	40.3	43.5	12	M16x70L
K0652	16 k6	40	4	32	18	5	M5x0.8, 12 deep	40	80	180	156	40.3	43.5	12	M16x70L
K0752	16 k6	40	4	32	18	5	M5x0.8, 12 deep	50	92.5	210	183	50.5	54	14	M16x70L
K0852	19 k6	40	4	32	21.5	6	M6x1.0, 16 deep	60	105	240	210	60.5	64.5	18	M20x80L
K0951	19 k6	40	4	32	21.5	6	M6x1.0, 16 deep	70	132.5	300	270	70.5	75	20	M20x80L
K1051	24 k6	50	5	40	27	8	M8x1.25, 19 deep	80	155	350	313	80.5	85.5	22	M20x80L
K1251	24 k6	50	5	40	27	8	M8x1.25, 19 deep	100	180	410	373	100.5	106.5	28	M24x110L

all parallel keys are to DIN 6885

0108

Thermal Ratings kW

Thermal ratings are a measure of the units ability to dissipate heat, if they are exceeded the lubricant may break down resulting in premature gear failure.

Thermal rating are based on an ambient temperature of 20°C, where units are to operate in other ambient temperatures thermal ratings must be adjusted by the following factors

Unit Size	Ambient Temperature °C							
	-20	-10	0	10	20	30	40	50
All Units	1.57	1.43	1.29	1.14	1.00	0.86	0.71	0.5

Thermal Power (kW)

Overall Ratios	Type of Cooling	Input Rev/min	Unit Size								
			K03	K04	K05	K06	K07	K08	K09	K10	K12
8 to 20	Units with no additional cooling	2900	Consult Textron Power Transmission								
		1450	6.4	7.8	11.3	12.1	17.7	20.4	30.8	44	60
	cooling	960	6.1	7.4	10.8	11.6	16.9	19.5	29.4	42	57
		725	5.9	7.2	10.5	11.2	16.4	18.9	28.5	41	55
22 to 40	Units with no additional cooling	2900	4.6	5.7	8.2	8.8	12.9	14.8	22.3	32	43
		1450	5.4	6.6	9.6	10.3	15.1	17.7	25.1	35.0	47.9
	cooling	960	5.2	6.3	9.2	9.8	14.4	16.9	24.0	33	46
		725	5.0	6.1	8.9	9.5	13.9	16.4	23.2	32	44
45 & over	Units with no additional cooling	2900	3.9	4.8	7.0	7.5	10.9	12.8	18.2	25	35
		1450	4.1	5.8	5.8	9.8	9.8	14.5	19.2	30	42
	cooling	960	5.2	6.3	9.2	9.8	14.4	16.9	24.0	33	46
		725	5.0	6.1	8.9	9.5	13.9	16.4	23.2	32	44
8 to 20	Units with Fan cooling	2900	N/A	N/A	N/A	N/A	N/A	N/A	N/A	N/A	N/A
		1450	-	-	-	-	35	41	62	88	119
	cooling	960	-	-	-	-	31	36	54	77	104
		725	-	-	-	-	27	31	46	66	89
22 to 40	Units with Fan cooling	2900	N/A	N/A	N/A	N/A	N/A	N/A	N/A	N/A	N/A
		1450	-	-	-	-	30	35	50	70	96
	cooling	960	-	-	-	-	26	31	44	61	84
		725	-	-	-	-	23	27	38	53	72
45 & over	Units with Fan cooling	2900	N/A	N/A	N/A	N/A	N/A	N/A	N/A	N/A	N/A
		1450	-	-	-	-	20	29	38	59	85
	cooling	960	-	-	-	-	17	25	34	52	74
		725	-	-	-	-	15	22	29	44	63

Note: When checking thermal capacities use actual load required to be transmitted, not rating of prime mover.

0106

Column 10 Entry

For reducer fan kit modules enter **S** in column 10
or if used in conjunction with a reducer backstop module kit

Y CW rotation
Z CCW rotation

Dimensions of Fan Cooled Units

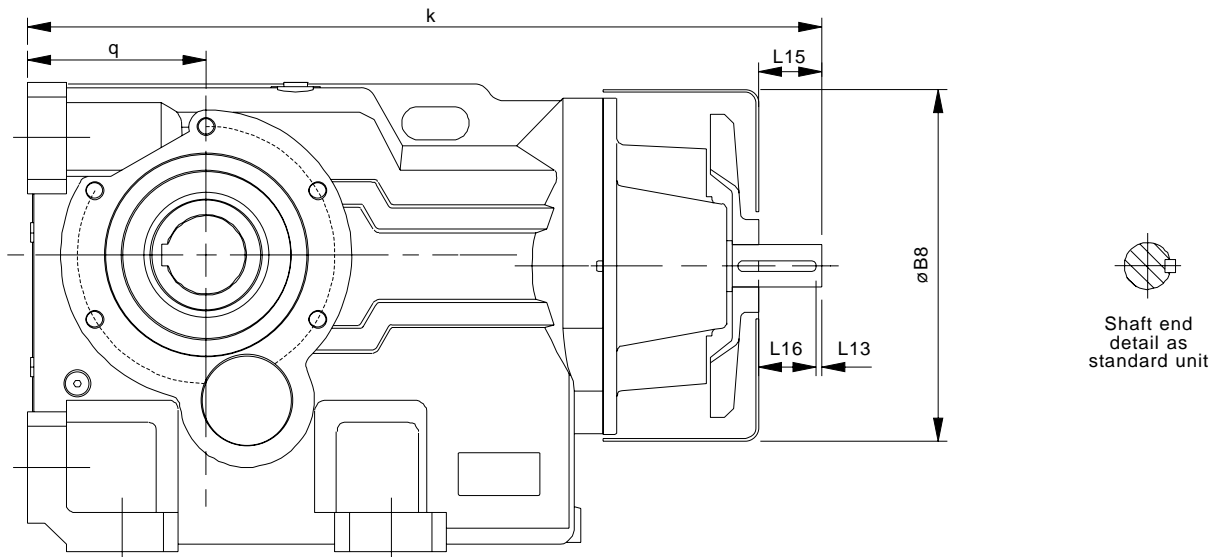

Unit Size	øB8	k	L13	L15	L16	q
K0732	225	492	5	35	30	112
K0832	265	622	5	45	40	132
K0931	320	710	5	65	60	160
K1031	380	856	10	95	85	200
K1231	420	987	10	85	75	225

REDUCER BACKSTOP MODULE

0105

The reducer units listed below can be fitted with an internal backstop, this has no effect of the external unit size. The backstop device incorporates high quality centrifugal lift off sprags which are wear free above the lift off speed (n min). To ensure correct operation input speed must exceed lift off speed.

Suitable for ambient temperature -40°C to + 50°C

Column 10 Entry

For reducer backstop modules enter W for CCW rotation (or Z if used in conjunction with a fan kit)
 X for CW rotation (or Y if used in conjunction with a fan kit)

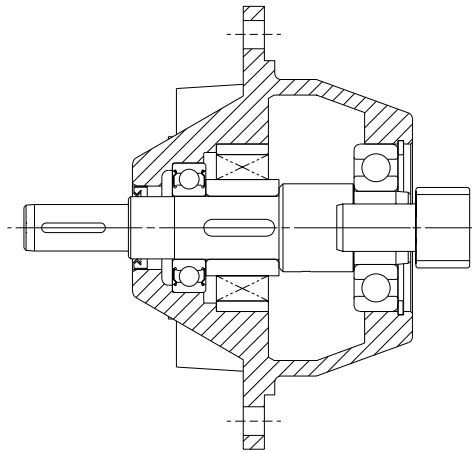

Unit Size	Lift off Speed ('n' min) (at inputshaft) (rev/min)	Rated Locking Torque ('T max') (at inputshaft) (Nm)
K0532	800	100
K0632	800	100
K0732	670	170
K0832	670	170
K0931	670	300
K1031	670	300
K1231	550	2400

Rotation of outputshaft must be specified when ordering as viewed from the outputshaft end (as shown in the diagram)

- CW - Free Rotation - Clockwise
- Locked - Anticlockwise

- AC - Free Rotation - Anticlockwise
- Locked - Clockwise

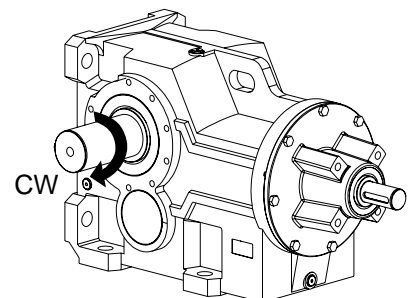

0205

STANDARD OUTPUTSHAFT OPTION

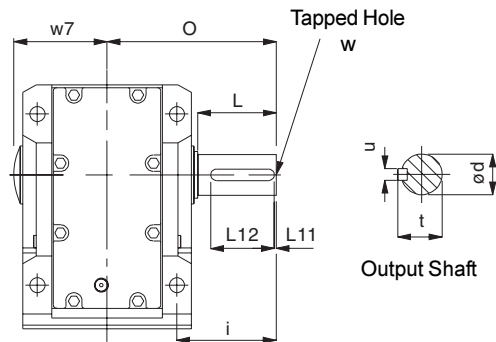

all parallel keys are to DIN 6885

SIZE	ød	i	L	L11	L12	O	t	u	w	w7
K0332	25.015 / 25.002	60	47	3	40	110	28	8	M10 x 1.5, 22 Deep	63
K0432	30.015 / 30.002	75	56	3	50	135	33	8	M12 x 1.75, 28 Deep	78
K0532	35.018 / 35.002	88	66	3	56	153	38	10	M16 x 2, 36 Deep	87
K0632	40.018 / 40.002	101	76	3	70	171	43	12	M16 x 2, 36 Deep	94
K0732	50.018 / 50.002	123.5	95	3	80	206	53.5	14	M16 x 2, 36 Deep	109
K0832	60.030 / 60.011	150	114	3	100	240	64	18	M20 x 2.5, 42 Deep	124
K0931	70.030 / 70.011	171	135	3	110	291	74.5	20	M20 x 2.5, 42 Deep	154
K1031	90.035 / 90.013	212	172	5	140	347	95	25	M20 x 2.5, 42 Deep	180
K1231	110.035 / 110.013	253	213	5	180	418	116	28	M24 x 3, 55 Deep	210

STANDARD DOUBLE EXTENDED OUTPUTSHAFT OPTION

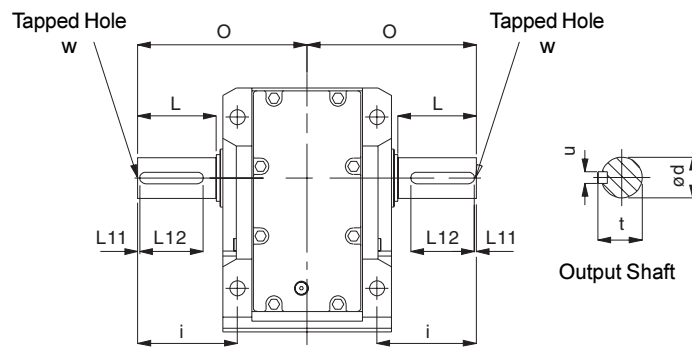

all parallel keys are to DIN 6885

SIZE	d	i	L	L11	L12	O	t	u	w
K0332	25.015 / 25.002	60	47	3	40	110	28	8	M10 x 1.5, 22 Deep
K0432	30.015 / 30.002	75	56	3	50	135	33	8	M12 x 1.75, 28 Deep
K0532	35.018 / 35.002	88	66	3	56	153	38	10	M16 x 2, 36 Deep
K0632	39.991 / 39.975	101	76	3	70	171	43	12	M16 x 2, 36 Deep
K0732	49.991 / 49.975	123.5	95	3	80	206	53.5	14	M16 x 2, 36 Deep
K0832	59.990 / 59.971	150	114	3	100	240	64	18	M20 x 2.5, 42 Deep
K0931	69.990 / 69.971	171	135	3	110	291	74.5	20	M20 x 2.5, 42 Deep
K1031	75.030 / 75.011	203	163	5	110	347	79.5	20	M20 x 2.5, 42 Deep
K1231	95.035 / 95.013	240	200	5	140	418	100	25	M20 x 2.5, 42 Deep

0203

Advantages with Kibo taper bushes

- Simple design
- Easy to mount
- Easy to dismount, built in puller
- Tapered bushes assure a safe mounting
- Reduces risk for shearing of key
- Bushings for different bore dimensions are available

The Kibo bush kit comprises of: bushes, locking nuts, end plate, fastening bolt, shaft key and protective cover.

Mounting

For correct mounting of speed reducer it is important that both bushings get the same squeezing force.

1. Mount the inner bushing with the nut in its outer position. The bushing should be mounted against the shoulder or circlip. The shoulder should not exceed inside diameter of nut.
2. Fit the key in the keyway.
3. Mount the reducer on the machine-shaft and press it against the inner bushing
4. Mount the outer bushing with the nut in it's inner position. Check that the bushing is not squeezed but the nut is in contact with the shaft sleeve.
5. Mount the end plate with its fixing bolt. Tighten the bolt with correct torque. The inner bushing is now locked.
6. Loosen the bolt, so the outer bushing is loose. Turn the nut on the bushing, in it's outer position.
7. Tighten the bolt once again with correct torque. The outer bushing is now locked.
The thicker end plate may be changed to the thinner one in order to gain more space at the hollow shaft end. The thinner end plate should be tightened with a torque of 25% of the value given in the table below.
8. Screw the nuts against the hollow shaft by hand, mounting is completed.
9. Fit protective cover.

Dismounting

- Loosen the bolt and take away the end plate.
- Pull out the outer bushing with the nut, by turning the nut with an adequate tool. Take out the bushing.
- Press the reducer from the inner bushing with the nut, dismounting is completed.

NOTE:

If reducer is mounted in a corrosive environment, ensure machine shaft bushings and nuts are oiled or greased.
Do NOT use grease based on molybdendisulfide.

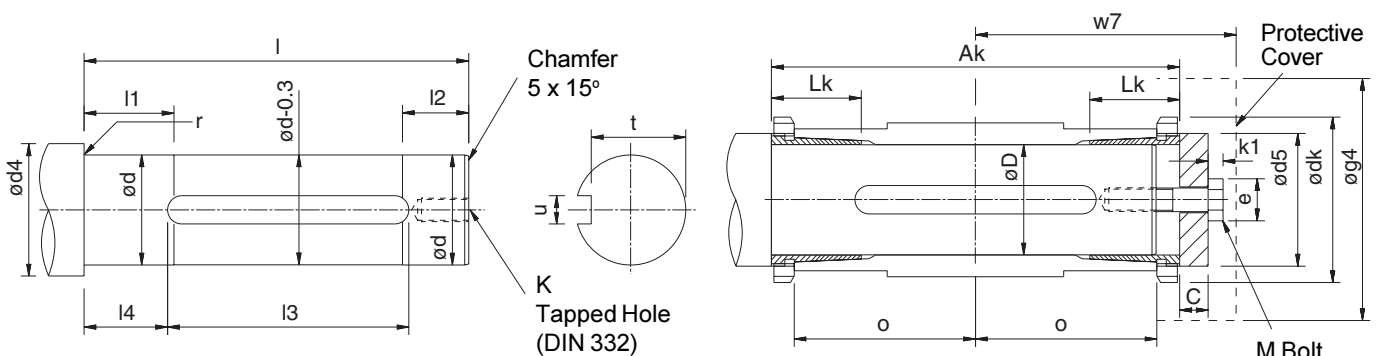

0208

Unit Size	Customers Shaft											
	ød (h8)	ød4		K (DIN 332)	l	l1	l2	l3	l4	r (max)	t	u (N9)
		min	max									
K04	35	40	42	M12x28	171	40	36	50	63	1.2	30	10
	32	37									27	10
	30	35		26							8	
	25	30		21							8	
K05	35	40	42	M12x28	187	40	36	50	63	1.2	30	10
	32	37									27	10
	30	35		26							8	
	25	30		21							8	
K06	45	50	51	M16x36	200	50	45	65	70	1.2	39.5	14
	40	45		M12x28							35	12
	35	40		M10x22							30	10
	30	35		26							8	
K07	55	60	61	M20x42	238	58	55	65	88	1.2	49	16
	50	55		M16x36							44.5	14
	45	50									39.5	14
	40	45		35							12	
K08	60	66	71	M20x42	262	61	50	90	92	1.6	53	18
	55	61		M16x36							49	16
	50	56									44.5	14
	45	51		39.5							14	
K09	70	76	81	M20x42	322	68	51	110	115	1.6	62.5	20
	65	71									58	18
	60	66									53	18
	55	61									49	16
K10	85	93	96	M20x42	377	67	67	141	126	2	76	22
	80	88									71	22
	75	83									67.5	20
	70	78									62.5	20
K12	100	110	116	M24x50	433	70	51	160	148	2.5	90	28
	95	105									86	25
	90	100		81							25	
	85	95		76							22	
	80	90		M20x42							71	22

Unit Size	Hollow Shaft							End Plate						Cover	
	øD	KIBO Bush Kit	Column 11 Entry	ødk	o	Ak	Lk	ød5	C	Fixing Bolt			Tightening Torque Nm	øg4	w7
										M	e	k1			
K04	35	C38214-S1	1	65	75	175	40	45	10	M12	22	8	56	108	113
	32	C38214-S2	2												
	30	C38214-S3	3							M10	20	7	40		
	25	C38214-S4	4												
K05	35	C38214-S1	1	65	83	191	40	45	10	M12	22	8	56	108	118
	32	C38214-S2	2												
	30	C38214-S3	3							M10	20	7	40		
	25	C38214-S4	4												
K06	45	C38364-S1	1	75	90	205	50	55	12	M16	28	10	124	133	140
	40	C38364-S2	2												
	35	C38364-S3	3							M12	22	8	70		
	30	C38364-S4	4												
	25	C38364-S5	5							M10	20	7	40		
55	C38534-S1	1	85	105	241	58	65	14	M20					35	13
50	C38534-S2	2													
45	C38534-S3	3							M16	28	10	154			
40	C38534-S4	4													
K08	60	C38614-S1	1	98	120	273	61	75	16	M20	35	13	240	162	175
	55	C38614-S2	2												
	50	C38614-S3	3							M16	28	10	169		
	45	C38614-S4	4												
K09	70	C38684-S1	1	110	150	340	67.5	85	20	M20	35	13	290	192	210
	65	C38684-S2	2												
	60	C38684-S3	3												
	55	C38684-S4	4												
K10	85	C38744-S1	1	130	175	392	53	100	24	M20	35	13	274	242	265
	80	C38744-S2	2												
	75	C38744-S3	3												
	70	C38744-S4	4												
K12	100	C38834-S1	1	155	205	455	68	130	12.5	M24	42	15	400	242	295
	95	C38834-S2	2												
	90	C38834-S3	3							M20	35	13	331		
	85	C38834-S4	4												
	80	C38834-S5	5												

0208

The gear unit is fitted with a 'shrink disc' device located on the hollow output shaft to provide a positive outer locking connection between gear unit and driven shaft. The 'shrink disc' is a friction device, without keys, which exerts an external clamping force on the hollow output shaft, thus establishing a mechanical shrink fit between the gear unit hollow shaft and driven shaft. 'Shrink disc' capacities have ample margins in dealing with transmitted torques and external loading imposed on gear units.

WORKING PRINCIPLE

The 'shrink disc' consists of a locking collar, a tapered inner ring and locking screws. By tightening the locking screws, the locking collar and tapered inner ring are pulled together, exerting radial forces on the inner ring, thus creating a positive friction connection between hollow shaft and driven shaft.

As the tapered surfaces of locking collar and inner ring are lubricated with Molykote 321R or similar and the taper angle is not self locking, locking collar will not seize on the inner ring and can be released easily when removal is necessary.

When the shrink disc is clamped in position the high contact pressures between tapered surfaces and screw heads and their seatings ensure hermetic sealing and eliminate the possibility of fretting corrosion.

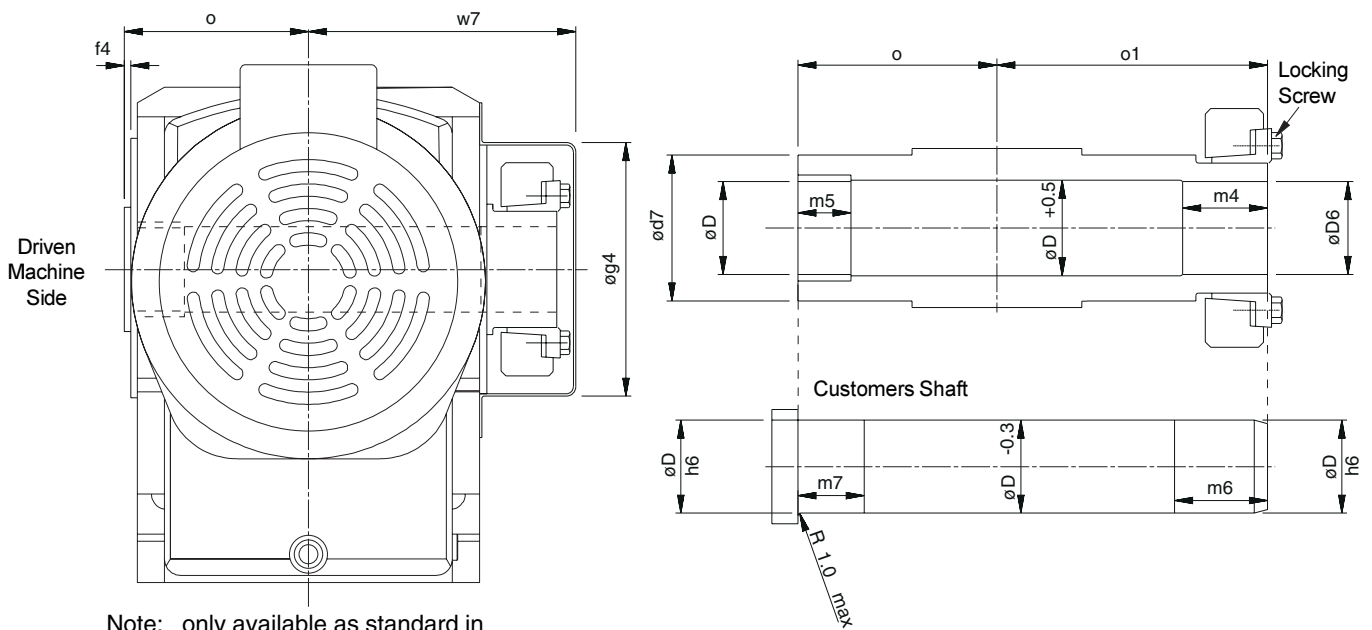

Note: only available as standard in this handing, please contact Textron Power Transmission for opposite handing

SIZE	D	D6	d7	f4	g4	m4	m5	m6	m7	o	o1	w7	Locking Screws Torque Ta (Nm)
K03	30	30	50	2.5	88.5	31	20	36	25	60	86	91	29
K04	35	35	55	2.5	108	32	20	37	25	75	102	113	29
K05	40	40	60	3	108	36	20	41	25	83	112	118	29
K06	40	40	70	3.5	133	38	20	43	25	90	118	140	29
K07	50	50	80	6	133	36	30	41	35	105	136	152	35
K08	65	65	90	5	162	41	40	46	45	120	161	175	58
K09	75	75	100	5	192	55	40	60	55	150	195	210	58
K10	95	95	120	5	242	65	60	70	65	175	230	265	100
K12	105	105	140	5	242	85	60	90	75	205	280	295	160

0208

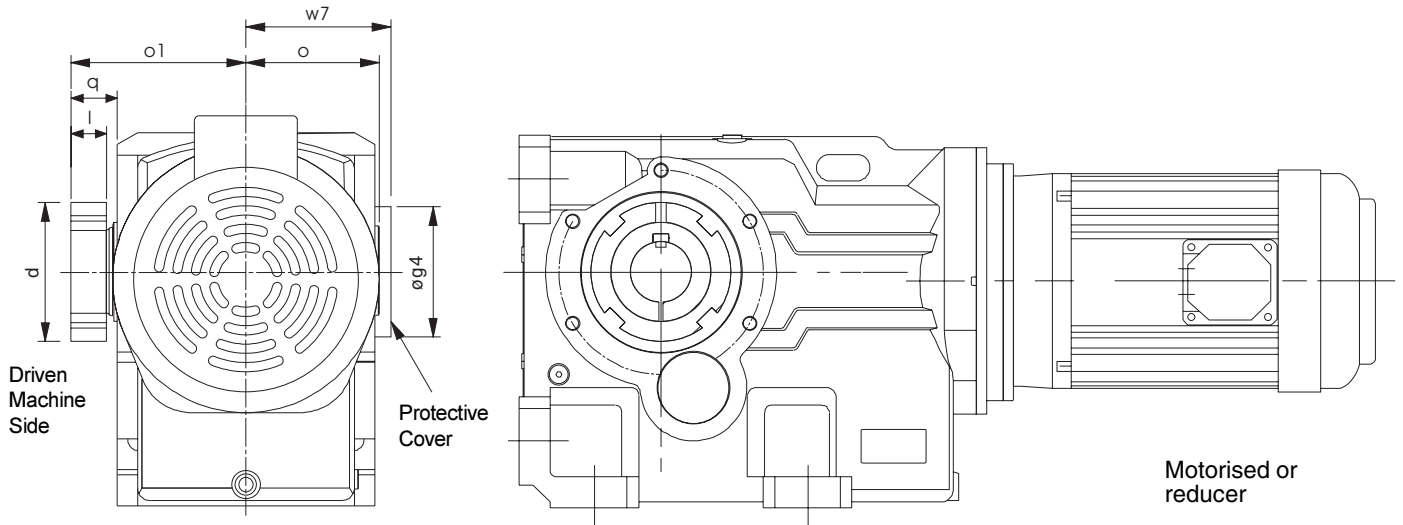

Note: only available as standard in this handing, please contact Textron Power Transmission for opposite handing

Driven shaft

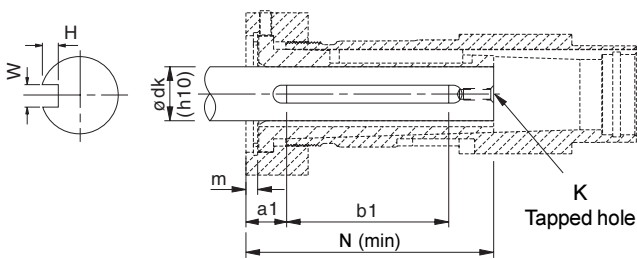

Thin walled

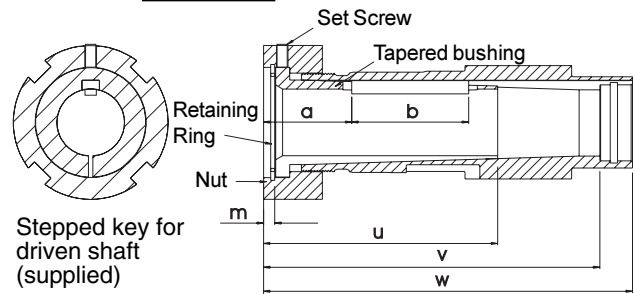

End plate (not supplied)

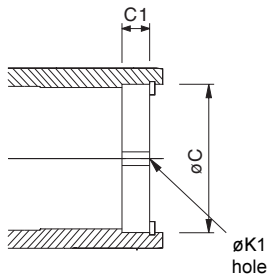

Thick walled

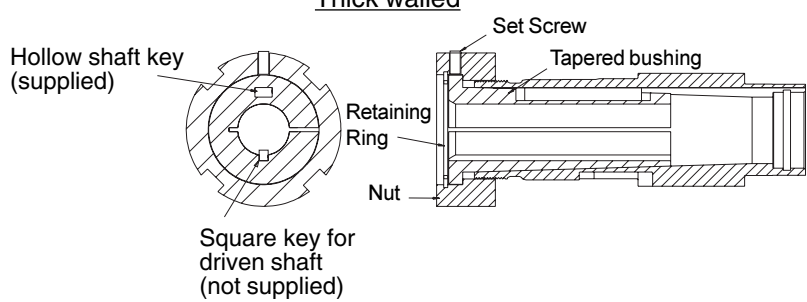

- Consult standard unit selection tables for kW and torque ratings

SIZE	key		bush		hollow shaft			nut			gear unit			cover	
	a	b	u	v	w	d	l	m	o	o1	q	g4	w7		
K05 (107)TR	48	64	127	170	199	84	32	7	116	83	41	108	118		
K06 (115)TR	53	70	141	190	218	103	37	8	128	90	45	133	140		
K07 (203)TR	40	83	141	210	241	108	37	8	136	105	41	133	152		
K08 (207)TR	32	108	155	265	287	122	37	8	167	120	52	162	175		
K09 (215)TR	53	89	180	329	352	145	45	10	202	150	57	192	210		
K10 (307)TR	40	127	188	366	406	154	45	10	231	175	61	242	265		
K12 (315)TR	48	127	201	426	467	173	46	11	262	205	62	242	295		

- All other gear unit dimensions may be obtained from the standard unit dimension pages

0106

size	Driven shaft diameter * (ødk)	bushing style	driven shaft keyway			driven shaft			end plate			circlip	bushing weight (kg)
			width (W)	depth (H)	min length ▲ (b1)	a1	K	N (min)	øC	C1	K1		
K05 (107)TR	25	Thick	8	4	110	-	M12	127	41	7.5	M16	N1300-0162	1.0
	30	Thick	8	4	110	-	M12	127	41	7.5	M16	N1300-0162	0.8
	32	Thin	10	5	74	48	M12	127	41	7.5	M16	N1300-0162	0.7
	35	Thin	10	5	74	48	M12	127	41	7.5	M16	N1300-0162	0.6
K06 (115)TR	30	Thick	8	4	125	-	M12	141	57	9	M16	N1300-0225	2.0
	32	Thick	10	5	125	-	M12	141	57	9	M16	N1300-0225	2.0
	35	Thick	10	5	125	-	M12	141	57	9	M16	N1300-0225	1.7
	38	Thick	10	5	125	-	M12	141	57	9	M16	N1300-0225	1.5
	40	Thin	12	5	82	53	M12	141	57	9	M16	N1300-0225	1.5
	42	Thin	12	5	82	53	M12	141	57	9	M16	N1300-0225	1.3
K07 (203)TR	45	Thin	14	5.5	84	53	M12	141	57	9	M16	N1300-0225	1.0
	35	Thick	10	5	125	-	M16	141	61	11	M20	N1300-0244	2.4
	38	Thick	10	5	125	-	M16	141	61	11	M20	N1300-0244	2.2
	40	Thick	12	5	125	-	M16	141	61	11	M20	N1300-0244	2.0
	42	Thick	12	5	125	-	M16	141	61	11	M20	N1300-0244	1.9
	45	Thick	14	5.5	100	-	M16	141	61	11	M20	N1300-0244	1.4
K08 (207)TR	50	Thin	14	5.5	97	40	M16	141	61	11	M20	N1300-0244	1.4
	55	Thin	16	6	99	40	M16	141	61	11	M20	N1300-0244	1.0
	40	Thick	12	5	155	-	M16	155	71	11	M20	N1300-0281	3.0
	42	Thick	12	5	155	-	M16	155	71	11	M20	N1300-0281	3.0
	45	Thick	14	5.5	155	-	M16	155	71	11	M20	N1300-0281	2.8
	50	Thin	14	5.5	122	32	M16	155	71	11	M20	N1300-0281	2.4
K09 (215)TR	55	Thin	16	6	124	32	M16	155	71	11	M20	N1300-0281	2.0
	60	Thin	18	7	126	32	M16	155	71	11	M20	N1300-0281	1.4
	50	Thick	14	5.5	180	-	M20	180	84	12.5	M24	N1300-0334	5.0
	55	Thick	16	6	180	-	M20	180	84	12.5	M24	N1300-0334	4.6
	60	Thick	18	7	180	-	M20	180	84	12.5	M24	N1300-0334	4.6
K10 (307)TR	65	Thin	18	7	107	53	M20	180	84	12.5	M24	N1300-0334	3.4
	70	Thin	20	7.5	109	53	M20	180	84	12.5	M24	N1300-0334	2.7
	60	Thick	18	7.0	180	-	M24	188	95	14	M30	N1300-0375	7.0
	65	Thick	18	7.0	180	-	M24	188	95	14	M30	N1300-0375	6.4
	70	Thin	20	7.5	147	40	M24	188	95	14	M30	N1300-0375	5.7
	75	Thin	20	7.5	147	40	M24	188	95	14	M30	N1300-0375	5.0
K12 (315)TR	80	Thin	22	9.0	149	40	M24	188	95	14	M30	N1300-0375	5.0
	85	Thin	22	9.0	149	40	M24	188	95	14	M30	N1300-0375	3.3
	70	Thick	20	7.5	200	-	M24	201	109	19	M30	N1300-0433	10
	75	Thick	20	7.5	200	-	M24	201	109	19	M30	N1300-0433	9.0
	80	Thick	22	9.0	200	-	M24	201	109	19	M30	N1300-0433	8.0
	85	Thin	22	9.0	149	48	M24	201	109	19	M30	N1300-0433	7.0
	90	Thin	25	9.0	152	48	M24	201	109	19	M30	N1300-0433	6.0
95	Thin	25	9.0	152	48	M24	201	109	19	M30	N1300-0433	5.0	
100	Thin	28	10	155	48	M24	201	109	19	M30	N1300-0433	4.0	

* Check strength of driven shaft

▲ Check strength and length of key (when key not supplied ie thick wall bushing)

0106

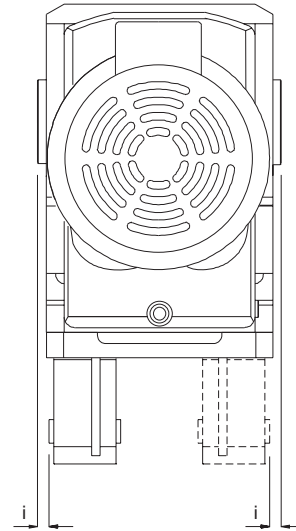
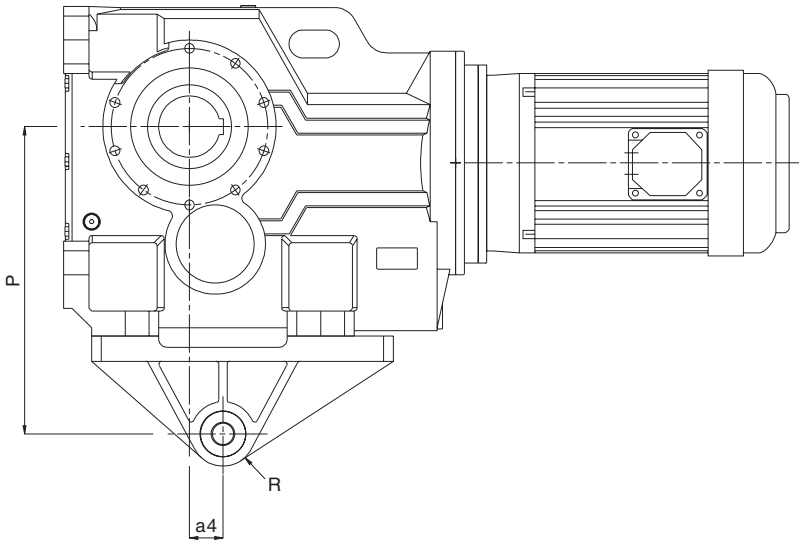

Column 9 Entry

Column 9 Entry

T Torque bracket on left

Q Torque bracket on right

The torque arm requires a Stirrup type anchoring

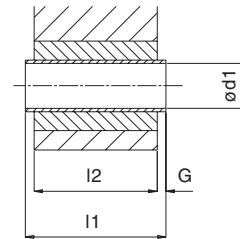
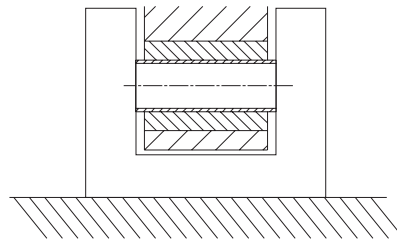

SIZE	a4	d1	G	i	l1	l2	P	R
K03	23.5	10.5 10.3	2	20	36	32	140	20
K04	30	10.5 10.3	2	20	36	32	160	20
K05	40	16.5 16.3	2	18	60	56	192	35
K06	45	16.5 16.3	2	25	60	56	200	35
K07	52.5	16.5 16.3	2	25	60	56	250	35
K08	60	25.25 24.75	5	30	80	70	300	40
K09	70	25.25 24.75	5	40	100	90	350	40
K10	74	25.25 24.75	5	45	100	90	450	40
K12	60	38.25 37.75	8	10	126	110	550	58

NOTES:

It is recommended that the torque arm is fitted on the side of the unit adjacent to the driven machine.

The use of a fitted bolt is recommended.

0208

Sizes K09 to K12

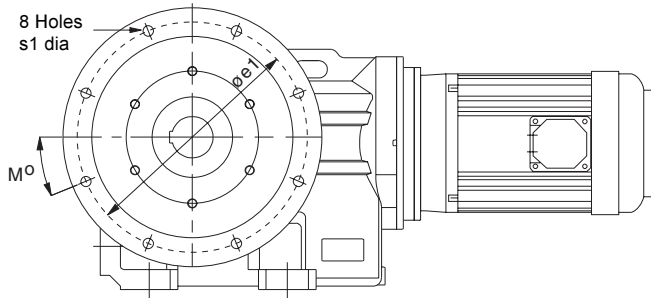

Sizes K03 to K08

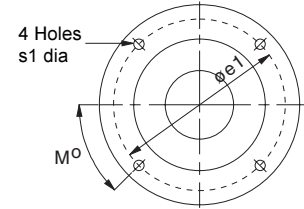

Column 9 Entry

F B5 (D) Output Flange on Left

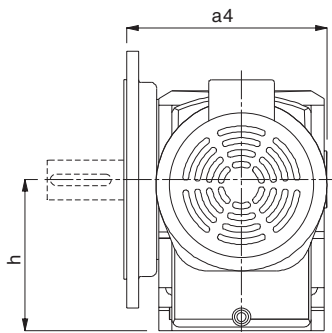

Column 9 Entry

H B5 (D) Output Flange on Right

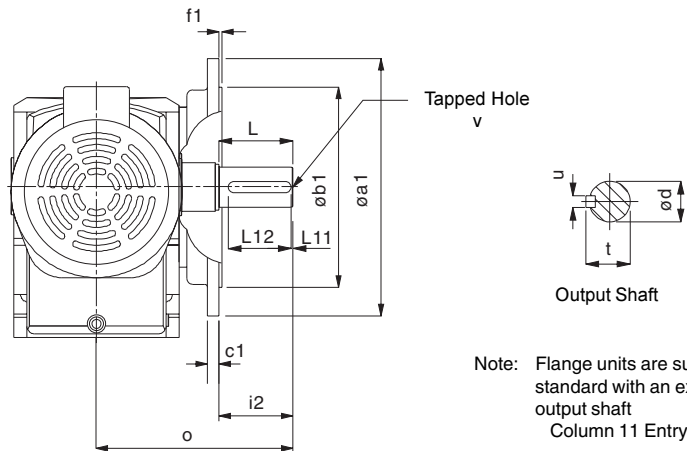

Note: Flange units are supplied as standard with an extended output shaft
Column 11 Entry **F**

SIZE	øa1	a4	øb1	c1	øe1	f1	h	m	øs1
K03	160	144	110 j6	10	130	3.5	100	45°	9
K04	200	190	130 j6	12	165	3.5	112	45°	11
K05	250	189	180 j6	16	215	4	132	45°	14
K06	250	220	180 j6	16	215	4	140	45°	14
K07	300	247	230 j6	18	265	4	180	45°	14
K08	350	285	250 h6	18	300	5	212	45°	18
K09	450	351	350 h6	20	400	5	265	22.5°	18
K10	450	410.5	350 h6	22	400	5	315	22.5°	18
K12	450	470.5	350 h6	22	400	5	375	22.5°	18

SIZE	Extended Output Shaft - Column 11 Entry F								
	d	i2	L	L11	L12	o	t	u	v
K0332	25.015 / 25.002	50	50	3	40	134	28	8	M10 x 1.5, 22 Deep
K0432	30.015 / 30.002	60	60	3	50	175	33	8	M12 x 1.75, 28 Deep
K0532	35.018 / 35.002	70	70	3	60	176	38	10	M16 x 2, 36 Deep
K0632	40.018 / 40.002	80	80	3	70	210	43	12	M16 x 2, 36 Deep
K0732	50.018 / 50.002	100	100	3	80	242	53.5	14	M16 x 2, 36 Deep
K0832	60.030 / 60.011	120	120	3	100	285	64	18	M20 x 2.5, 42 Deep
K0931	70.030 / 70.011	140	140	3	110	341	74.5	20	M20 x 2.5, 42 Deep
K1031	90.035 / 90.013	170	170	5	140	405.5	95	25	M20 x 2.5, 42 Deep
K1231	110.035 / 110.013	210	210	5	180	475.5	116	28	M24 x 3, 55 Deep

0107

K03, K04 & K08

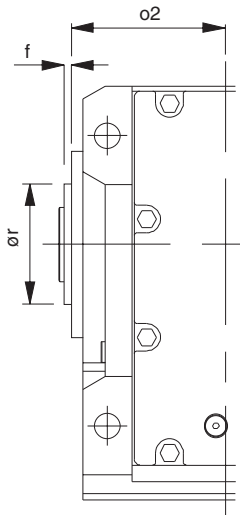
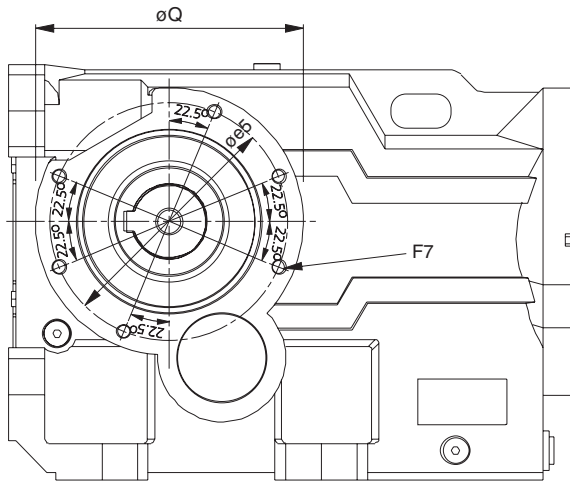

Male spigot
K03 - K07

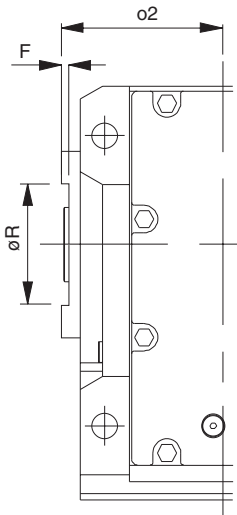

Female recess
K08 - K12

K05

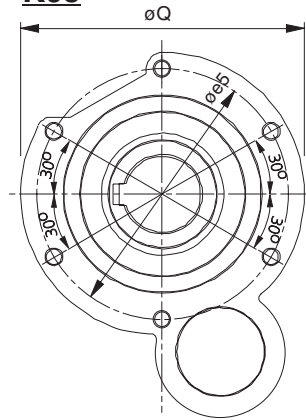

K06

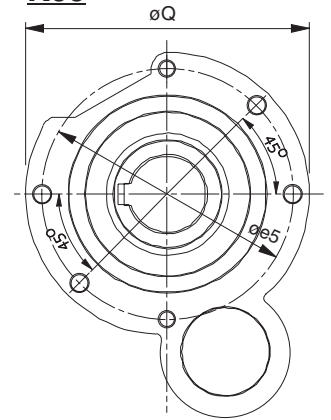

K07

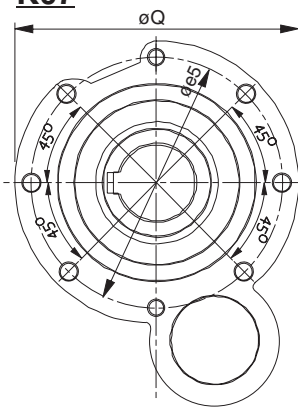

K09

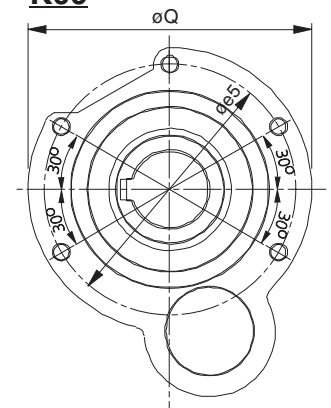

K10

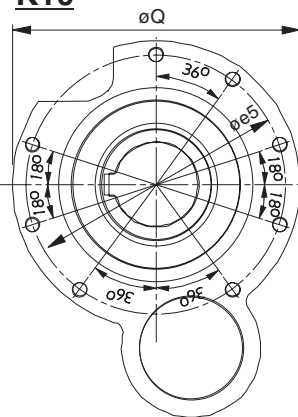

K12

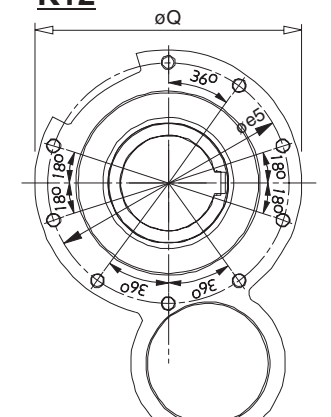

SIZE	$\phi e5$	F7	$\phi 2$	Q	ϕr h7 spigot ϕ	$\phi RH7$	Spigot f	Recess F
K03	107 pcd	6 Holes M8 x 1.25, 12 Deep	55	122	85	-	2.5	-
K04	130 pcd	6 Holes M8 x 1.25, 12 Deep	70	146	105	-	2.5	-
K05	125 pcd	6 Holes M10 x 1.5, 17 Deep	75	150	105	-	3.0	-
K06	150 pcd	6 Holes M10 x 1.5, 17 Deep	83	180	130	-	3.5	-
K07	150 pcd	8 Holes M10 x 1.5, 17 Deep	95	180	130	-	6.0	-
K08	195 pcd	6 Holes M12 x 1.75, 20 Deep	115	220	-	150	-	5.0
K09	230 pcd	5 Holes M16 x 2.0, 27 Deep	145	260	-	180	-	6.0
K10	280 pcd	8 Holes M16 x 2.0, 27 Deep	170	310	-	210	-	7.0
K12	280 pcd	9 Holes M16 x 2.0, 27 Deep	200	310	-	210	-	7.0

0206

ASSEMBLY ONTO SHAFT - CUSTOMERS SHAFT DETAIL

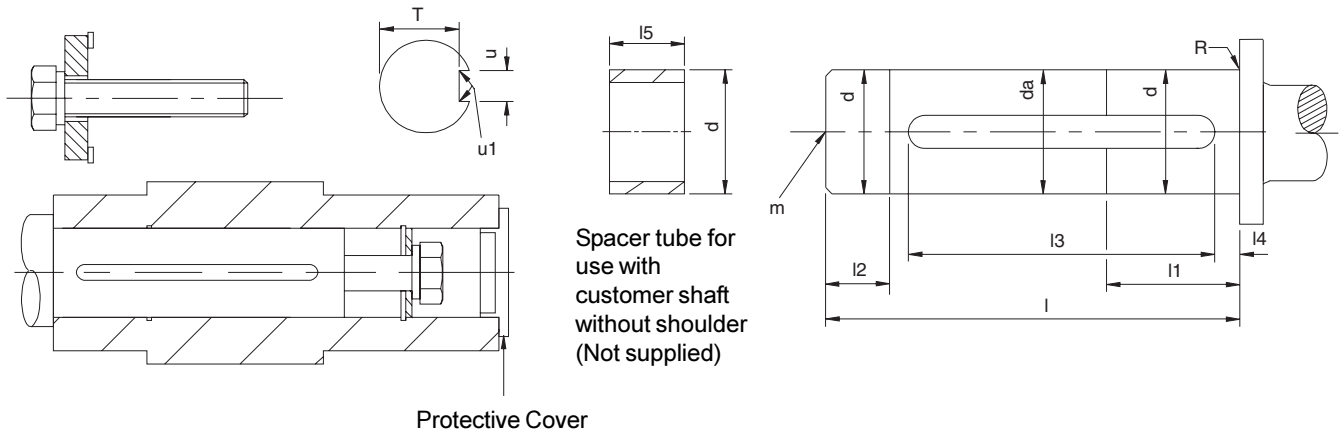

SIZE	d	da	l	l1	l2	l3	l4	l5	m	N	R	T	u	u1
K03	29.993/	29.6	82	45	15	70.3	3	23	M10 x 1.5	15 Nm	0.8R	26.0	8.000 /	0.16
	29.980												7.964	
K04	34.991/	34.6	109	60	20	90.5	3	23	M12 x 1.75	20 Nm	0.8R	30.0	10.000 /	0.16
	34.975												9.964	
K05	39.991/	39.6	112	60	20	92.5	3	30	M16 x 2	45 Nm	0.8R	35.0	12.000 /	0.4
	39.975												11.957	
K06	39.991/	39.6	126	75	25	100.5	3	30	M16 x 2	45 Nm	0.8R	35.0	12.000 /	0.4
	39.975					100.0							11.957	
K07	49.991/	49.6	153	90	30	130.5	3	30	M16 x 2	45 Nm	0.8R	44.5	14.000 /	0.4
	49.975					130.0							13.957	
K08	59.990 /	59.6	173	90	143	148.5	3	37	M20 x 2.5	85 Nm	0.8R	53	18.000 /	0.4
	59.971					148.0							17.957	
K09	69.990 /	69.6	232	105	197	161.5	3	38	M20 x 2.5P	85 Nm	0.8R	62.5	20.000 /	0.6
	69.971					161.0							19.948	
K10	79.990 /	79.6	275	120	235	188.5	5	37	M20 x 2.5P	85 Nm	0.8R	71	22.000 /	0.6
	79.971					188.0							21.948	
K12	99.988/	99.6	327	150	277	238.5	10	46	M24 x 3	200 Nm	0.8R	90	28.000/	0.4
	99.966					238.0							27.948	

Assembly Instructions

1. Spray the hollow shaft bore and mating diameter of the output shaft with Rocol DFMS or equivalent anti-scuffing spray.
2. Fit key into shaft.
3. Fit the circlip into the output sleeve.
4. Fit the spacer tube only if the output shaft has no shoulder, then fit the output shaft into the output sleeve.
5. Secure in place with the washer and bolt. Torque tighten to the values stated in column N of the above table.
6. Fit plastic protective cover.

0208

DISASSEMBLY METHOD FROM SHAFT

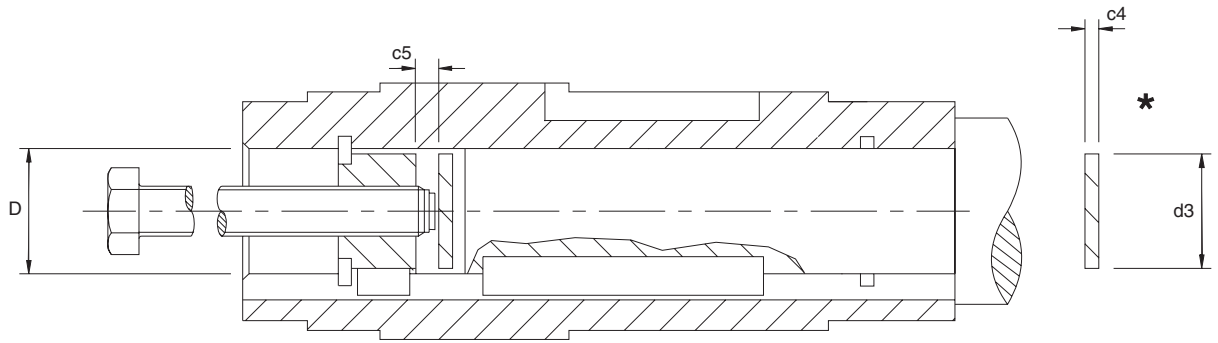

* PARTS SUPPLIED BY CUSTOMER

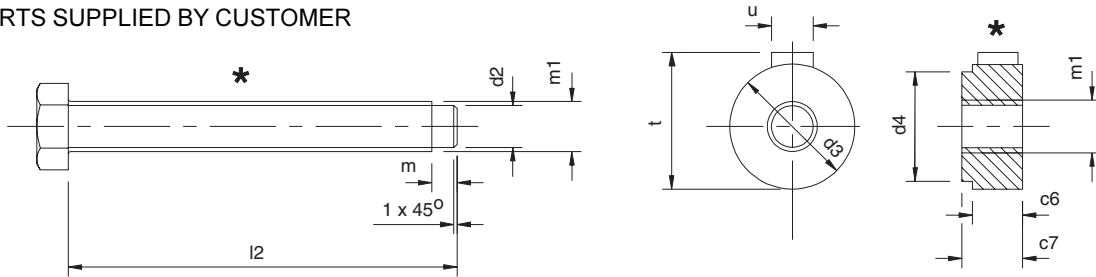

SIZE	c4	c5	c6	c7	D	d2	d3	d4	l2	m	m1	t	u
K03	5	3.00	15	17	30	13	29.9	20.8	130	3	M16 x 1.5	33	8
K04	5	3.00	15	17	35	13	34.9	25.2	160	3	M16 x 1.5	38	10
K05	5	4.00	20	23	40	20	39.9	29.9	190	3	M24 x 1.5	43	12
K06	5	4.00	20	23	40	20	39.9	29.9	190	3	M24 x 1.5	43	12
K07	5	4.00	20	23	50	20	49.9	39.0	220	3	M24 x 1.5	53.5	14
K08	8	5.00	24	27	60	26	59.9	47.4	250	5	M30 x 1.5	64	18
K09	8	6.05	24	27	70	26	69.9	56.4	310	5	M30 x 1.5	74.5	20
K10	8	6.00	24	27	80	26	79.9	65.5	360	5	M30 x 1.5	95	22
K12	8	8.00	30	34	100	32	99.9	84.1	420	5	M36 x 1.5	116	28

0205

BASE MOUNT UNITS WITH STANDARD HOLLOW SHAFT

UNIT SIZE & No OF REDUCTIONS		K0332	K0352	K0432	K0452	K0532	K0552	K0632	K0652	K0732	K0752	K0832	K0852	K0931	K0951	K1031	K1051	K1231	K1251	
REDUCER VERSION		16	24	21	29	32	43	40	51	61	70	113	139	174	197	306	321	458	485	
OUTPUT SHAFT		0.7	0.7	1.1	1.1	1.3	1.3	1.8	1.8	3.5	3.5	6.1	6.1	10.8	10.8	18.5	18.5	34.6	34.6	
OUTPUT FLANGE		1.3	1.3	2.8	2.8	4	4	5.4	5.4	7	7	15	15	17	17	26	26	26	26	
MOTORISED	63	Without Motor	16	25	21	30		44		52		70								
		With Motor	21	29	26	35		48		56		75								
		With Motor & Brake	22	30	27	36		49		57		76								
	71	Without Motor	16	24	21	30		44		52		70								
		With Motor	22	31	28	36		50		58		76								
		With Motor & Brake	23	32	29	37		51		59		77								
	80A	Without Motor	16	25	22	30	31	44	39	52	58	70	114	139	167	197		321		481
		With Motor	26	34	31	40	41	54	49	62	67	80	123	148	176	206		331		491
		With Motor & Brake	28	36	33	42	43	56	51	64	69	82	125	150	178	208		333		493
	80B	Without Motor	16	25	22	30	31	44	39	52	58	70	114	139	167	197		321		481
		With Motor	27	36	33	41	42	55	50	63	69	81	125	150	178	208		332		492
		With Motor & Brake	29	38	35	43	44	57	52	65	71	83	127	152	180	210		334		494
	90S	Without Motor	17	26	22	31	32	45	40	53	59	71	114	140	167	198		322		482
		With Motor	31	39	36	44	46	58	54	66	72	85	127	153	180	211		336		496
		With Motor & Brake	34	42	39	47	49	61	57	69	75	88	130	156	183	214		339		499
	90L	Without Motor	17	26	22	31	32	45	40	53	59	71	114	140	167	198		322		482
		With Motor	32	40	37	45	47	59	55	67	73	86	128	154	181	212		337		497
		With Motor & Brake	35	43	40	48	50	62	58	70	76	89	131	157	184	215		340		500
	90LA	Without Motor	17	26	22	31	32	45	40	53	59	71	114	140	167	198		322		482
		With Motor	37	46	42	51	52	65	60	73	79	91	134	160	187	218		342		502
		With Motor & Brake	39	48	44	53	54	67	62	75	81	93	136	162	189	220		344		504
	100L	Without Motor					35		43		61		116	142	169	200	293	325	427	485
		With Motor					59		67		85		140	166	193	224	317	349	451	509
		With Motor & Brake					64		72		90		145	171	198	229	322	354	456	514
112M	Without Motor					35		43		61		116	142	169	200	293	325	427	485	
	With Motor					66		74		92		147	173	200	231	324	356	458	516	
	With Motor & Brake					71		79		97		152	178	205	236	329	361	463	521	
112MA	Without Motor					35		43		61		116	142	169	200	293	325	427	485	
	With Motor					80		88		106		161	187	214	245	338	370	472	530	
	With Motor & Brake					85		93		111		166	192	219	250	343	375	477	535	
132SA	Without Motor									63		119		172		296	327	430	487	
	With Motor									111		167		220		344	375	478	535	
	With Motor & Brake									120		176		229		353	384	487	544	

ALL WEIGHTS IN KG ALL WEIGHTS EXCLUDE LUBRICANT AND ARE FOR STANDARD SHAFT MOUNT UNITS, FOR FLANGE OR BASE MOUNT UNITS ADD WEIGHT OF FLANGE / SHAFT (SHOWN AT TOP OF TABLE) TO THE FIGURES SHOWN ABOVE

0205

BASE MOUNT UNITS WITH STANDARD HOLLOW SHAFT

UNIT SIZE & No OF REDUCTIONS		K0332	K0352	K0432	K0452	K0532	K0552	K0632	K0652	K0732	K0752	K0832	K0852	K0931	K0951	K1031	K1051	K1231	K1251	
REDUCER VERSION		16	24	21	29	32	43	40	51	61	70	113	139	174	197	306	321	458	485	
OUTPUT SHAFT		0.7	0.7	1.1	1.1	1.3	1.3	1.8	1.8	3.5	3.5	6.1	6.1	10.8	10.8	18.5	18.5	34.6	34.6	
OUTPUT FLANGE		1.3	1.3	2.8	2.8	4	4	5.4	5.4	7	7	15	15	17	17	26	26	26	26	
MOTORISED	132M	Without Motor								63		119		172		296	327	430	487	
		With Motor								115		171		224		348	379	482	539	
		With Motor & Brake									124		180		233		357	388	491	548
	132MA	Without Motor									63		119		172		296	327	430	487
		With Motor									141		197		250		374	405	508	565
		With Motor & Brake									150		206		259		383	414	517	574
	132MB	Without Motor									63		119		172		296	327	430	487
		With Motor									151		207		260		384	415	518	575
		With Motor & Brake									160		216		269		393	424	527	584
	160MA	Without Motor											124		177		301		436	
		With Motor											205		258		382		517	
	160MB	Without Motor											124		177		301		436	
		With Motor											202		255		379		514	
	160L	Without Motor											124		177		301		436	
		With Motor											219		272		396		531	
	160M	Without Motor											124		177		301		436	
		With Motor											237		290		414		549	
	180M	Without Motor													190		314		448	
		With Motor													357		481		615	
	180L	Without Motor													190		314		448	
		With Motor													371		495		629	
	200L	Without Motor													194		318		453	
		With Motor													426		550		685	
	225S	Without Motor													198		322		457	
With Motor														485		609		744		
225M	Without Motor													198		322		457		
	With Motor													520		644		779		
250M	Without Motor																	471		
	With Motor																	856		
280S	Without Motor																	471		
	With Motor																	981		
280M	Without Motor																	471		
	With Motor																	1071		

ALL WEIGHTS IN KG ALL WEIGHTS EXCLUDE LUBRICANT AND ARE FOR STANDARD SHAFT MOUNT UNITS, FOR FLANGE OR BASE MOUNT UNITS ADD WEIGHT OF FLANGE / SHAFT (SHOWN AT TOP OF TABLE) TO THE FIGURES SHOWN ABOVE

IMPORTANT

Product Safety Information

General - The following information is important in ensuring safety. It **must** be brought to the attention of personnel involved in the selection of Textron Power Transmission equipment, those responsible for the design of the machinery in which it is to be incorporated and those involved in its installation, use and maintenance.

Textron Power Transmission equipment will operate safely provided it is selected, installed, used and maintained properly. As with any power transmission equipment **proper precautions must** be taken as indicated in the following paragraphs, to ensure safety.

Potential Hazards - these are **not** necessarily listed in any order of severity as the degree of danger varies in individual circumstances. It is important therefore that the list is studied in its entirety:-

- 1) Fire/Explosion
 - (a) Oil mists and vapour are generated within gear units. It is therefore dangerous to use naked lights in the proximity of gearbox openings, due to the risk of fire or explosion.
 - (b) In the event of fire or serious overheating (over 300 °C), certain materials (rubber, plastics, etc.) may decompose and produce fumes. Care should be taken to avoid exposure to the fumes, and the remains of burned or overheated plastic/rubber materials should be handled with rubber gloves.
- 2) Guards - Rotating shafts and couplings must be guarded to eliminate the possibility of physical contact or entanglement of clothing. It should be of rigid construction and firmly secured.
- 3) Noise - High speed gearboxes and gearbox driven machinery may produce noise levels which are damaging to the hearing with prolonged exposure. Ear defenders should be provided for personnel in these circumstances. Reference should be made to the Department of Employment Code of Practice for reducing exposure of employed persons to noise.
- 4) Lifting - Where provided (on larger units) only the lifting points or eyebolts must be used for lifting operations (see maintenance manual or general arrangement drawing for lifting point positions). Failure to use the lifting points provided may result in personal injury and/or damage to the product or surrounding equipment. Keep clear of raised equipment.
- 5) Lubricants and Lubrication
 - (a) Prolonged contact with lubricants can be detrimental to the skin. The manufacturer's instruction must be followed when handling lubricants.
 - (b) The lubrication status of the equipment must be checked before commissioning. Read and carry out all instructions on the lubricant plate and in the installation and maintenance literature. Heed all warning tags. Failure to do so could result in mechanical damage and in extreme cases risk of injury to personnel.
- 6) Electrical Equipment - Observe hazard warnings on electrical equipment and isolate power before working on the gearbox or associated equipment, in order to prevent the machinery being started.
- 7) Installation, Maintenance and Storage
 - (a) In the event that equipment is to be held in storage, for a period exceeding 6 months, prior to installation or commissioning, Textron Power Transmission must be consulted regarding special preservation requirements. Unless otherwise agreed, equipment must be stored in a building protected from extremes of temperature and humidity to prevent deterioration.
The rotating components (gears and shafts) must be turned a few revolutions once a month (to prevent bearings brinelling).
 - (b) External gearbox components may be supplied with preservative materials applied, in the form of a "waxed" tape overwrap or wax film preservative. Gloves should be worn when removing these materials. The former can be removed manually, the latter using white spirit as a solvent.

Preservatives applied to the internal parts of the gear units do not require removal prior to operation.
 - (c) Installation must be performed in accordance with the manufacturer's instructions and be undertaken by suitably qualified personnel.
 - (d) Before working on a gearbox or associated equipment, ensure that the load has been removed from the system to eliminate the possibility of any movement of the machinery and isolate power supply. Where necessary, provide mechanical means to ensure the machinery cannot move or rotate. Ensure removal of such devices after work is complete.
 - (e) Ensure the proper maintenance of gearboxes in operation. Use only the correct tools and Textron Power Transmission approved spare parts for repair and maintenance. Consult the Maintenance Manual before dismantling or performing maintenance work.
- 8) Hot Surfaces and Lubricants
 - (a) During operation, gear units may become sufficiently hot to cause skin burns. Care must be taken to avoid accidental contact.
 - (b) After extended running the lubricant in gear units and lubrication systems may reach temperatures sufficient to cause burns. Allow equipment to cool before servicing or performing adjustments.
- 9) Selection and Design
 - (a) Where gear units provide a backstop facility, ensure that back-up systems are provided if failure of the backstop device would endanger personnel or result in damage.
 - (b) The driving and driven equipment must be correctly selected to ensure that the complete machinery installation will perform satisfactorily, avoiding system critical speeds, system torsional vibration, etc.
 - (c) The equipment must not be operated in an environment or at speeds, powers, torques or with external loads beyond those for which it was designed.
 - (d) As improvements in design are being made continually the contents of this catalogue are not to be regarded as binding in detail, and drawings and capacities are subject to alterations without notice.

The above guidance is based on the current state of knowledge and our best assessment of the potential hazards in the operation of the gear units.

Any further information or clarification required may be obtained by contacting Textron Power Transmission.

Contact Textron Power Transmission

0105

AUSTRALIA

David Brown Gear Industries Ltd
13-19 Franklin Avenue
Bulli, NSW 2516
Australia
Tel: +61 2 4283 0300
Fax: +61 2 4283 0333

AUSTRIA

Benzler Antriebstechnik Ges mbH
Urnenhainweg 7
AT-4050 Traun
Austria
Tel: +43 7 229 618 91
Fax: +43 7 229 618 84

BELGIUM

Benzlers Belgium
Contact the Northern European Service Centre (Netherlands)
Tel: +32 25 82 59 22
Fax: +32 25 82 68 47

CANADA

David Brown Radicon Inc
975 Dillingham Road
Pickering, Ontario
L1W 3B2
Canada
Tel: +01 905 420 4141
Fax: +01 905 420 9513

DENMARK

Benzler Transmission A/S
Hammerholmen 39
DK-2650 Hvidovre
Denmark
Tel: +45 36 34 03 00
Fax: +45 36 77 02 42

FINLAND

Oy Benzler AB
PB 3
FI 02211 Espoo
Finland
Tel: +358 9 8870 630
Fax: +358 9 8870 631

FRANCE

Benzler France
Contact the Northern European Service Centre (Netherlands)
Tel: +33 130 32 79 00
Fax: +33 130 32 80 40

David Brown Transmissions France SA
42 Avenue du Progrès, BP 149
69686 Chassieu Cedex
France
Tel: +33 4 72 47 61 50
Fax: +33 4 72 47 61 69

DSN
9 rue de la Verrerie, BP 135
ZI Le Fontanil Cedex
38521 El Fontanil
France
Tel: +33 4 76 75 66 83
Fax: +33 4 76 75 57 99

WECO
33 Rue Henri-Lebert, BP 48
68801 Thann Cedex
France
Tel: +33 3 89 37 01 13
Fax: +33 3 89 37 39 36

GERMANY

Benzler Germany
Contact the Northern European Service Centre (Netherlands)
Tel: 0800 350 40 00
Fax: 0800 350 40 01

HUNGARY

Benzler Antriebstechnik Ges mbH
Urnenhainweg 7
AT-4050 Traun
Austria
Tel: +43 7 229 618 91
Fax: +43 7 229 618 84

ITALY

Benzler Ferri SpA
Via F.lli Rosselli 16
IT 42019 Scandiano (RE)
Italy
Tel: +39 05 22 763314
Fax: +39 05 22 981758

MALAYSIA

Benzler (M) Sdn Bhd
No 24 Jalan TPJ 3
Taman Perindustrian
Jaya Subang
MY 47200 Selangor
Malaysia
Tel: +60 3 745 0668
Fax: +60 3 746 1436

NETHERLANDS

Northern European Service Centre & HQ Benzlers Netherland
Postbox 3303
NL 5902 Venlo RH
Netherlands
Tel: +31 773 245 900
Fax: +31 773 245 901

NORWAY

Textron Power Transmission (Norge)
Incorporating Benzler A/S & David Brown Hydraulics Norway A/S
PO Box 73 Leirdal
Stromsveien 372
NO- 1008 Oslo
Norway
Tel: +47 22 90 94 30
Fax: +47 22 90 94 11

PHILIPPINES

David Brown John Welsh Custom Build (Pty) Ltd
Unit 1207 One Magnificent Mile
San Miguel Ave, Ortigas Centre
Pasig City, Philippines
Tel: +63 6 32 910 0316
Fax: +63 6 32 910 0317

SINGAPORE

Benzler (FE) Pte Ltd
1 Clementi Loop
#03-08
Singapore 129808
Tel: +65 469 0777
Fax: +65 469 2083

SOUTH AFRICA

David Brown Gear Industries Ltd
PO Box 540, Benoni 1500
South Africa
Tel: +27 11 748 0000
Fax: +27 11 421 2963

David Brown Gear Industries Ltd
PO Box 36882
Chempet 7442
Cape Town
South Africa
Tel: +27 21 551 2163
Fax: +27 21 551 2164

David Brown Gear Industries Ltd
Natal Sales Office
39 Richmond Road
Pinetown 3600
Natal, South Africa
Tel: +27 31 700 3302
Fax: +27 31 700 1872

SWEDEN

AB Benzlers
PO Box 922
SE-251 09 Helsingborg
Sweden
Tel: +46 42 18 6800
Fax: +46 42 21 8803

THAILAND

David Brown Powauto (Thailand) Ltd
Level 5 Sermsrap Building
169/98 Ratchadapisek Road
Din Daeng, Bangkok 10320
Thailand
Tel: +66 2 276 9504/5/6
Fax: +66 2 276 9503

UNITED KINGDOM

Textron Power Transmission Corporate HQ
Park Road
Lockwood, Huddersfield
West Yorkshire. HD4 5DD
Tel: +44 (0) 1484 465500
Fax: +44 (0) 1484 465501

David Brown Engineering Ltd
Park Road
Lockwood, Huddersfield
West Yorkshire. HD4 5DD
Sales
Tel: 0800 970 4001
Fax: 0800 970 4002
Service & Spare Parts
Tel: 0800 970 4003
Fax: 0800 970 4004

USA

Cone Drive Textron
240 East 12th Street
Traverse City
MI 49684
USA
Tel: +01 231 946 8410
Fax: +01 231 933 8600

David Brown Radicon
2040 Carboy Road
Mt Prospect
Illinois 60056
USA
Tel: +01 847 290 7500
Fax: +01 847 290 6510

AGRICULTURE

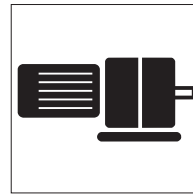

Geared motors

AUTOMOTIVE

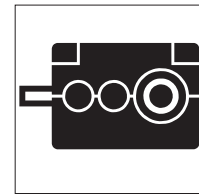

Industrial reducers

CEMENT

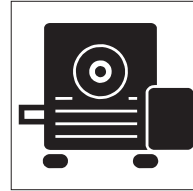

Worm

CHEMICAL

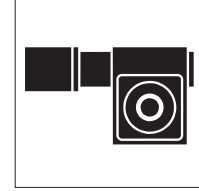

Precision products

CONSTRUCTION

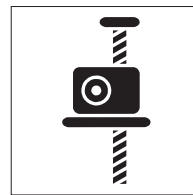

Screwjacks

DEFENCE

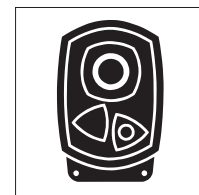

Shaftmount

ENERGY

FOOD & BEVERAGE

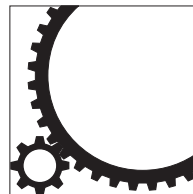

Horizontal mill drives

FORESTRY

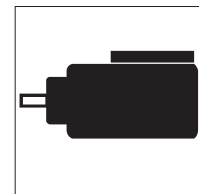

Vertical mill drives

MARINE

METALS

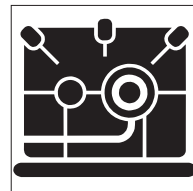

High speed

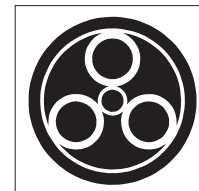

Planetary units

MINING

PULP & PAPER

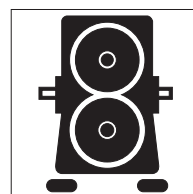

Specialist drives

QUARRYING

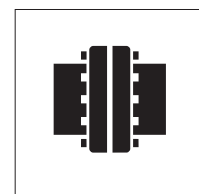

Couplings

RUBBER & PLASTICS

TEXTILES



Defence Systems

TRANSPORTATION

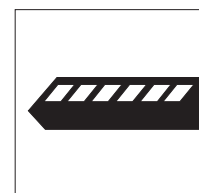

Rail

WATER

TEXTRON POWER TRANSMISSION

www.TextronPT.com